





Installation Guide **Noise Isolation Feet**

Document Version 3.0
November 24, 2025

Revision History

Document Revision Number	Description	Date
3.0	Removed <ul style="list-style-type: none">Xoi workflow step Replaced <ul style="list-style-type: none">Turntide Academy link with support.turntide.com	November 24, 2025
2.1	Correct images for KIT-ISLN-FT-301 – feet are symmetrical and therefore do NOT have indicate lines. See	March 1, 2023
2.0	New format Includes the following new content: <ul style="list-style-type: none">SKU informationTorque settingsNew images and diagramsAdditional tool recommendationsMore information on installing motor on vertical mounting plate, narrow mounting plate will filler blocksTroubleshooting a stalled motor because of belt tension	February 21, 2023

Conventions

Bold	<ul style="list-style-type: none"> • Used in procedures for names of interface elements, such as buttons, fields, and menu items. • For names of apps. • For emphasis, typically when introducing a new concept or for the adverb “not.” • For measurements when necessary to distinguish from surrounding text
<i>Italics</i>	References for names of additional Turntide guides and documents.
Links	Blue font for cross-references within document and to external sources.
Note:	Indicates information that can help a customer make better use of a Turntide product.
Caution icon 	Indicates an instruction that draws attention to the risk of damage to the product, process, or surroundings.
Warning icon 	Indicates an instruction that draws attention to risk of injury or death and tells the customer how to avoid the potential problem.

Legal

The information in this document is subject to change without notice and should not be construed as a commitment by Turntide Technologies® or Software Motor Company. Turntide Technologies assumes no responsibility for any errors that may appear in this document. In no event shall Turntide Technologies be liable for incidental or consequential damages arising from use of this document or the software and hardware described in this document. © Turntide Technologies. All rights reserved.

Contact

support@turntide.com | 11720 Amber Park Drive, Suite 160, Alpharetta, GA 30009 | www.turntide.com

Contents

Audience	4
Resources	4
Front Views of Noise Isolation Feet Installed	5
Motor Noise Isolation Kit and Corresponding SKU	6
Tools You'll Need	7
Preliminary Task: Remove the existing motor	8
KIT-ISLN-FT-101 Motor Noise Isolation Feet Installation on V01 and V02 Motors, Frames A, C, and D	10
KIT-ISLN-FT-201 Motor Noise Isolation Feet Installation on V01 and V02 Motors, Frame F	14
KIT-ISLN-FT-301 Motor Noise Isolation Feet Installation on V03 Motors, Frame H	17
Re-install motor and mounting plate assembly in RTU	20
Special Instructions for Installation on a Vertical Mounting Plate	24
Key Concepts	24
Appendix	29
Troubleshooting a Stalled Motor	29

Audience

The instructions in this guide are intended for a mechanical technician who is familiar working with commercial HVAC systems such as rooftop units (RTUs), air handling units (AHUs), and other similar equipment.

You will have access to Support from Turntide Technical Services: <https://support.turntide.com/>



Required: Follow all local and national electrical codes, safety compliance requirements, and common installation procedures.

Resources

Additional resources, such as data sheets, wiring diagrams, installation guides, training resources, and much more are available at <https://support.turntide.com/>.

Front Views of Noise Isolation Feet Installed

V01 motor with noise isolation feet KIT-ISLN-FT-101 installed

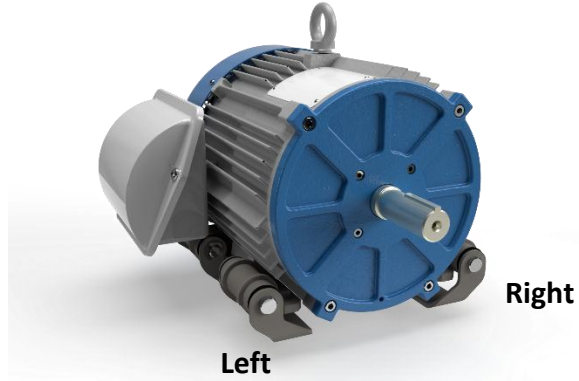

V02 motor with noise isolation feet KIT-ISLN-FT-201 installed

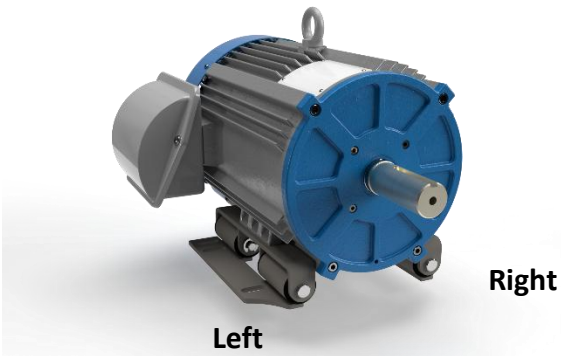

V03 motor with noise isolation feet KIT-ISLN-FT-301 installed

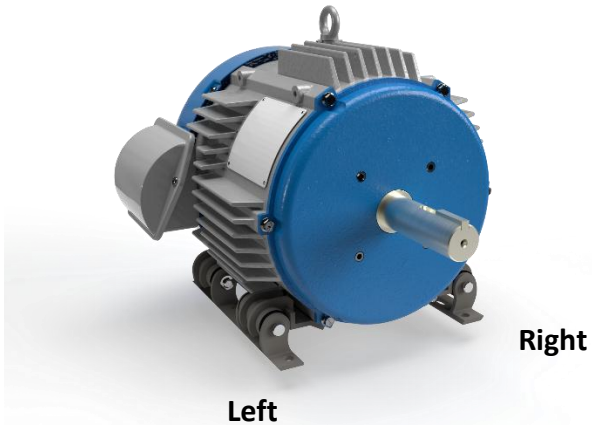

Motor Noise Isolation Kit and Corresponding SKU

Table 1 Kit & Motor and Frame SKU Match









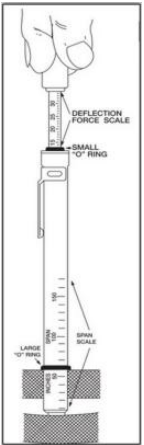

KIT	SKU (motor and frame)	Notes
KIT-ISLN-FT-101	V01-0300-2-A00 V01-0300-4-A00 V01-0300-2-C00 V01-0300-4-C00 V01-0300-6-C00 V01-0300-2-D00 V01-0300-4-D00 V01-0300-6-D00 V02-0500-2-D00 V02-0500-4-D00 V02-0500-6-D00	Frames are A, C, D V02 motors with a 143/145T frame size require KIT_ISLN-FT-101.
KIT-ISLN-FT-201	V01-0300-2-F00 V01-0300-4-F00 V01-0300-6-F00 V02-0500-2-F00 V02-0500-4-F00 V02-0500-6-F00	Frame F V01-F motors, which are less than 3hp motors with a 182/184T frame size require KIT-ISLN-FT-201.
KIT-ISLN-FT-301	V03-1500-4-H00 V03-1500-6-H00	Frame H

Table 2 Torque required for Nylon-Patch Thread-Locking Fasteners

Kit	Fastener	Torque Inch Pounds	Torque Foot Pounds	Torque Nm
KIT-ISLN-FT-101	Two M6 x 1mm x 16mm Nylon-Patch Thread-Locking Fasteners	170.0 in-lbs ± 11.2 in-lbs	14 ft-lbs ± 1 ft-lbs	19.2 Nm ± 1.3 Nm
KIT-ISLN-FT-201	Four M6 x 1mm x 16mm Nylon-Patch Thread-Locking Fasteners	170.0 in-lbs ± 11.2 in-lbs	14 ft-lbs ± 1 ft-lbs	19.2 Nm ± 1.3 Nm
KIT-ISLN-FT-301	Eight M6 x 1mm x 16mm Nylon-Patch Thread-Locking Fasteners	170.0 in-lbs ± 11.2 in-lbs	14 ft-lbs ± 1 ft-lbs	19.2 Nm ± 1.3 Nm
	Eight M8 x 1.25mm x 16mm Nylon-Patch Thread-Locking Fasteners	330.0 in-lbs ± 19.5 in-lbs	27.5 ft-lbs ± 1.6 ft-lbs	37.3 Nm ± 2.2 Nm

Tools You'll Need

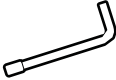
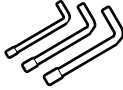
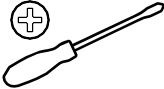
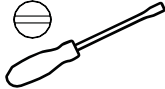
Table 3 Tools

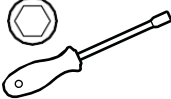
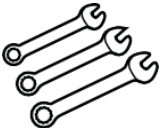
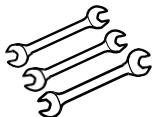
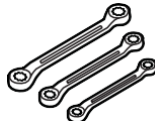
 <p>Belt tension gauge</p>	 <p>M5 Hex bit socket (for torque wrench) M6 Hex bit socket (for torque wrench)</p>	 <p>Torque wrench 5 to 50 N-m 44 1/4 to 442 1/2-inch pounds</p>	 <p>Cordless drill Measuring tape</p>
 <p>5/16" x 1" Carriage bolt Qty - 1 5/16" Push Nut Bolt Retainer Qty - 2</p> <p>Vertical Mounting Plate Installation Only</p>		 <p>Blower/Fan Pulley Motor Sheave/Pulley Straight edge</p> <p>Straight edge for pulley alignment</p>	
 <p>Adjustable pliers</p>	 <p>Needle nose pliers</p>	 <p>Hex wrenches 5mm and 6mm (for M6/M8 socket head cap screws)</p>	 <p>Hex metric wrenches (for socket head cap screws)</p>
 <p>Screwdriver Phillips</p>	 <p>Screwdriver slot</p>	 <p>Screwdriver, small terminating</p>	 <p>Nut driver 1/4in and 5/16in</p>
 <p>Combo Box/Open-End wrenches up to 3/4in Ratcheting type recommended.</p>	 <p>Thin head access wrenches</p>	 <p>90-degree offset wrenches</p>	

Preliminary Task: Remove the existing motor

For any kit, complete the following steps to remove the existing Turntide motor and mounting plate assembly from the RTU:

<p>1</p>	<p>Isolate all incoming power to HVAC unit using normal Lock Out/Tag Out protocol and local code requirements. Verify no power is present at the unit.</p> <div data-bbox="636 445 1019 606" data-label="Image"> </div>
<p>2</p>	<p>Identify the Turntide motor and frame size using the codes found on the nameplate. <i>In the example image, the motor is V01, Frame A.</i></p> <div data-bbox="462 716 1198 1276" data-label="Image"> </div>
<p>3</p>	<p>Confirm that you have the correct noise isolation feet for your motor and frame before continuing. See Table 1 Kit & Motor and Frame SKU Match.</p>

4 Unbolt the mounting plate from the RTU.

Remove the Turntide motor *along with the mounting plate*. If necessary, disconnect the motor power wires.

Tip: Before removing the motor-mounting plate assembly, measure and **record the distance** between the end of the motor mounting plate and the end of motor pulley.

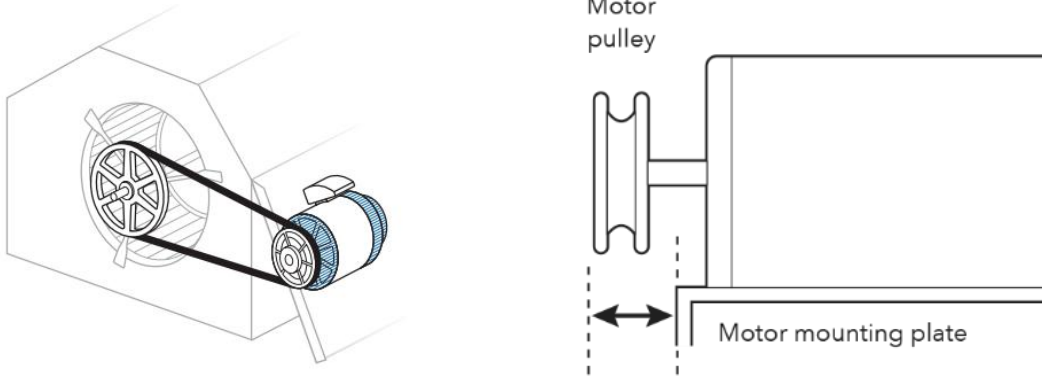

5 After you have removed the existing Turntide motor and mounting plate assembly from the RTU, go to the instructions for **your specific noise isolation feet kit:**

[KIT-ISLN-FT-101 Motor Noise Isolation Feet Installation on V01 and V02 Motors, Frames A, C, and D](#)

[KIT-ISLN-FT-201 Motor Noise Isolation Feet Installation on V01 and V02 Motors, Frame F](#)

[KIT-ISLN-FT-301 Motor Noise Isolation Feet Installation on V03 Motors, Frame H](#)

Important: Do **NOT** use feet spacers or bolt sleeves with noise isolation feet.

KIT-ISLN-FT-101 Motor Noise Isolation Feet Installation on V01 and V02 Motors, Frames A, C, and D

Important:

- Assumes you have removed the existing mounting plate along with the motor from the RTU.
- Do **NOT** use feet spacers or bolt sleeves with noise isolation feet.

- 1** 1. Remove the motor from the mounting plate. Units with larger horsepower motors will have a more substantial mounting plate than the image provided in this step.



2. Using a 5mm hex wrench, remove the bolts, lock washers, and **existing motor feet** from the motor.

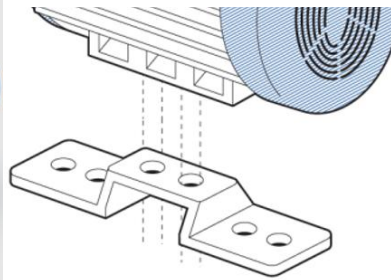
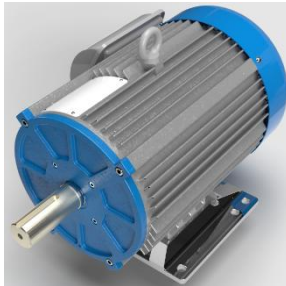

3. Remove foot spacers and mounting plate sleeves if they were installed, as they increase shaft height.



2 Examine the new noise isolation feet:

- The feet in KIT-ISLN-FT-101 are **not** symmetrical. They are identified as *Left* and *Right*, when facing the shaft end of the motor.
- The shorter barrel faces toward the motor shaft end. (A sticker indicates the direction.)
- Color indicator lines on the isolation foot upper and lower sections indicate which pieces go together when reassembling the isolation foot.
- The left foot is marked **yellow** the right foot is marked **white**.

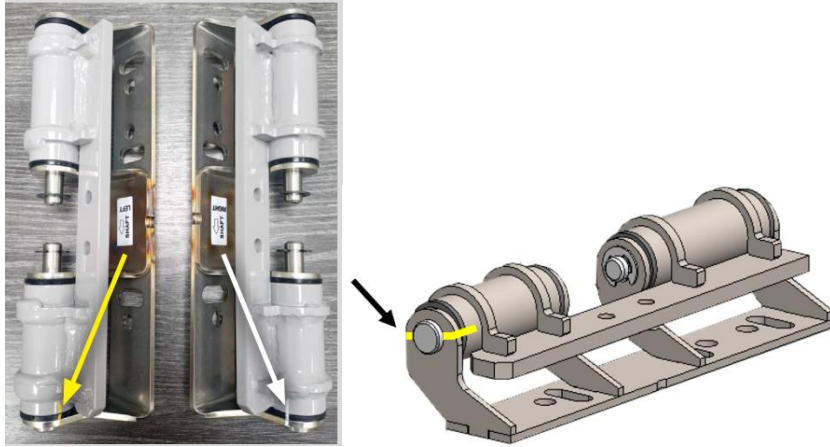

3 Disassemble the noise isolation feet to allow for easier installation:

Remove the E-clips from the clevis pins, sliding clevis pins out, to separate the lower foot section from the upper foot section.

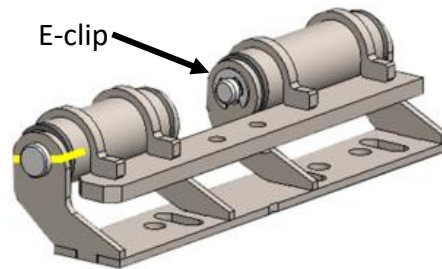

- 4 Install the **lower section** of the Left and Right noise isolation feet **to the mounting plate** BUT do **not** tighten the bolts yet! The Left foot is marked **yellow**, and the Right foot is marked **white**.

The position of the motor (and therefore noise isolation feet) relative to the mounting plate is determined based on where the pulley/belt is on the blower fan as well.

Lower section of foot installed on the mounting plate.

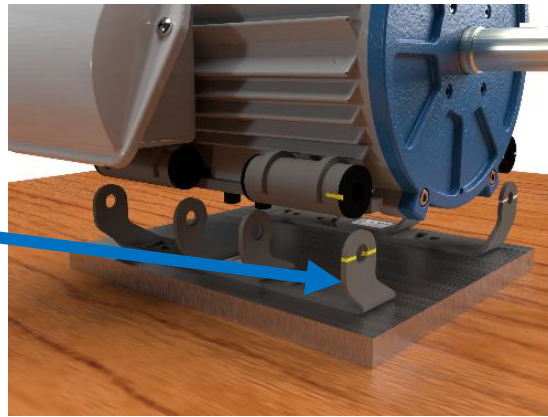

Special Cases:

Narrow Mounting Plate: If you are using a narrow mounting plate with a V01 motor and KIT-ISLN-FT-101, you will need filler blocks to allow the feet to hang over the edge of the mounting plate.

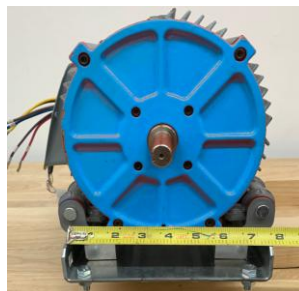
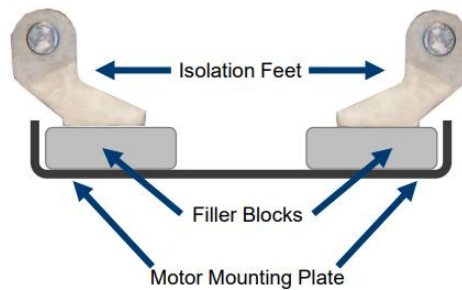

Vertical Mounting Plate: If your mounting plate is positioned vertically, at this point, follow instructions in [Special Instructions for Installation on a Vertical Mounting Plate](#) before proceeding with Step 5.

- 5**
1. Install the upper section of the Left and Right noise isolation feet **to the motor**.
 2. Ensure that bolts connecting motor isolation feet to the motor body are torqued to specifications:
The noise isolation feet in KIT-ISLN-FT-101 for motors V01 and V02 (A, C, and D frames) includes two **M6 x 1mm x 16 mm fasteners**. See correct torque value in [Table 2 Torque required for Nylon-Patch Thread-Locking Fasteners](#).

Upper section of foot installed on the motor.

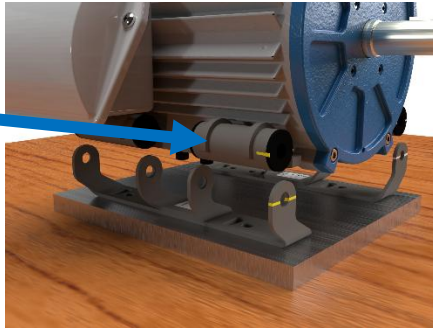

- 6**
1. Reconnect the upper and lower sections of the noise isolation feet using the clevis pins and E-clips.
 2. Carefully align the motor on the mounting plate on a flat surface.
 3. Fully tighten the lower noise isolation feet bolts.

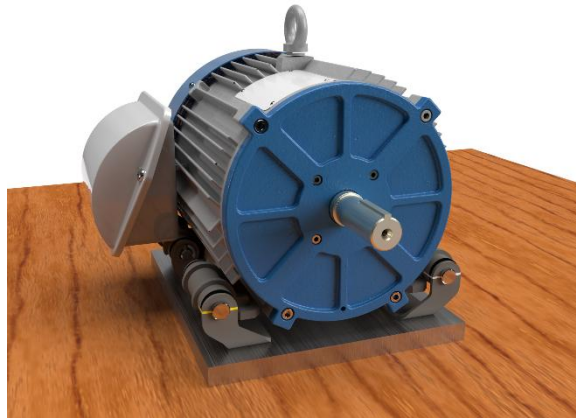

7 Go to: [Re-install motor and mounting plate assembly in RTU.](#)

KIT-ISLN-FT-201 Motor Noise Isolation Feet Installation on V01 and V02 Motors, Frame F

Important:

- Assumes you have removed the existing mounting plate along with the motor from the RTU.
- Do **NOT** use feet spacers or bolt sleeves with noise isolation feet.

- 1** 1. Remove the motor from the mounting plate. Units with larger horsepower motors will have a more substantial mounting plate than the image provided in this step.



2. Using a 5mm hex wrench, remove the bolts, lock washers, and **existing motor feet** from the motor.
3. Remove feet spacers and mounting plate sleeves if they were installed, as they increase shaft height.

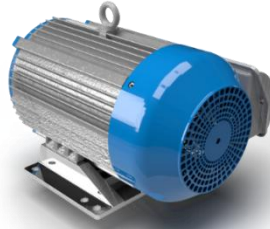

2 Examine the new noise isolation feet:

- The feet in KIT-ISLN-FT-201 are **NOT symmetrical**. They are identified as Left and Right, when facing the shaft end of the motor.
- Color indicator lines on the isolation foot upper and lower sections indicate which pieces go together when reassembling the isolation foot. The left foot is marked **yellow** the right foot is marked **white**.

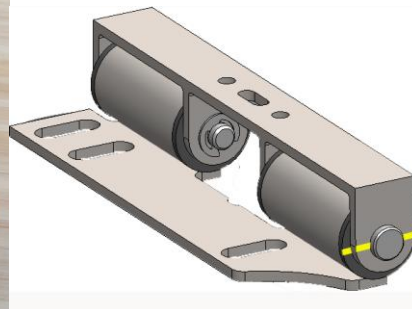

- 3 Disassemble the noise isolation feet:**
Remove the E-clips from the clevis pins, sliding clevis pins out, to separate the lower foot section from the upper foot section.

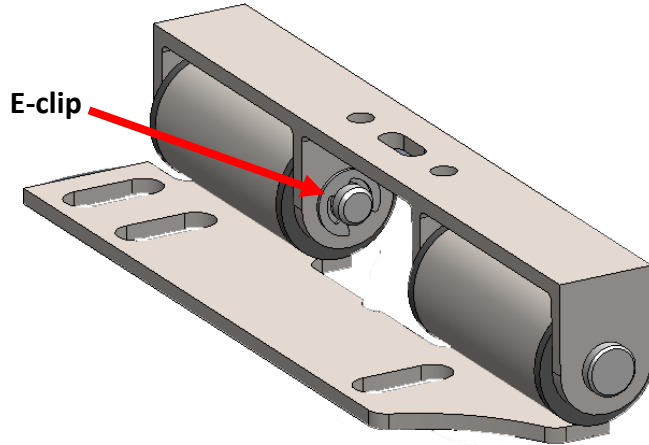

- 4 Install the lower section of the Left and Right noise isolation feet to the mounting plate BUT do NOT tighten the bolts yet!** The Left foot is marked **yellow** the Right foot is marked **white**.

The position of the motor (and therefore noise isolation feet) relative to the mounting plate is determined based on where the pulley/belt is on the blower fan as well.

Lower section of foot installed on the mounting plate

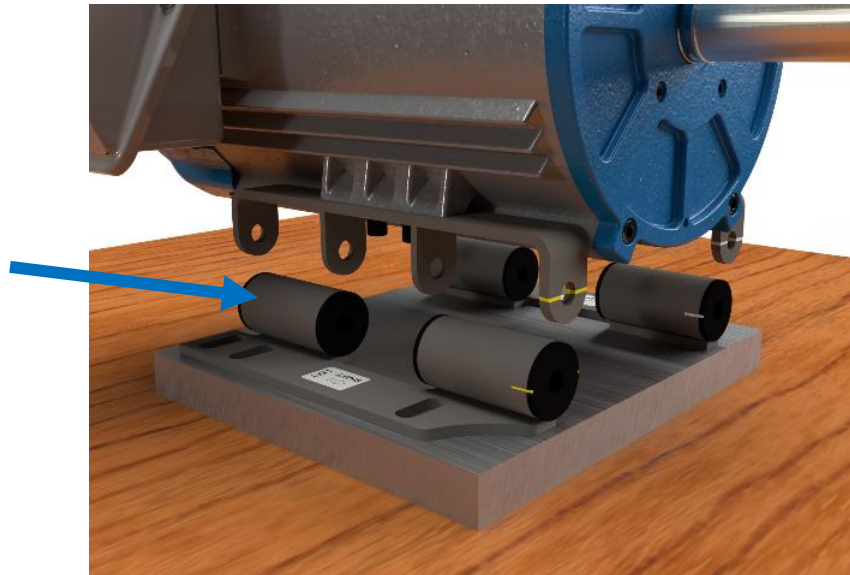

- 5**
1. Install **the upper section** of the Left and Right noise isolation feet **to the motor**.
 2. Ensure that bolts connecting motor isolation feet to the motor body are correctly torqued to specifications for the (4x) M6 x 1mm x 16mm Nylon-Patch Thread-Locking fasteners. See correct torque value in [Table 2 Torque required for Nylon-Patch Thread-Locking Fasteners](#).

Upper section of foot installed on the motor.

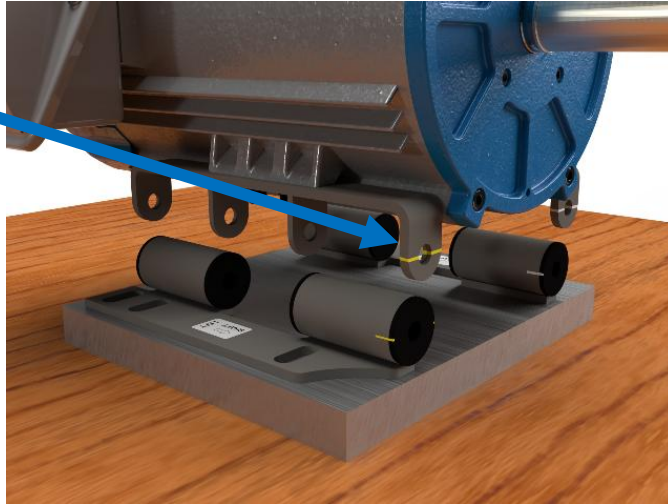

- 6**
1. Reconnect the upper and lower sections of the noise isolation feet using the clevis pins and E-clips.
 2. Carefully align the motor on the mounting plate on a flat surface.
 3. Fully tighten the lower noise isolation feet bolts to the mounting plate.

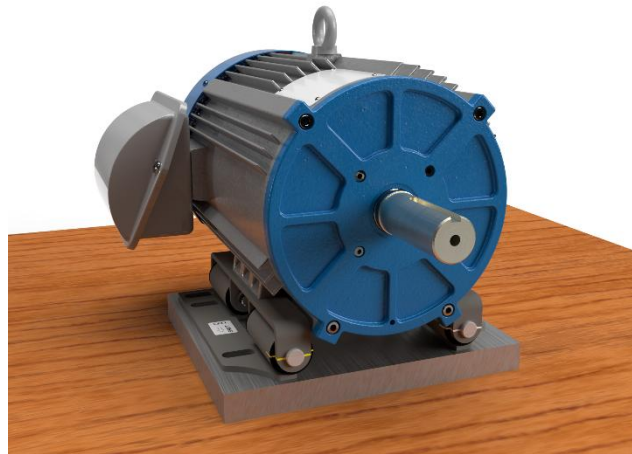

- 7** **Go to:** Re-install motor and mounting plate assembly in RTU [Re-install motor and mounting plate assembly in RTU](#).

KIT-ISLN-FT-301 Motor Noise Isolation Feet Installation on V03 Motors, Frame H

Important:

- Assumes you have removed the existing mounting plate along with the motor from the RTU.
- Do **NOT** use feet spacers or bolt sleeves with noise isolation feet

- 1** 1. Remove the motor from the mounting plate. Units with larger horsepower motors will have a more substantial mounting plate than the image provided in this step.



2. Using hex wrench, remove the bolts, lock washers, and **existing motor feet** from the motor.
3. Remove feet spacers and mounting plate sleeves if they were installed, as they increase shaft height

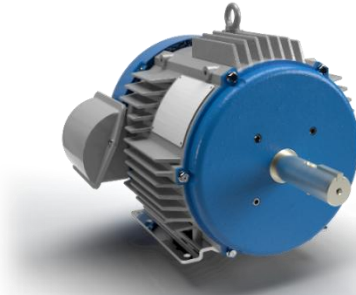

- 2** **Examine the new noise isolation feet:**
The feet in KIT-ISLN-FT-301 are **symmetrical**.



3 Disassemble the noise isolation feet:

Remove the E-clips from the clevis pins, sliding clevis pins out, to separate the lower foot section from the upper foot section.

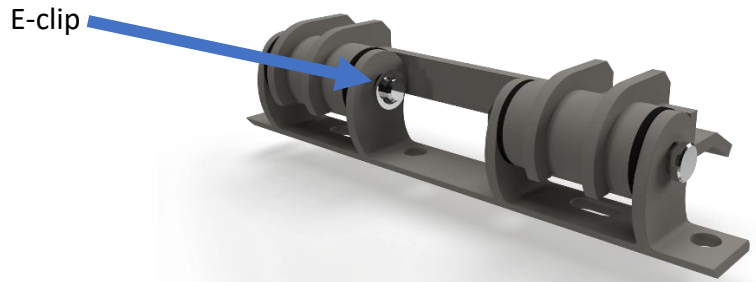

4 Install the lower section of the Left and Right noise isolation feet to the mounting plate BUT do NOT tighten the bolts yet!

The position of the motor (and therefore noise isolation feet) relative to the mounting plate is determined based on where the pulley/belt is on the blower fan as well.

Lower section of foot installed on the mounting plate

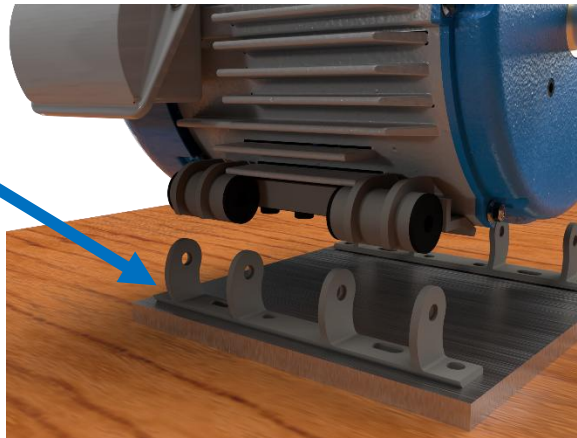

- 5**
1. Install the upper section of the noise isolation feet **to the motor**.
 2. Ensure that bolts connecting motor isolation feet to the motor body are torqued to specifications. Depending on the housing of your V03 motor, you will use the M6 or M8 fasteners. **KIT-ISLN-FT-301** Motor Noise Isolation Feet Installation on V03 Motors, Frame H includes:
 - Eight M6 x 1mm x 16mm Nylon-Patch Thread-Locking Fasteners
 - Eight M8 x 1.25mm x 16mm Nylon-Patch Thread-Locking Fasteners
 See correct torque values in [Table 2 Torque required for Nylon-Patch Thread-Locking Fasteners](#).

Upper section of foot installed on the motor.

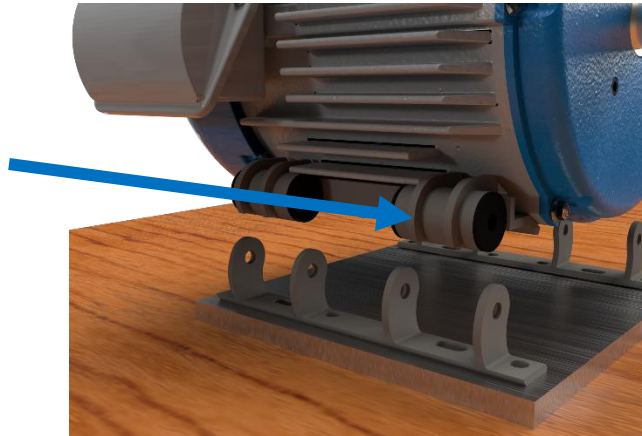

- 6**
1. Reconnect the upper and lower sections of the noise isolation feet using the clevis pins and E-clips.
 2. Carefully align the motor on the mounting plate on a flat surface.
 3. Fully tighten the lower noise isolation feet bolts.

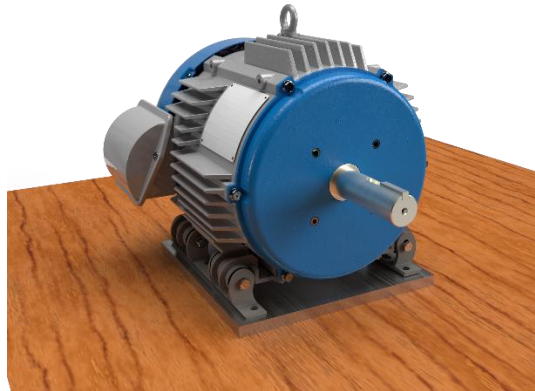

7 **Go to: [Re-install motor and mounting plate assembly in RTU.](#)**

Re-install motor and mounting plate assembly in RTU

- 1 Reinstall the motor and mounting plate assembly in the RTU.

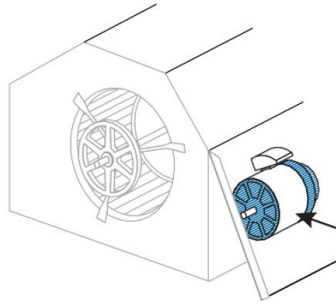

- 2

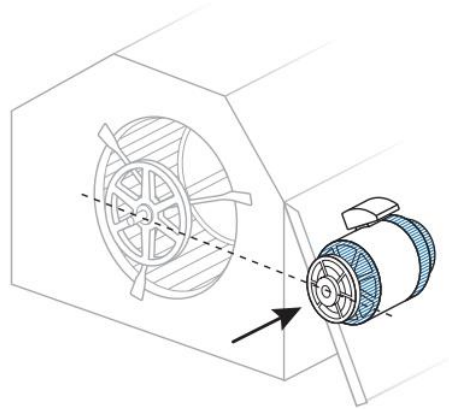

Reinstall original motor pulley. If the existing pulley shows signs of excessive wear, it should be replaced. Replacing worn components will ensure that the system is running most efficiently.

Fan Pulley and Motor Pulley Alignment

1. For proper belt seating, ensure the centerline of the pulleys are aligned. Use a straight edge to verify pulley alignment.
2. Verify that all pulley setscrews are secure.



3 Install the belt



Caution: To properly follow these instructions, you will need a belt tensioning tool that utilizes a spring depressor that reads in pounds and fractions of an inch. **Do not attempt to tension the belt without the proper testing tools.** Failure to properly tension the belt may cause bearing failure or permanent damage to the motor.

Belts will loosen after running and warming up. Final adjustments should be made after 10 minutes of run time. If the existing belt shows signs of excessive wear, it should be replaced.

1. Measure the distance (inches) from the center shaft of the motor to the center shaft of the blower wheel.

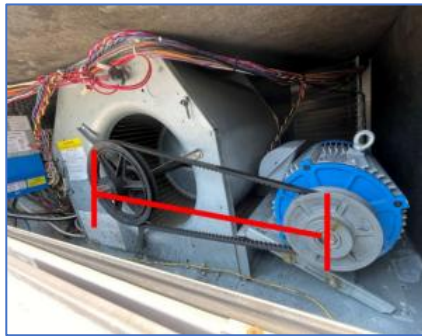

2. Round the distance to the closest value. If evenly divided, round down. *For example, 20 1/2 inches in round down to 20 inches.*
3. Set the bottom O-ring of the belt tension gauge to that value. *For example, slide the O-ring down to the 20-inch mark or notch on your gauge.*

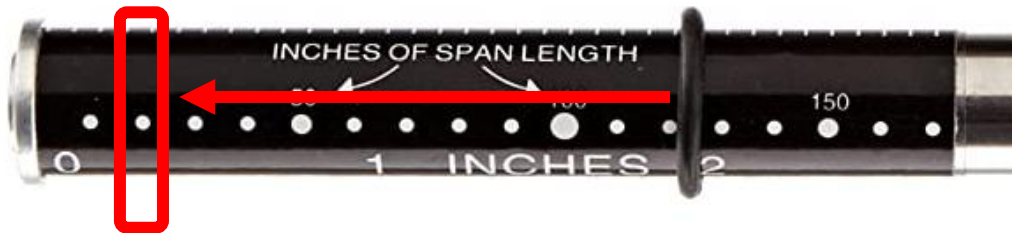

4. Set the top O-ring at zero (0). (Slide the O-ring to the base.)



5. Set a straight edge across the top of the belt. Deflect the belt until the bottom **O-ring** is in the same plane as the straight edge.

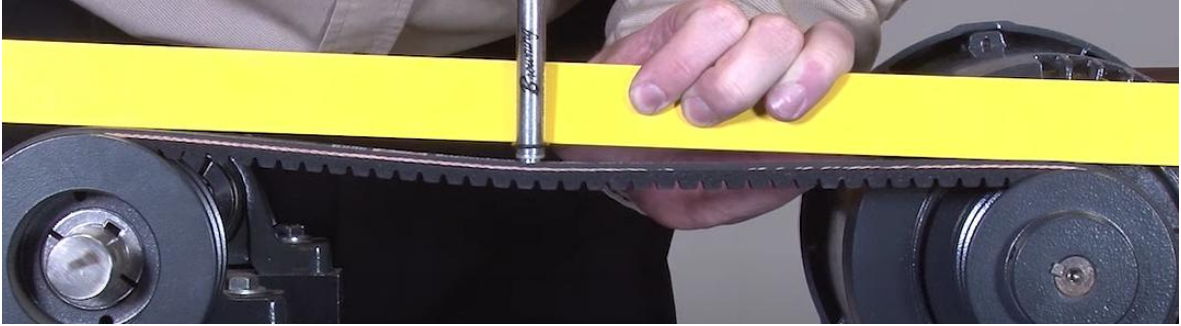

HVAC industry standard

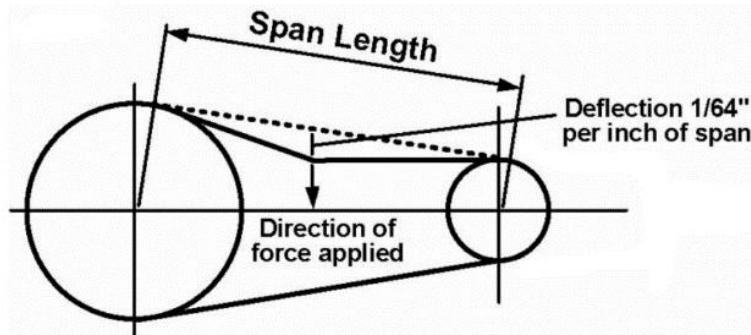

6. The top O-ring will have moved up the gauge and show the amount of force used. For example, say 7 pounds.
7. Measure the (outside) diameter of the smaller pulley. *The diameter of the smaller pulley determines pressure to the belt that should be applied to the belt.*



8. Using a deflective force chart, find the value your tension gauge registered and compare it with the diameter of the smaller pulley.

For example, if you are using a BX type belt, your tension gauge registered 10 pounds of force, and the smaller pulley is 5 inches in diameter, then the belt is tension is in the acceptable range.

	Smallest Pulley Diameter Range	RPM Range	Belt Deflection Setting			
			uncogged belts		cogged belts	
			used belt	new belt	used belt	new belt
4L, A, AX	2.0 - 2.9	1000 - 2500	1.8	2.6	2.0	3.0
		2501 - 4000	1.4	2.0	1.6	2.4
	3.0 - 3.6	1000 - 2500	3.6	5.4	4.0	6.0
		2501 - 4000	2.8	4.1	3.3	4.9
	3.8 - 4.8	1000 - 2500	4.4	6.6	4.9	7.3
		2501 - 4000	3.7	5.7	4.3	6.4
5.0 - 7.0	1000 - 2500	5.3	7.8	5.7	9.2	
	2501 - 4000	4.6	6.8	5.1	7.6	
	3.4 - 4.2	860 - 2500			4.8	7.2
		2501 - 4000			4.1	6.2
5L, B, BX	4.4 - 5.6	860 - 2500	5.2	7.9	7.1	10.5
		2501 - 4000	4.5	6.6	7.1	9.1
	5.8 - 8.6	860 - 2500	6.2	9.4	8.4	12.4
		2501 - 4000	6.0	6.8	7.3	10.7

If the belt cannot be properly tensioned, install a longer or shorter belt, as necessary.

- 4 Restore power and verify motor and unit operation.

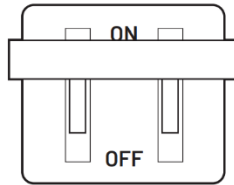

- 5 Reinstall the RTU panels. Ensure that all unit disconnects are in the ON position.

Special Instructions for Installation on a Vertical Mounting Plate

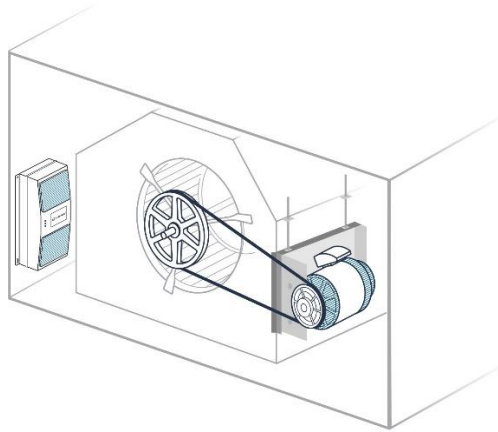

Key Concepts

BEFORE:

In an existing vertical mounting plate installation, the bolts are positioned with the thread facing the motor. As you can see in the example image, the bolt extends towards the motor.

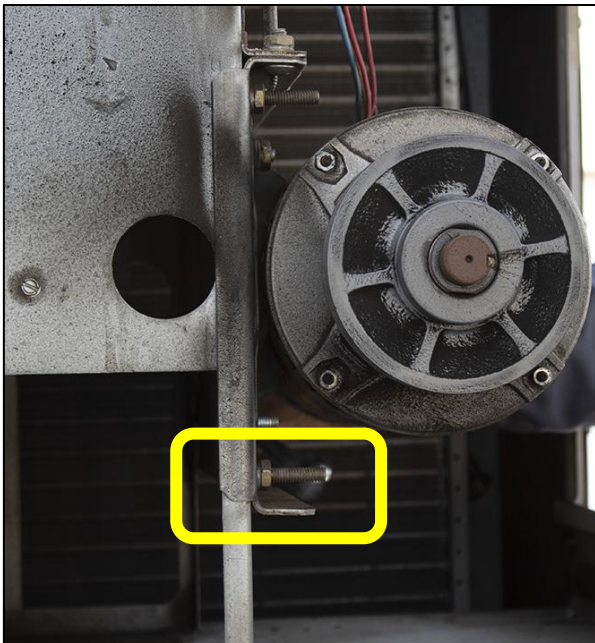

AFTER:

You will be reversing the mounting bolts (180 degrees) with the noise isolation feet installation. As you can see in the example image, the bolt thread now extends **towards** the RTU. This allows you to access the nut when belt tension adjustment is necessary.

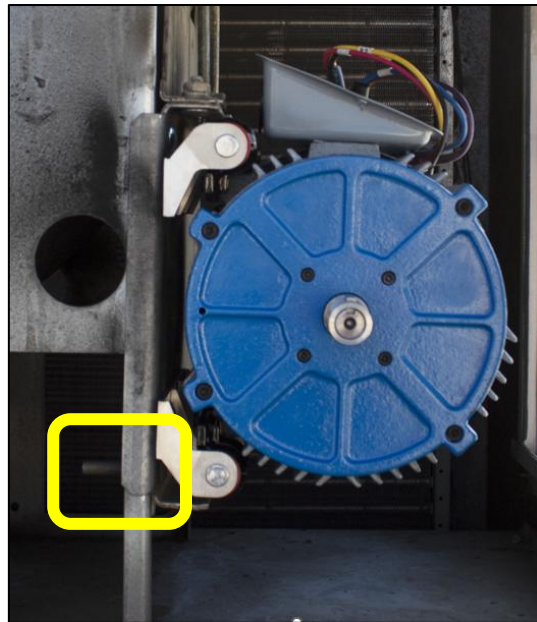

In your *existing* Turntide motor installation, the carriage bolts may have sleeves.

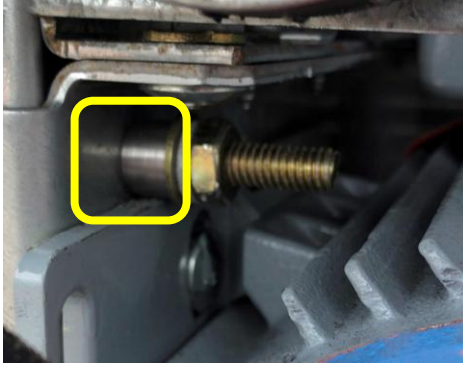

You will **not** use sleeves with the installation of the noise isolation feet.

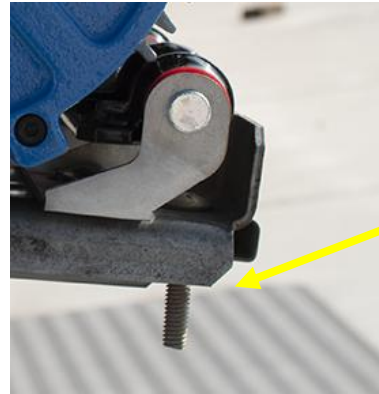

Before you begin, note the following:

1. Assumes you have removed the existing mounting plate.
2. **Important:** Feet spacers, bolt sleeves, and filler blocks are **not** applicable to this configuration.
3. You will reuse all the existing mounting bolts but turn all the bolts 180 degrees.
4. In the upper left corner of the mounting plate, use a **5/16in x 1in** carriage bolt. Using a shorter bolt ensures that it will **NOT** protrude into the blower housing.
5. You might have to shift the entire assembly down to get a good fit. This is necessary if the blower housing is preventing ample space for nut installation on the bolt in the upper right corner and proper bolt seating.

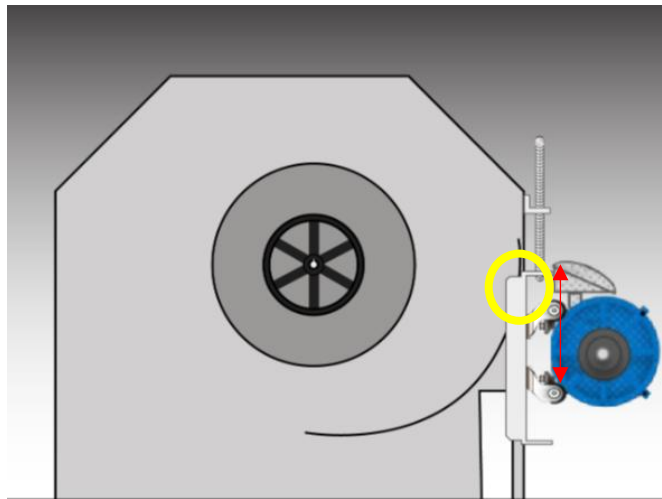

1. Install the **5/16in x 1in** carriage bolt in the upper left corner of the **top** of mounting plate.
2. Install the remaining bolts and add push nut bolt retainer to the bolts nearest the shaft/belt.

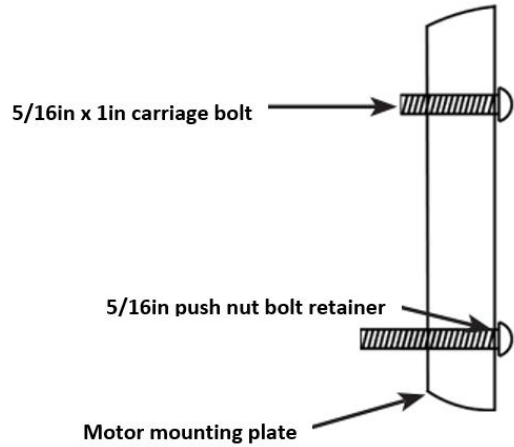
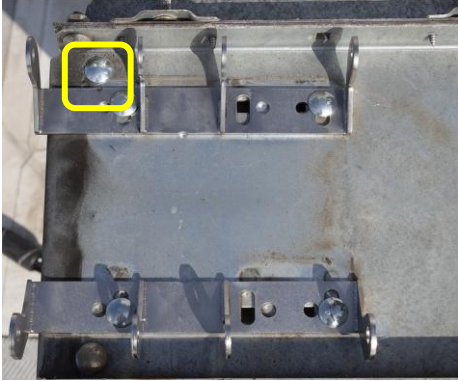

2. Install the **lower section** of the Left and Right noise isolation feet **to the mounting plate** BUT do **not** tighten the bolts yet! The Left foot is marked **yellow**, and the Right foot is marked **white**.

The position of the motor (and therefore noise isolation feet) relative to the mounting plate is determined based on where the pulley/belt is on the blower fan as well.

Lower section of foot installed on the mounting plate.

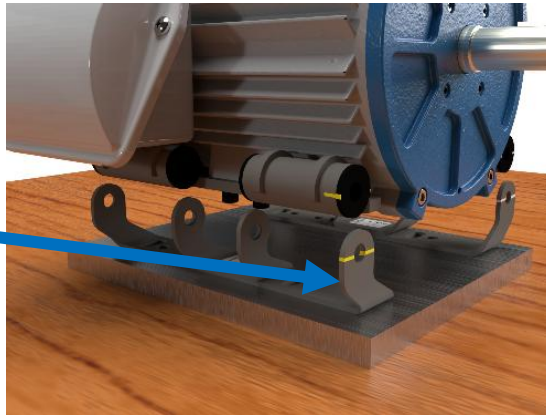

- 3**
1. Install the upper section of the Left and Right noise isolation feet **to the motor**.
 2. Ensure that bolts connecting motor isolation feet to the motor body are torqued to specifications.
KIT-ISLN-FT-101 for motors V01 and V02 (A, C, and D frames) includes: Two M6 x 1mm x 16mm Nylon-Patch Thread-Locking Fasteners. See correct torque values in [Table 2 Torque required for Nylon-Patch Thread-Locking Fasteners](#).

Upper section of foot installed on the motor.

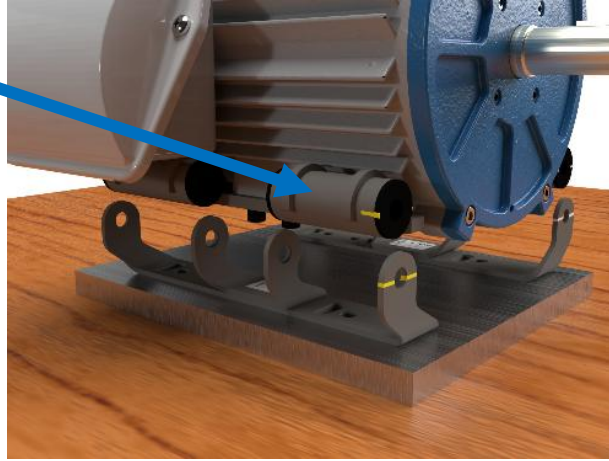

- 4**
1. Reconnect the upper and lower sections of the noise isolation feet using the clevis pins and E-clips.
 2. Carefully align the motor on the mounting plate on a flat surface.
 3. Fully tighten the lower noise isolation feet bolts.



5 Reinstall the motor and mounting plate assembly in the RTU.

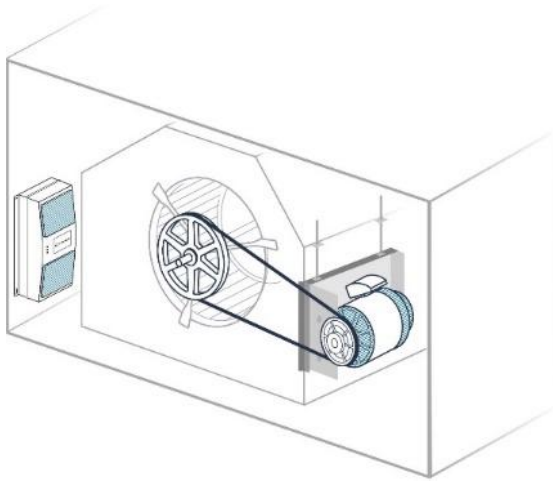

Appendix

Troubleshooting a Stalled Motor

Included in this guide because you will be removing the belt during installation of isolator feet.

If motor stalling:

1. Remove the belt and test if the motor still stalls. (Manual mode in the Turntide Technician App.)
2. If motor runs *properly* without the belt:
 - **Slightly reduce the belt tension and test motor operation in small increments or upsize the belt if necessary.**
 - If you installed isolator feet, you may need to increase the belt by 2 sizes.
 - Note however, if the belt is too loose, it will slip and cause reduced airflow, excessive wear, and early failure.
3. If the motor is *still stalling* without a belt:
 - With the motor off, spin the motor by hand to feel bearings or if anything within the motor is clunking around.
 - Verify that power wiring is correctly wired. For example, are P2 & P3 correct or flipped?
 - Using the Turntide Technician App (**General** screen), verify that you have the correct motor model and voltage selected and that it matches the motor nameplate.
 - Confirm there aren't any rub-outs or exposed copper along the motor power wiring (Applicable check only if the motor has been in operation for some time).
 - If the motor continues to stall, contact Turntide Technical support.

