

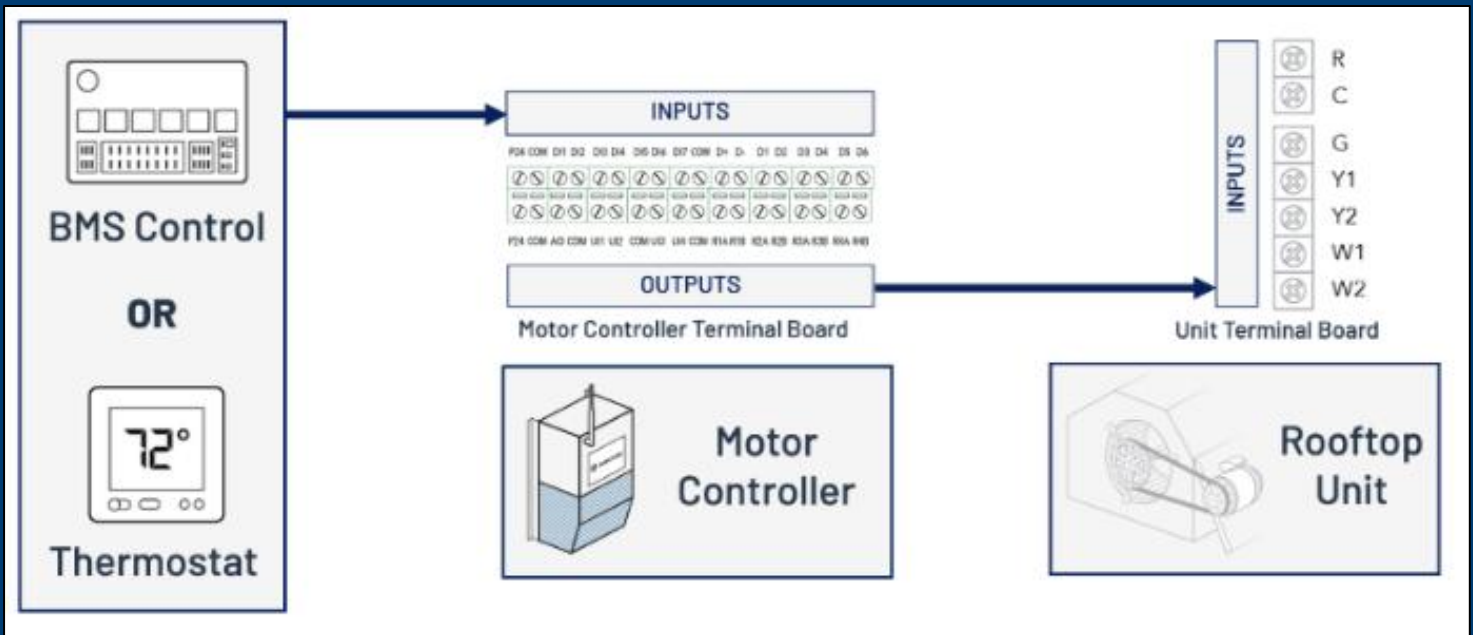

# Turntide Smart Motor System for RTU

## Full integration with Pre-Wired Motors

Document Version 2.0  
November 14, 2025





If your controller has a single **blue** cable prewired to the motor controller inputs, it is set up for Monitor Only, and you should reference the *Turntide Motor System Installation Guide for RTU Monitor Only Applications* on <http://support.turntide.com/>.

If you do not wish to use the new Monitor Only control wiring method but want to **maintain the Full Integration control wiring with a P06 or SL121 motor controller**, you **MUST** use the existing wiring harness. See **Special Case: Replacing Old Turntide Motor Controller with a P06 or SL121 Motor Controller** in the **Appendix**.

# Revision History

Document Revision Number	Description	Date
2.0	<p><b>Revised</b></p> <ul style="list-style-type: none"> <li>• Turntide address and contact Information</li> <li>• Front cover notes on Monitor Only versus Full Integration with specific inverters</li> </ul> <p><b>Removed</b></p> <ul style="list-style-type: none"> <li>• RMK content (<i>retained information where pertinent</i>)</li> <li>• Cloud and networking content</li> </ul>	November 14, 2025
1.0	<p>Initial release in this format with updates to original content:</p> <p><b>Added</b></p> <ul style="list-style-type: none"> <li>• Caution: “Ensure that motor controller wires are isolated by a minimum of 6mm or 0.25 in from power cables”</li> <li>• Disclaimer: “For proper installation and grounding of the antenna, please refer to national and local codes (e.g., U.S.: NFPA 70, National Electrical Code, Article 810, Canada: Canadian Electrical Code, Section 54).”</li> <li>• Caution: “Motor power harnesses are rated to 600 V and the Turntide controller and motor nameplates indicate operation up to 680 V.”</li> <li>• Warning: “Ensure that input power ground is terminated on the controller. If not properly grounded, the motor controller may not function correctly and could pose a safety hazard.”</li> <li>• Instructions for proper motor-pulley alignment and belt tension</li> <li>• More tool recommendations</li> <li>• Links to documents on Turntide Academy</li> <li>• Disclaimer on cover: “This manual is intended for use by qualified personnel only. It is not intended to supplant HVAC or electrical safety training.”</li> <li>• Best practices for removing the belt</li> </ul> <p><b>Removed</b></p> <ul style="list-style-type: none"> <li>• SL160 Motor Controller content and wiring</li> <li>• Prerequisite. Now technician is NO longer required to take Turntide training course.</li> </ul> <p><b>Clarification</b></p> <ul style="list-style-type: none"> <li>• Feet spacer bolts supplied with V01 and V02-D motors and mounting plate bolt sleeves supplied with V01 and V02 motors</li> </ul> <p><b>Updated</b></p> <ul style="list-style-type: none"> <li>• References to Vision XOi app removed and replaced with Turntide Technician App.</li> </ul>	May 1, 2023

# Conventions

<b>Bold</b>	<ul style="list-style-type: none"> <li>• Used in procedures for names of interface elements, such as buttons, fields, and menu items.</li> <li>• For names of apps.</li> <li>• For emphasis, typically when introducing a new concept or for the adverb “not.”</li> <li>• For measurements when necessary to distinguish from surrounding text</li> </ul>
<i>Italics</i>	References for names of additional Turntide guides and documents.
Links	Blue font for cross-references within document and to external sources.
<b>Note:</b>	Indicates information that can help a customer make better use of a Turntide product.
<b>Caution icon</b> 	Indicates an instruction that draws attention to the risk of damage to the product, process, or surroundings.
<b>Warning icon</b> 	Indicates an instruction that draws attention to risk of injury or death and tells the customer how to avoid the potential problem.

## Legal

The information in this document is subject to change without notice and should not be construed as a commitment by Turntide Technologies® or Software Motor Company. Turntide Technologies assumes no responsibility for any errors that may appear in this document. In no event shall Turntide Technologies be liable for incidental or consequential damages arising from use of this document or the software and hardware described in this document. © Turntide Technologies. All rights reserved.

## Contact

[support@turntide.com](mailto:support@turntide.com) | 11720 Amber Park Drive, Suite 160, Alpharetta, GA 30009 | [www.turntide.com](http://www.turntide.com)

## Contents

Audience.....	4
About this Installation Guide.....	5
Tools You'll Need.....	6
Included Items.....	7
Box 1: Turntide Smart Motor .....	7
Box 2: Turntide Smart Motor Controller .....	9
Box 3: RTU (Motor System) Installation Kit.....	10
Box 4: Motor Noise Isolation Feet Installation Kit .....	11
Control Wiring Method: Full Integration (Man-in-the-Middle).....	12
Installation Instructions.....	14
Task 1: Uninstall the existing motor and Install the Turntide Motor .....	14
Task 2: Confirm Motor Controller Configuration.....	17
Jumper Pins (P04, P05, and SL120 Motor Controllers) .....	17
Task 3: Install the Turntide Motor Controller .....	19
Step 4: Wire Components .....	20
Task 5: Start Up the System .....	23
Wiring Information for SL120 Motor Controller (Full Integration).....	25
Wiring Information for P04/P05 Motor Controllers (Full Integration).....	26
Appendix.....	27
How to Install Noise Isolation Feet.....	27
Installation Steps.....	28
KIT-ISLN-FT-101 Motor Noise Isolation Feet Installation on V01 and V02 Motors, Frames A, C, and D.....	29
KIT-ISLN-FT-201 Motor Noise Isolation Feet Installation on V01 and V02 Motors, Frame F .....	32
KIT-ISLN-FT-301 Motor Noise Isolation Feet Installation on V03 Motors, Frame H.....	35
Special Instructions for Installation on a Vertical Mounting Plate .....	38
Key Concepts .....	38
Supply and Return Air Sensors .....	43
Special Case: Replacing Old Turntide Motor Controller with a P06 or SL121 Motor Controller.....	44
How to Replace a P04/P05/SL120 with SL121/P06 Control Wiring.....	44
Best Practices for Installing Belt .....	45
Fan Pulley and Motor Pulley Alignment .....	48
Troubleshooting a Stalled Motor.....	48

The instructions in this guide are intended for a mechanical technician who is used to working with commercial RTU equipment.

You will have access to Support from Turntide Technical Services:

<http://support.turntide.com/>



**Required:** Follow all local and national electrical codes, safety compliance requirements, and common installation procedures.

This guide provides instructions on how to install and set up the Turntide Motor System, consisting of the Turntide Smart Motor and the Turntide Motor Controller. The contents of kits and recommended tools are also listed.







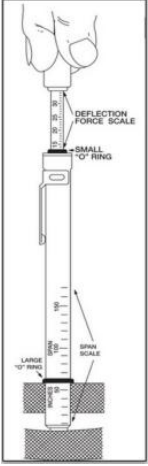
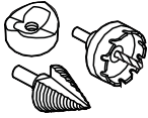
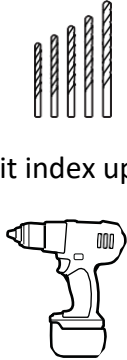
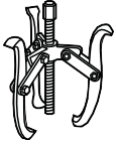
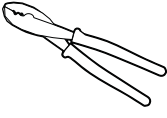
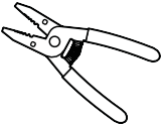

The following motors and motor controllers are featured in this guide:

- V series motors: V01, V02, and V3
- P04/P05 series motor controllers (Full Integration)
- SL120 series motor controller (Full Integration)
- P06 series motor controller (Monitor Only - Special Case Upgrade)
- SL121 series motor controller (Monitor Only - Special Case Upgrade)

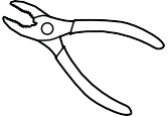

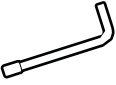
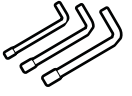
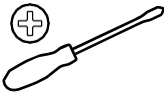
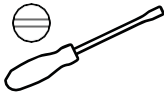
# Tools You'll Need

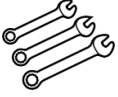
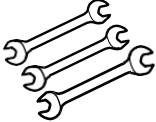
**Table 1 Tools List**

 <p>Belt tension gauge</p>	 <p>Uni-bit, hole sawor knock outs (for drilling hole into the RTU for the external unit antenna) <b>7/8 in bit</b></p>	 <p>Drill bit index up to <b>½ in</b>  Cordless drill</p>	 <p>Wheel puller 3-jaw for removing existing motor pulley</p>
 <p>Terminal (spade) crimp tool</p>	 <p>Wire strippers</p>	 <p>Multi-VOM meter</p>	 <p>Clamp amp meter</p>
 <p>Adjustable pliers</p>	 <p>Needle nose pliers</p>	 <p>Hex wrenches <b>2mm and 5mm</b></p>	 <p>Hex wrench set <b>1/8in - 3/8in</b></p>
 <p>Screwdriver Phillips</p>	 <p>Screwdriver slot</p>	 <p>Screwdriver, small terminating</p>	 <p>Nut driver <b>1/4in and 5/16in</b></p>
 <p>Combo Box/Open-End wrenches up to <b>3/4in</b> Ratcheting type recommended.</p>	 <p>Thin head access wrenches</p>	 <p><b>90 degree</b> offset wrenches</p>	<p>Additional supplies:</p> <ul style="list-style-type: none"> <li>• Silicon caulk</li> <li>• Retaining compound</li> <li>• Degreaser</li> <li>• Torque wrench</li> </ul>





## Included Items

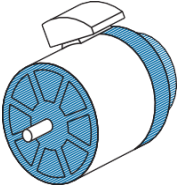
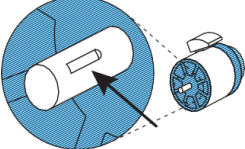

Everything typically required to install the Turntide Smart Motor System arrives in four separate boxes:

- Turntide Smart Motor
- Turntide Motor Controller
- Turntide Motor Systems (RTU) Installation Kit
- Motor Noise Isolation Feet Installation Kit (may not be included in your installation)

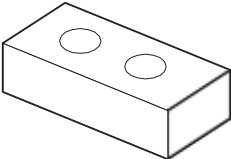
**Note:** Not all components in a kit will be used on every installation. Also, for unique applications, additional supplies may be required.

### Box 1: Turntide Smart Motor

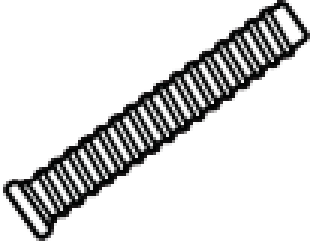
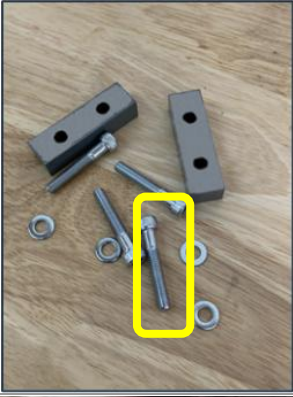





Item	Quantity
<p>Turntide motor</p> <p>Use appropriate equipment and ensure safe handling when moving/lifting motors. For motor weights, see the <b>Quick Reference Guide</b> on <a href="http://support.turntide.com/">http://support.turntide.com/</a></p>	 <p><b>1</b></p>
<p>Shaft Adapter &amp; Key (included only V01 Frame C motors)</p>	 <p><b>1</b></p>
<p> <b>Caution:</b> Motor power harnesses are rated to 600 V and the Turntide controller and motor nameplates indicate operation up to 680 V.</p>	<p><b>1</b></p>
<p>Power cable: Voltage rating on power cabling is AC voltage and any reference to 680 V is DC.</p> <ul style="list-style-type: none"> <li>• 600 VAC cable is acceptable to hold 680 VDC</li> <li>• 230 VAC solutions may reference up to 340 VDC</li> <li>• 460 VAC solutions may refer up to 680 VDC</li> <li>• 575 VAC solutions may refer up to 850 VDC</li> </ul>	
<p><b>Feet spacers</b> supplied with V01 and V02-D motors, which allow for better wrench access. (Do <b>NOT</b> use with noise isolation feet.)</p> <div style="display: flex; justify-content: space-around; align-items: center;">    </div>	<p><b>2</b></p>

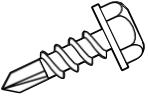
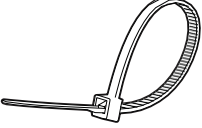

Item	Quantity
<p data-bbox="142 184 1182 220">Bolts for feet spacers supplied with V01 and V02-D motors (M6 x 1mm x 25 mm)</p>  	<p data-bbox="1377 184 1403 220">4</p>
<p data-bbox="142 653 768 808">Mounting plate bolt sleeves (5/16in x 9/16in x 3/8in) supplied with V01 and V02 motors, which allows uniform tightening of the nut. (Do <b>NOT</b> use with noise isolation feet.)</p>  	<p data-bbox="1377 653 1403 688">4</p>

## Box 2: Turntide Smart Motor Controller

Item	Quantity
<ul style="list-style-type: none"> <li>• Small antenna pre-installed on P06 and SL121 motor controllers</li> <li>• Small antennas shipped in the box with P04/P05 and SL120 motor controllers</li> </ul> <div data-bbox="646 426 935 621" data-label="Image"> </div> <p><b>Overview of two scenarios:</b></p> <ol style="list-style-type: none"> <li>1. <b>New installation of Turntide motor system at the site:</b> Manually attach the small antenna to the P04/P05 and SL120 controllers. The small antenna is pre-installed on the P06 and SL121 motor controllers, so no further action is required for these models.</li> <li>2. <b>You are replacing an existing Turntide motor controller</b> (for example, P04, P05, or SL120) with a newer motor controller (for example, P06 or SL121) <b>AND you have an existing RMK installed:</b> You will use the existing External Dual-Band Wi-Fi antenna with 3m wire that is already wired through the RTU (for RMK) and attach it to the P06 or SL121 <b>using the coaxial connector adapter that is provided.</b> You will complete this in <b>Step 4: Wire Components.</b></li> </ol> <div data-bbox="203 1094 1274 1402" data-label="Image"> </div>	
<p>(Pre-wired) Motor Controller and Control Cables</p> <div data-bbox="516 1457 1003 1640" data-label="Image"> </div> <ul style="list-style-type: none"> <li>• The SL121 and P06 motor controllers are prewired with a <b>blue</b> input cable, with a <b>600 V rating</b>.</li> <li>• The P04, P05, and SL120 motor controllers are prewired with a <b>white</b> input and a <b>black</b> output cable, <b>each with a 300 V rating</b>.</li> </ul> <p><b>All cables provided by Turntide are NOT rated for outdoor use.</b></p>	<p><b>1 Motor Controller and cable(s)</b></p>

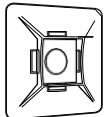
### Box 3: RTU (Motor System) Installation Kit

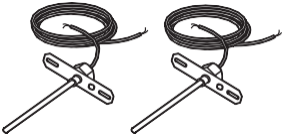
Item	Quantity
Wire nuts – <b>tan</b> and <b>red</b> for motor power cable 	<b>6 of each</b>
Wire nuts – <b>blue</b> for thermostat 	<b>8</b>
Hex head screws #10 x ¾ in 	<b>6</b>
Cable ties, 8 in 	<b>10</b>
Snap-in bushing – ½ in 	<b>6</b>
Snap-in bushing – ¾ in 	<b>6</b>
Snap-in bushing – 1 ¼ in 	<b>2</b>
Washer for #10 screw, ¼ in ID and 9/16 inch OD 	<b>4</b>
Cable tie holder, center mount 	<b>6</b>

Item	Quantity
<p><b>May arrive in a separate box.</b> Air temp sensors and a 10-inch wire included if applicable. Sensor appearance may vary.</p> 	<b>2</b>
<p>Turntide and Caution labels</p> 	<b>1 each</b>

### Box 4: Motor Noise Isolation Feet Installation Kit

May not be required on every motor installation.

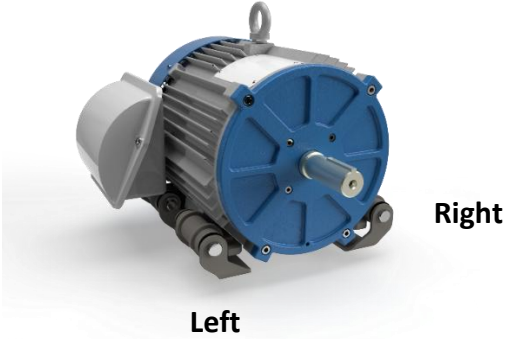
<p><b>KIT-ISLN-FT-101</b> Motor Noise Isolation Feet Installation on V01 and V02 Motors, Frames are A, C, D  <b>KIT-ISLN-FT-201</b> Motor Noise Isolation Feet Installation on V01 and V02 Motors, Frame F  <b>KIT-ISLN-FT-301</b> Motor Noise Isolation Feet Installation on V03 Motors, Frame H</p> <p>Example of V01 motor with noise isolation feet KIT-ISLN-FT-101 installed.</p>  <p>For Noise Isolation Feet Installation instructions, see <b>Appendix</b>.</p>	<b>1 Kit</b>
---	--------------

## Control Wiring Method: Full Integration (Man-in-the-Middle)

The motor controller interrupts the 24V signals between Thermostat and RTU. The thermostat sends stage signals to the motor controller via the **white** input cable. Once the motor reaches speed, the motor controller energizes the corresponding heating or cooling stage via the **black** output cable to the RTU.

- BMS or Thermostat is wired to the Turntide motor controller's inputs
- Turntide motor controller outputs are wired to the RTU unit terminal board, to communicate which mode the RTU should operate in
- The motor will reach its target speed before the RTU turns on its cooling or heating mechanisms
- Provides an opportunity to remotely modify the operating mode of the RTU to validate operation

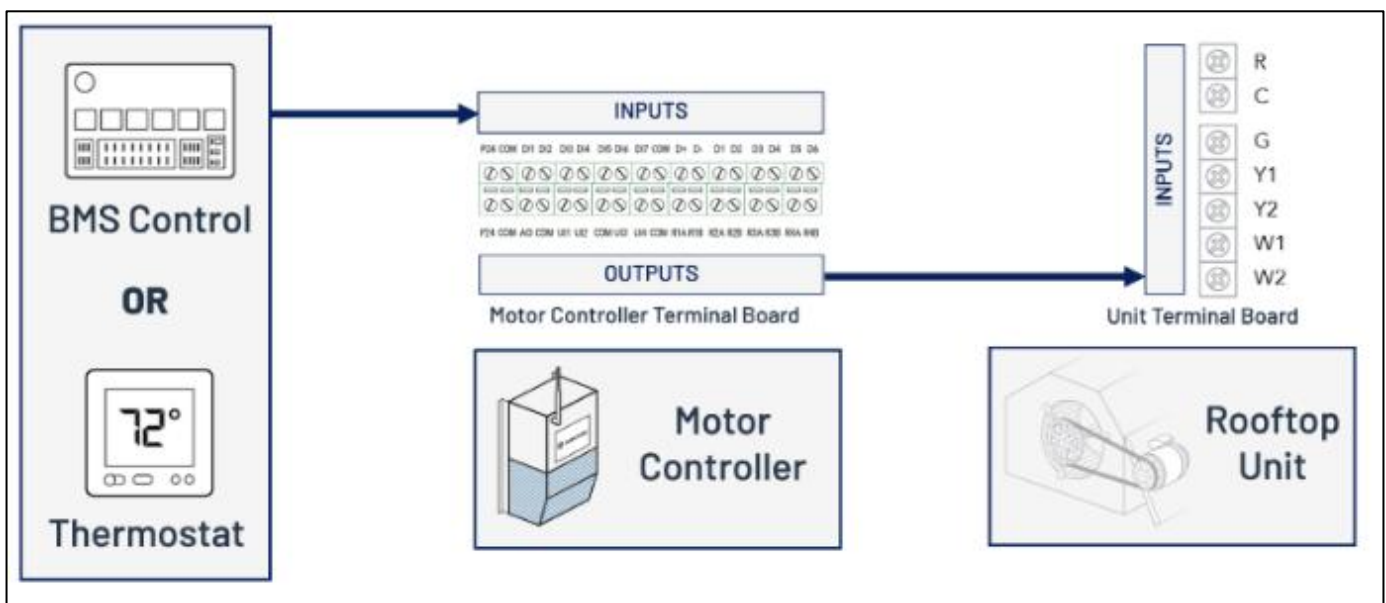

The P04, P05, and SL120 motor controllers are prewired with a **white** input and **black** output cable.

- The **white** input wired in parallel with the thermostat 24V signals to the RTU.
- The **black** cable wired for 24V Common.

**IMPORTANT:** The P06 and SL121 Turntide motor controllers are prewired for **Monitor Only** control.

- If your controller has a single **blue** cable prewired to the motor controller inputs, it is set up for Monitor Only, and you should reference the *Turntide Motor System Installation Guide for RTU Monitor Only Applications* on <https://support.turntide.com/>
- If you do not wish to use the new Monitor Only control wiring method but want to **maintain the Full Integration control wiring with a P06 or SL121 motor controller, you MUST use the existing wiring harness.** See [Special Case: Replacing Old Turntide Motor Controller with a P06 or SL121 Motor Controller](#) in the [Appendix](#).

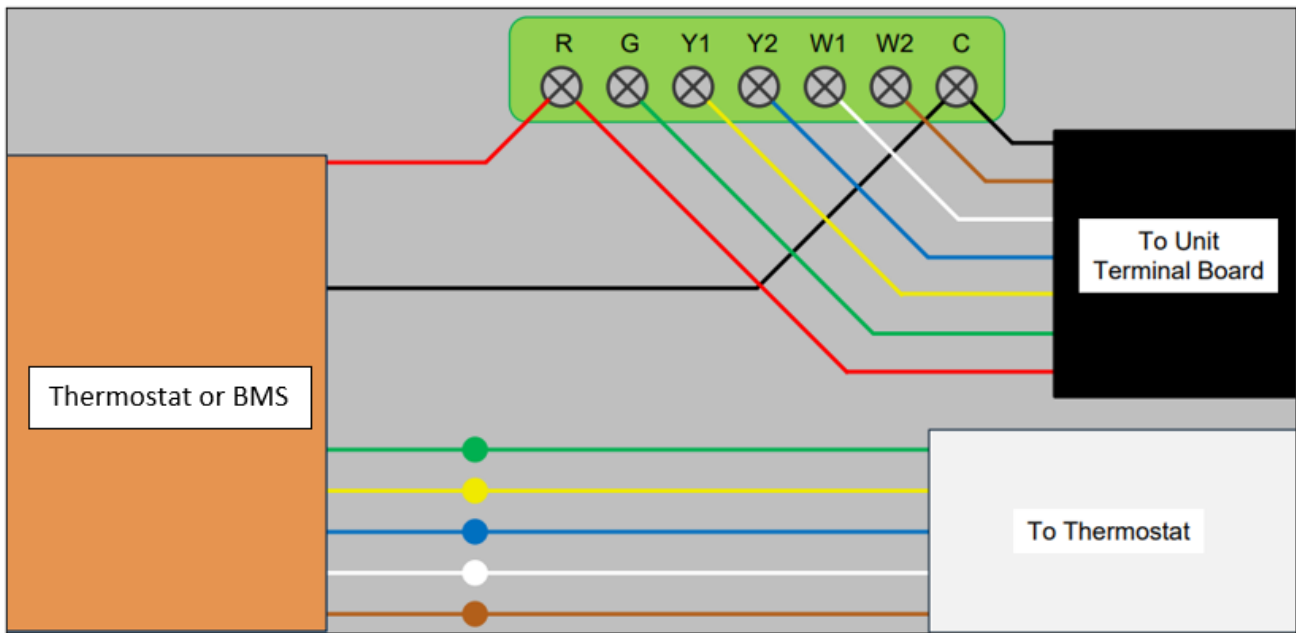

**Figure 1 Full Integration Control Wiring Method**

The **white** input cable (labeled as **To Thermostat**) is wired to the thermostat, to receive the 24V signals.

The **black** output cable (labeled as **To Unit Terminal Board**) is wired to the RTU terminals to energize heating and cooling stages on the unit once the motor reaches stage speed.



Follow these simple step-by-step instructions to replace the existing motor in a common Rooftop Unit (RTU) with a new Turntide Smart Motor System.

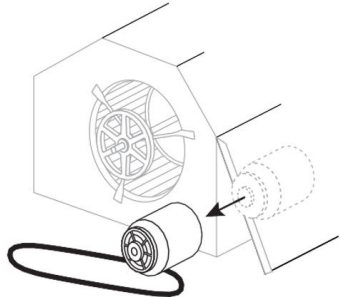

## Task 1: Uninstall the existing motor and Install the Turntide Motor

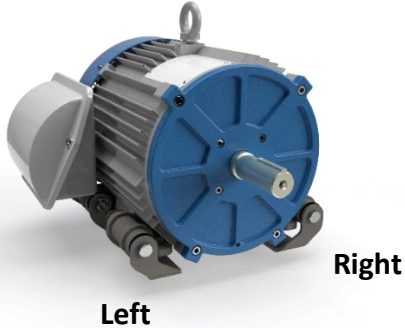
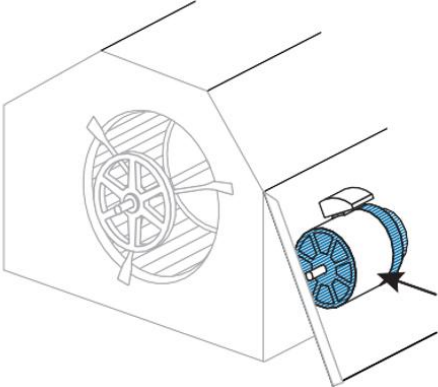
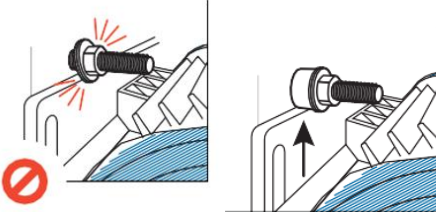
<p><b>1</b></p>	<p>Isolate all incoming power to RTU unit using normal Lock Out/Tag Out and local code requirements and verify that all power is turned off to the unit.</p>	
<p><b>2</b></p>	<p>Remove the existing belt and motor. In most cases, it's easier to remove the motor pulley before removing the motor.</p>	

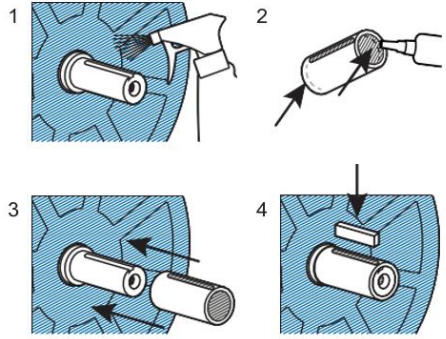
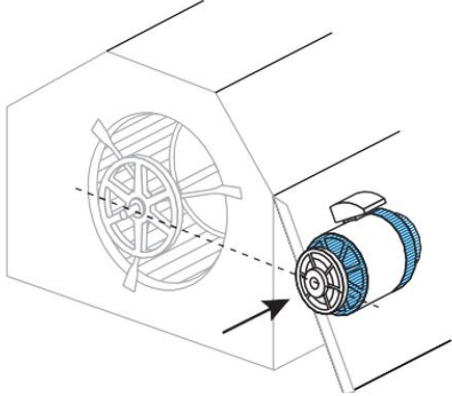
<p><b>3</b></p>	<p><b>Determine if you should install the Noise Isolation Feet to the base of the new motor.</b> Consider the following points:</p> <ol style="list-style-type: none"> <li>Noise isolation feet increase the overall height of the Turntide motor as follows: <ul style="list-style-type: none"> <li>KIT-ISLN-FT-101 on a V01 motor raises the shaft height 0.5 inches (1.27 cm)</li> <li>KIT-ISLN-FT-101 on a V02-D motor raises the shaft height 0.5 inches (1.27 cm)</li> <li>KIT-ISLN-FT-201 on a V02-F motor raises the shaft height 0.125 inches (0.32 cm)</li> <li>KIT-ISLN-FT-301 on a V03 motor raises the shaft height 0.62 inches (1.57 cm)</li> </ul> </li> <li>You may have to increase the size of the belt once the isolator feet are installed.</li> <li>It takes more time to complete the installation when you add noise isolation feet.</li> <li>Is the location where you are installing the motor a noise-sensitive area and therefore requires noise isolation feet?</li> </ol> <p><b>YES, to installing noise isolation feet?</b> Follow the instructions in the <a href="#">Appendix</a> of this guide <b>at this point in your installation process.</b></p>	<p>Example of V01 motor with noise isolation feet KIT-ISLN-FT-101 installed.</p>  <ul style="list-style-type: none"> <li><b>KIT-ISLN-FT-101</b> Motor Noise Isolation Feet Installation on V01 and V02 Motors, Frames are A, C, D</li> <li><b>KIT-ISLN-FT-201</b> Motor Noise Isolation Feet Installation on V01 and V02 Motors, Frame F</li> <li><b>KIT-ISLN-FT-301</b> Motor Noise Isolation Feet Installation on V03 Motors, Frame H</li> </ul>
<p><b>4</b></p>	<p>Install the Turntide Smart Motor to the existing motor mounting plate.</p>	
<p><b>5</b></p>	<p>In some cases, tightening the motor plate nut is not possible. The provided bolt-sleeves allow for proper nut tightening.</p>	

<p><b>6</b></p>	<p><b>For V01 Frame C motors ONLY.</b>          The Turntide V01 Frame C motor has a 5/8 in shaft and the existing motor pulley is 7/8 in ID.</p> <p>You must install the shaft adapter as follows:</p> <ol style="list-style-type: none"> <li>1. Clean the shaft with a degreaser.</li> <li>2. Apply a small amount of Loctite 620 retaining compound.</li> <li>3. Install the shaft adapter with the set screw towards the shaft end.</li> <li>4. Insert the extended height shaft key and tighten the set screw to lock the shaft adapter in place.</li> </ol>	
<p><b>7</b></p>	<p>Reinstall original motor pulley. If the existing pulley shows signs of excessive wear, it should be replaced. Replacing worn components will ensure that the system is running most efficiently.</p>	
<p><b>8</b></p>	<p><b>Install the belt.</b>          Use the recommended visual step-by-step process in <a href="#">Best Practices for Installing Belt</a> in the <a href="#">Appendix</a>.</p>	

## Task 2: Confirm Motor Controller Configuration

Turntide motor controllers are designed for several applications.

- Jumpers (P04, P05, and SL120) are used to configure the motor controller for a specific application
- Switches (P06 and SL121) are used to configure the motor controller for a specific application.: Information on the switches for P06 and SL121 motor controllers are described in the **Turntide Motor System Installation Guide for RTU Monitor Only Applications** on <http://support.turntide.com/>

Before connecting the controller to the Turntide motor, verify the controller configuration.

### Jumper Pins (P04, P05, and SL120 Motor Controllers)

<b>Digital Input Mode</b> jumpers	Determine the inputs the motor controller recognizes.
<b>Universal Input (UI)</b> jumpers	Define the connected device type. <ul style="list-style-type: none"> <li>• Currently UI3 and UI4 are used in applications with Supply and Return Air sensors.</li> <li>• Setting the respective jumpers across pins 1 &amp; 2 configure the control to respond to the resistive load of the thermistor.</li> </ul>



**Input mode selection must be jumpers 1&2 and 3&4 or 1&2 and 5&6.**

Motor Controller Model	Modbus EOL Jumper	Digital Input Mode Jumper	Universal Input Mode Jumpers			
			UI1	UI2	UI3	UI4
P04W	J96	J96	J5125	J111	J112	J113
P05	J96	J96	J5125	J111	J112	J113
SL120	J10	J10	J11	J12	J13	J14

Modbus EOL Selection		
Pin Selections	Mode	Examples
<b>1 &amp; 2</b> 	Installed: Enables EOL Resistor (End of line) Removed: Disables EOL Resistor (End of line)	Install if wiring to terminals D+/D is end of daisy chain.

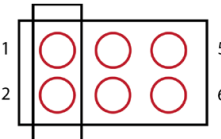
Digital Input Mode Selection		
Pin Selections	Mode	Examples
<b>3 &amp; 4</b> 	Enables digital inputs LOGIC or dry contact mode.	Install if S1 through S7 will be used to receive contact closures for control.
<b>5 &amp; 6</b> 	Enables digital inputs 24VAC signaling mode.	Install if S1 through S7 will be used to receive 24VAC input signal from existing BMS or thermostat.

Universal Input Mode Selection		
Pin Selections	Mode	Examples
<b>1 &amp; 2</b> 	<b>Resistive/LOGIC:</b> Returns resistance of connected element or ON/OFF if declared as resistive or LOGIC mode respectively.	<b>Resistive:</b> 2 wire 10K $\Omega$ thermistor  <b>LOGIC:</b> Dry contact closure = ON Dry contact open = OFF
<b>3 &amp; 4</b> 	<b>Voltage:</b> 0-10V signal ended voltage input.	3-wire device with external power source that provides 0-10V signal. (1 signal, 1 common, 1 power)
<b>5 &amp; 6</b> 	<b>Current:</b> 0-20mA current input.	3-wire device with external power source that provides a 0-20mA signal. (1 signal, 1 common, 1 power)

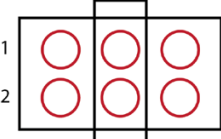
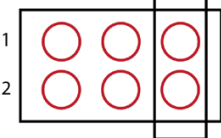
To ensure the motor controller jumper pins are set correctly for an RTU installation, consult the following:

**Table 2 Motor Controller Jumper Pins (Image rotated 90 degrees)**

<p><b>SL120 Motor Controller Jumper Pins</b></p> <ul style="list-style-type: none"> <li>• Confirm J11 and J12 jumper bridges are set on pins 1&amp;2.</li> <li>• Confirm J10 jumper bridges are set on pins 1&amp;2 and 5&amp;6.</li> </ul>	<p><b>P05 Motor Controller Jumper Pins</b></p> <ul style="list-style-type: none"> <li>• Confirm J5125 jumper bridges are set on pins 1&amp;2.</li> <li>• Confirm J111 bridges are set on 1&amp;2 and J96 bridges on pins 1&amp;2 and 5&amp;6.</li> </ul>
---	--

## Task 3: Install the Turntide Motor Controller

**REMINDER:** The **P06** and **SL121** Turntide motor controllers are prewired for **Monitor Only** control.

- If your controller has a single **blue** cable prewired to the motor controller inputs, it is set up for Monitor Only, and you should reference the *Turntide Motor System Installation Guide for RTU Monitor Only Applications* on <http://support.turntide.com/>
- If you do not wish to use the new Monitor Only control wiring method but want to **maintain the Full Integration control wiring with a P06 or SL121** motor controller, you **MUST** use the existing wiring harness. See **Special Case: Replacing Old Turntide Motor Controller with a P06 or SL121 Motor Controller** in the **Appendix**.

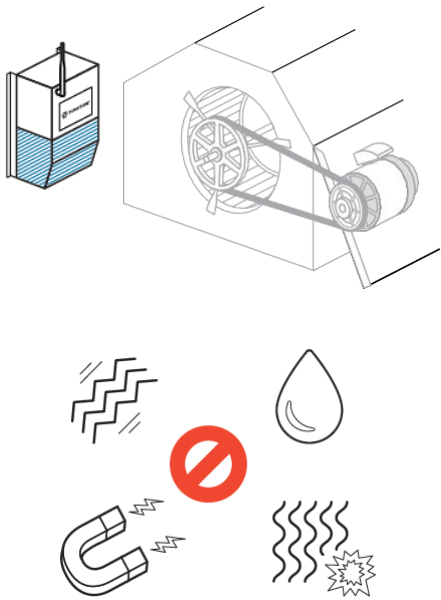
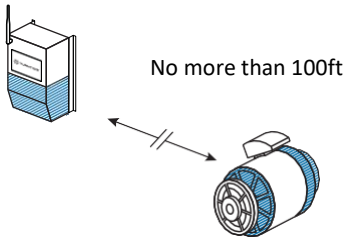

**Required:** Ensure that motor controller wires are isolated by a minimum of 6mm or 0.25 in from power cables and never route them through a common conduit or cable tray.

<p><b>1</b></p>	<p>Mount the Turntide Motor Controller inside the RTU—ideally in the blower cabinet—using caution not to penetrate the cabinet with the screws. Ensure the controller is far from excessive vibration, moisture, electromagnetic interference, and explosive/corrosive vapors.</p> <p><b>Note:</b> If a suitable location is <b>NOT</b> available, please contact Turntide Technical Services.</p> <p>Do <b>NOT</b> install the controller on the floor in an area where pooled water or splashing water will affect it. You may have to install a channel slot (Unistrut or a similar riser) to elevate the controller so it is not in the lowest part of the cabinet where moisture can build up.</p>	
<p><b>2</b></p>	<p>If a longer Motor Power Cable is needed, Turntide offers a 10M (~33Ft) option. Contact Turntide Technical Services for distances greater than 10M.</p>	

## Step 4: Wire Components

<p><b>1</b></p>	<p>Refer to <b>Wiring Information</b> for physical layout of the wires.</p>	<ul style="list-style-type: none"> <li>• <b>Wiring Information for SL120 Motor Controller (Full Integration)</b></li> <li>• <b>Wiring Information for P04/P05 Motor Controllers (Full Integration)</b></li> </ul>
<p><b>2</b></p>	<ol style="list-style-type: none"> <li>1. Remove thermostat wires from the unit connection point.</li> <li>2. Connect the white <b>To thermostat</b> cable from the Turntide Motor Controller and cut excess wire to length required.</li> </ol>	<p>BMS or Thermostat</p>
<p><b>3</b></p>	<ol style="list-style-type: none"> <li>1. Connect the black <b>To unit terminal board</b> cable from the Turntide Motor Controller to unit connection point where thermostat wires were just removed.</li> <li>2. Cut excess wire to length required (applies to all motor controllers).</li> </ol>	
<p><b>4</b></p>	<ol style="list-style-type: none"> <li>1. Insert bushing into the motor electrical box.</li> <li>2. Install the ferrules end of the motor power cable to the Turntide Motor Controller and unterminated leads to the Turntide Smart Motor.</li> <li>3. Cut excess length from the raw end of the cable to required length, leaving ample slack for future servicing.</li> </ol>	

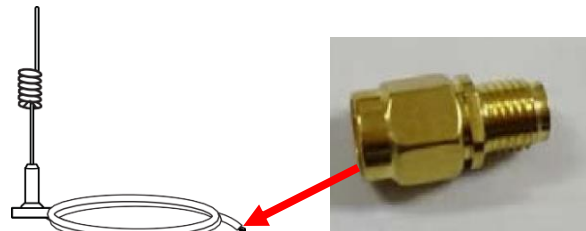
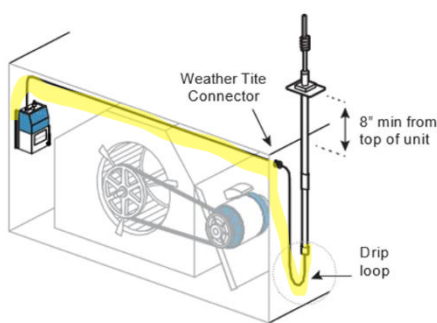

<p><b>5</b></p>	<p>Connect the induction motor power wires to the Turntide Motor Controller. If the original induction motor had separate overload wires, then they must be connected.</p> <p>P05 labeled U, W, V, and SL120 labeled L1, L2, L3.</p>	
<p><b>6</b></p>	<p>Relocate induction motor power wires from the <b>Load</b> side of the fan contactor to the <b>Line</b> side, so that the Turntide Motor Controller has an unswitched power supply.</p> <div style="background-color: #f0f0f0; padding: 10px; border: 1px solid #ccc;">  <p><b>Warning: Ensure that input power ground is terminated on the controller. The ground wire from the motor to the controller does not provide sufficient grounding.</b> If not properly grounded, the motor controller may not function correctly and could pose a safety hazard. Ensure you have a dedicated ground wire.</p> </div>	
<p><b>7a</b></p>	<p><b>Air Sensor Installation</b> If you are <b>NOT</b> using air sensors, skip this task (5a) and task (5c). Air sensors are <b>NOT</b> intended for installations exposed to weather.</p> <p>Install the supply air sensor downstream of the coil and heat exchanger, and the return air sensor in the return duct inlet. (Sensors are identical and can be installed in either location.) For more information, see <a href="#">Supply and Return Air Sensors</a> in the <a href="#">Appendix</a>.</p> <p>All cables provided by Turntide are <b>NOT</b> rated for outdoor use.</p>	

<p><b>7b</b></p>	<p>For horizontally ducted units, install the supply air sensor through blower deck just beyond the heat exchanger, and the return air sensor where duct enters unit.</p> <p>For units equipped with an economizer, install the return air sensor upstream of the economizer such that it senses the indoor return air, not the outside air, taking care not to impede damper blade operation.</p>	
<p><b>7c</b></p>	<p>Wire sensors to the Turntide Motor Controller per configuration specific wiring diagrams.</p> <p>Sensors are <b>not</b> polarity sensitive.</p>	
<p><b>8</b></p>	<p>If you are replacing an existing Turntide motor controller (for example, P04, P05, or SL120) with a newer motor controller (for example, P06 or SL121) AND you have an existing RMK installed:</p> <p>Use the existing External Dual-Band Wi-Fi antenna with 3m wire that is already wired through the RTU (for RMK) and attach it to the P06 or SL121 <b>using the coaxial connector adapter that is provided.</b></p>	

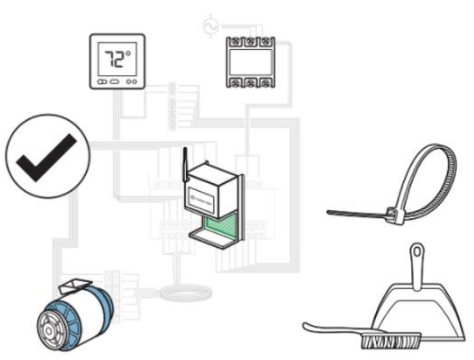
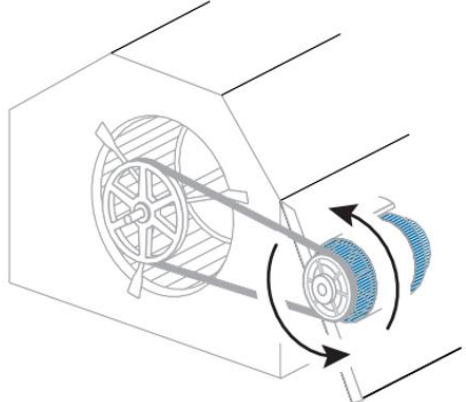
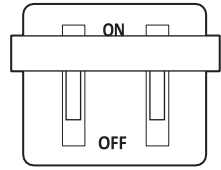
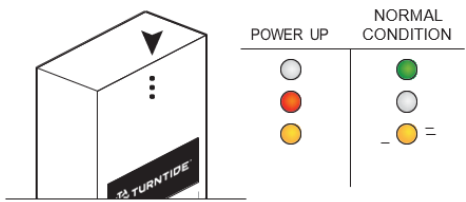

## Task 5: Start Up the System

<p><b>1</b></p>	<ol style="list-style-type: none"> <li>1. Verify that all wiring is correct and wire terminations are tight and secure.</li> <li>2. Install cable ties around any loose wires and clean blower cavity of any debris from installation.</li> </ol>	
<p><b>2</b></p>	<p>Turn the fan pulley by hand and verify that the motor pulley and fan rotate freely.</p>	
<p><b>3</b></p>	<p>Turn on power to the unit.</p>	
<p><b>4</b></p>	<p>Inspect the Turntide motor controller's LEDs for the correct run sequence.</p> <p>Upon power up:</p> <ul style="list-style-type: none"> <li>• The <b>red</b> and <b>yellow</b> LEDs will illuminate briefly</li> <li>• The <b>green</b> LED will illuminate solid</li> </ul>	

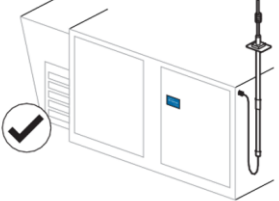
<p><b>5</b></p>	<p>At this point, you must use the <b>Turntide Technician App</b> to commission the motor.</p> <p>A smart phone with the Turntide Technician mobile app is necessary for connecting to the motor controller. <i>You cannot complete the installation without using the app.</i></p> <p>See the <b>Turntide Technician App User Guide</b> on <a href="http://support.turntide.com/">http://support.turntide.com/</a></p>	
<p><b>6</b></p>	<p>Affix the Turntide label on the exterior of the blower access panel and the Caution label on the blower housing.</p>	
<p><b>7</b></p>	<p>Confirm all access panels are re-installed and secure on unit. Ensure all unit disconnects are in the ON position and remove all materials and tools from roof/location.</p>	

# Wiring Information for SL120 Motor Controller (Full Integration)

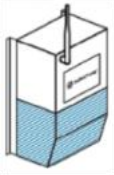

Turntide Motor Controller

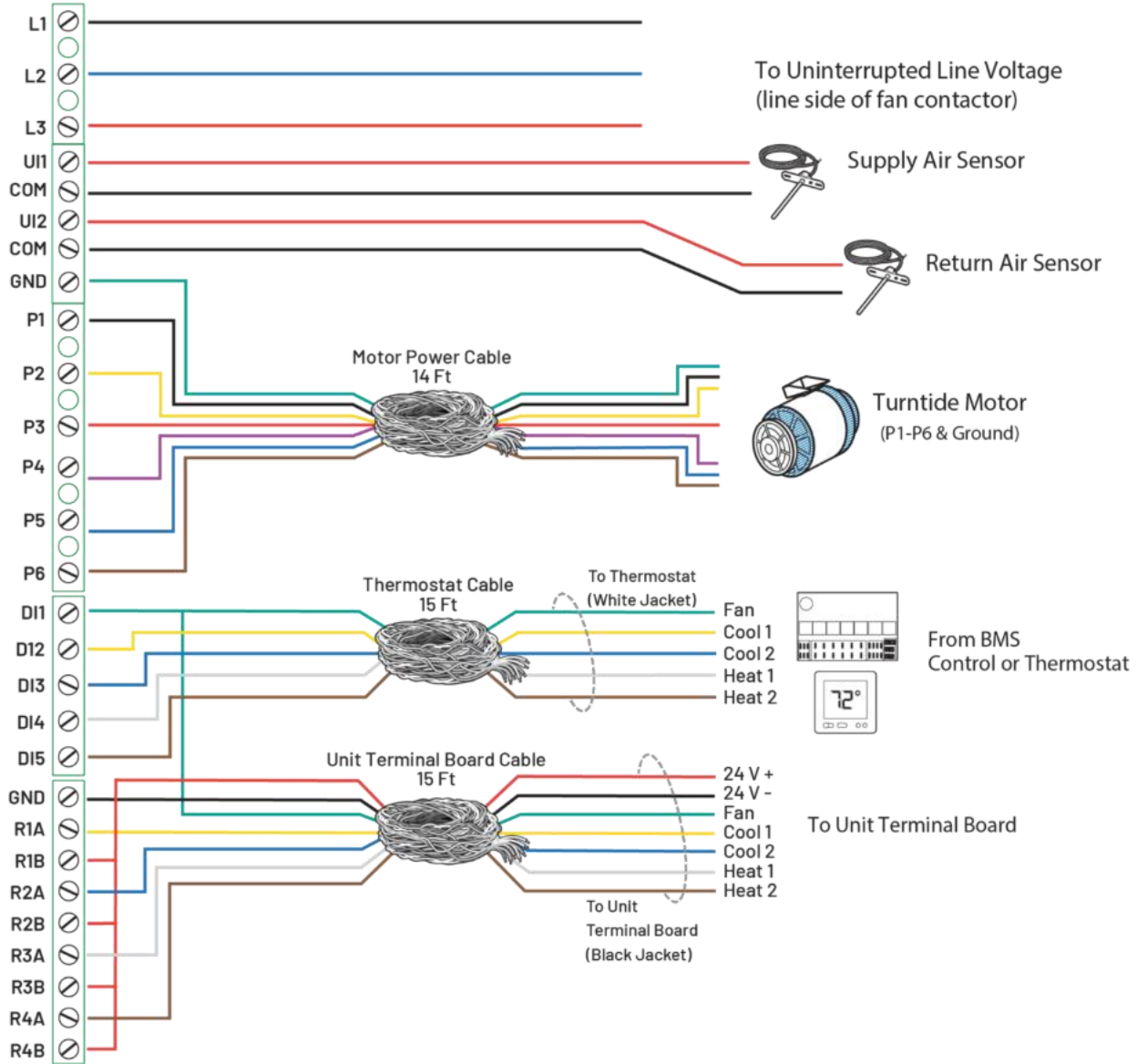

# Wiring Information for P04/P05 Motor Controllers (Full Integration)

## Wiring Information

P04 / P05 Motor Controllers

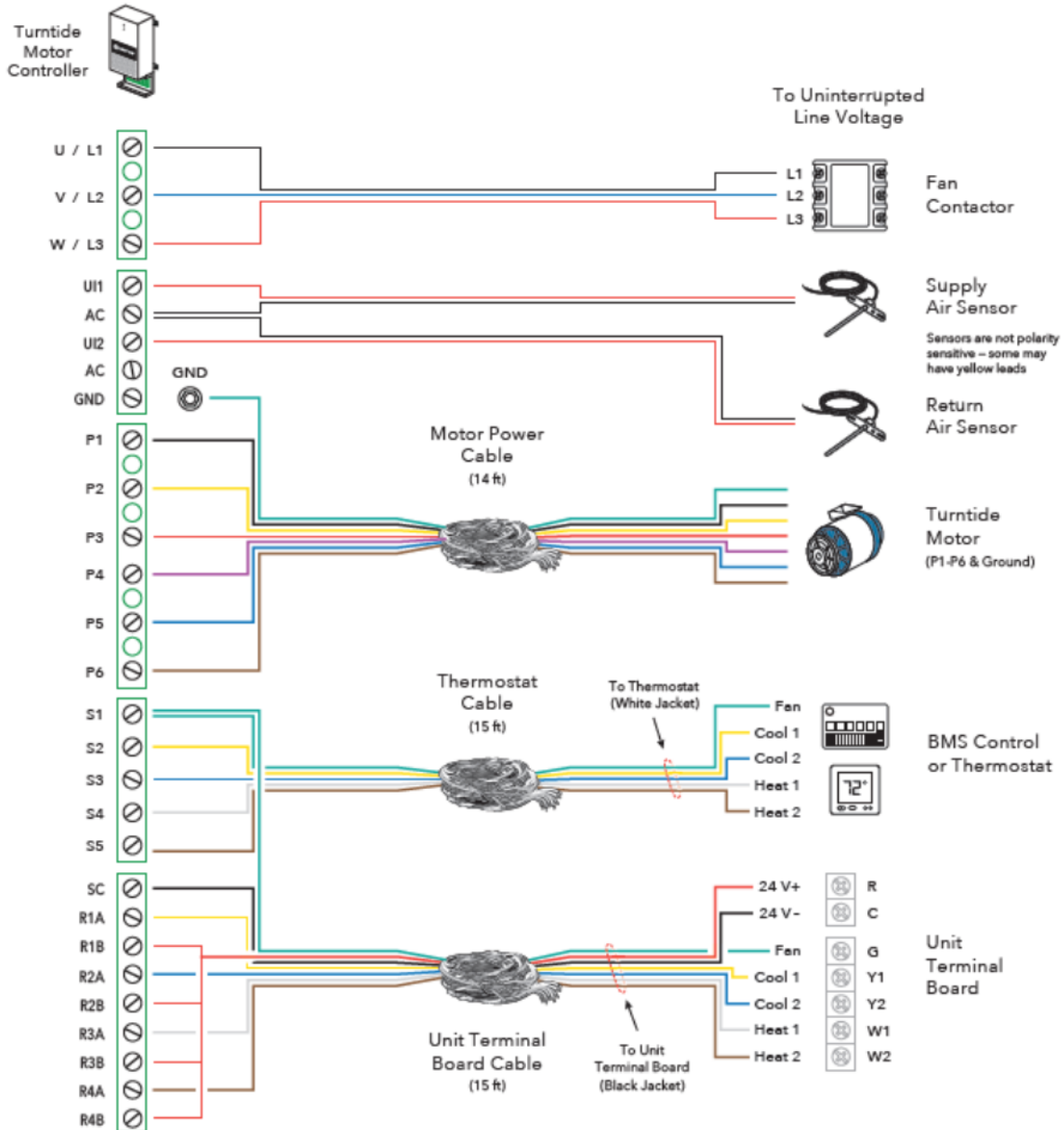

For P06 and SL121 wiring, refer to the *Turntide Motor System Installation Guide for RTU Monitor Only Applications* on <http://support.turntide.com/>.

## How to Install Noise Isolation Feet

**Table 3 Noise isolation kits matched with motors**

KIT	SKU (motor and frame)	Notes
<b>KIT-ISLN-FT-101</b>	V01-0300-2-A00 V01-0300-4-A00 V01-0300-2-C00 V01-0300-4-C00 V01-0300-6-C00 V01-0300-2-D00 V01-0300-4-D00 V01-0300-6-D00 V02-0500-2-D00 V02-0500-4-D00 V02-0500-6-D00	<b>Frames are A, C, D</b> V02 motors with a 143/145T frame size require KIT_ISLN-FT-101.
<b>KIT-ISLN-FT-201</b>	V01-0300-2-F00 V01-0300-4-F00 V01-0300-6-F00 V02-0500-2-F00 V02-0500-4-F00 V02-0500-6-F00	<b>Frame F</b> V01-F motors, which are less than 3hp motors with a 182/184T frame size require KIT-ISLN-FT-201.
<b>KIT-ISLN-FT-301</b>	V03-1500-4-H00 V03-1500-6-H00	<b>Frame H</b>

**Table 4 Torque required for Nylon-Patch Thread-Locking Fasteners**

Kit	Fastener	Torque Inch Pounds	Torque Foot Pounds	Torque Nm
<b>KIT-ISLN-FT-101</b>	Two <b>M6</b> x 1mm x 16mm Nylon-Patch Thread-Locking Fasteners	170.0 in-lbs ± 11.2 in-lbs	14 ft-lbs ± 1 ft-lbs	19.2 Nm ± 1.3 Nm
<b>KIT-ISLN-FT-201</b>	Four <b>M6</b> x 1mm x 16mm Nylon-Patch Thread-Locking Fasteners	170.0 in-lbs ± 11.2 in-lbs	14 ft-lbs ± 1 ft-lbs	19.2 Nm ± 1.3 Nm
<b>KIT-ISLN-FT-301</b>	Eight <b>M6</b> x 1mm x 16mm Nylon-Patch Thread-Locking Fasteners	170.0 in-lbs ± 11.2 in-lbs	14 ft-lbs ± 1 ft-lbs	19.2 Nm ± 1.3 Nm
	Eight <b>M8</b> x 1.25mm x 16mm Nylon-Patch Thread-Locking Fasteners	330.0 in-lbs ± 19.5 in-lbs	27.5 ft-lbs ± 1.6 ft-lbs	37.3 Nm ± 2.2 Nm

## Installation Steps

1. Identify the Turntide motor and frame size using the codes found on the nameplate of the motor and match it to a [Noise Isolation Kit in Table 3 Noise isolation kits matched with motors](#). Verify that your package contains the correct noise isolation feet for your motor and motor frame.

**Figure 2 Example Motor V01 with Frame A**

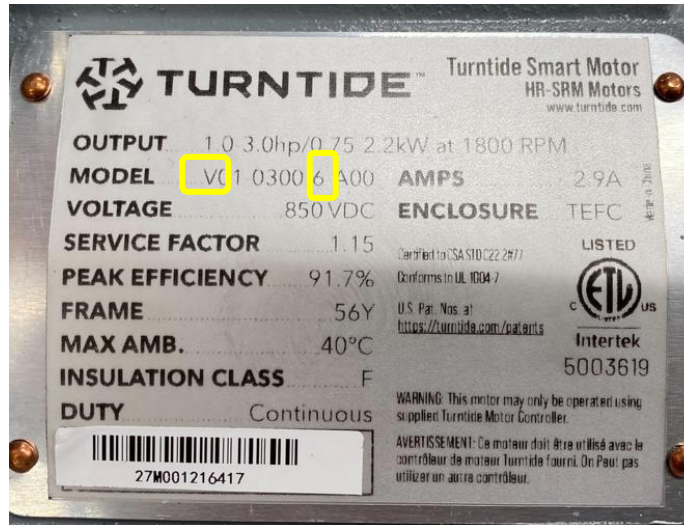

Go to instructions for your kit:

- [KIT-ISLN-FT-101 Motor Noise Isolation Feet Installation on V01 and V02 Motors, Frames A, C, and DD](#)
- [KIT-ISLN-FT-201 Motor Noise Isolation Feet Installation on V01 and V02 Motors, Frame F](#)
- [KIT-ISLN-FT-301 Motor Noise Isolation Feet Installation on V03 Motors, Frame H](#)

**Important:** Do **NOT** use feet spacers or bolt sleeves with noise isolation feet.

## KIT-ISLN-FT-101 Motor Noise Isolation Feet Installation on V01 and V02 Motors, Frames A, C, and D

**Important:** Assumes you have removed the existing mounting plate. Do **NOT** use feet spacers or bolt sleeves with noise isolation feet.

### Instructions for KIT-ISLN-FT-101 Motor Noise Isolation Feet Installation on V01 and V02 Motors, Frames A, C, and D

#### 1 Examine the new noise isolation feet:

- The feet in KIT-ISLN-FT-101 are **NOT** symmetrical. They are identified as *Left* and *Right*, when facing the shaft end of the motor.
- The shorter barrel faces toward the motor shaft end. (A sticker indicates the direction.)
- Color indicator lines on the isolation foot upper and lower sections indicate which pieces go together when reassembling the isolation foot.
- The left foot is marked **yellow** the right foot is marked **white**.

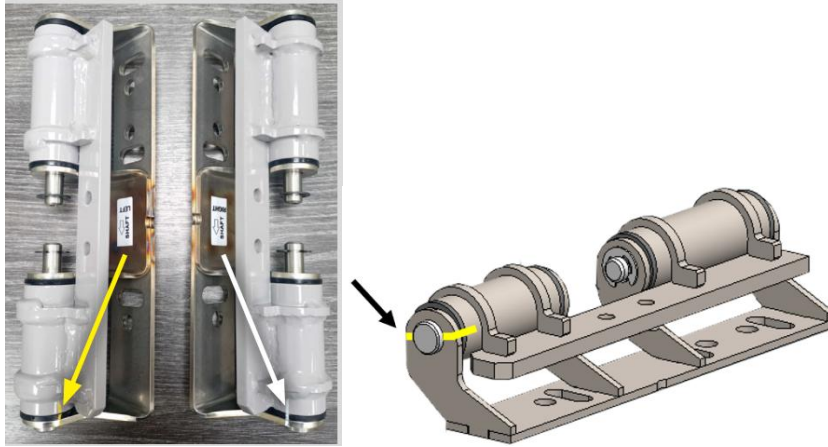

#### 3 Disassemble the noise isolation feet to allow for easier installation:

Remove the E-clips from the clevis pins, sliding clevis pins out, so as to separate the lower foot section from the upper foot section.

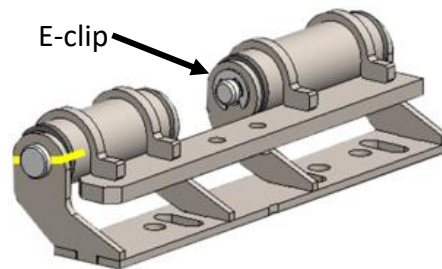

Instructions for KIT-ISLN-FT-101 Motor Noise Isolation Feet Installation on V01 and V02 Motors, Frames A, C, and D

- 3** Install the **lower section** of the Left and Right noise isolation feet **to the mounting plate** BUT do **not** tighten the bolts yet! The Left foot is marked **yellow**, and the Right foot is marked **white**.

*The position of the motor (and therefore noise isolation feet) relative to the mounting plate is determined based on where the pulley/belt is on the blower fan as well.*

Lower section of foot installed on the mounting plate.

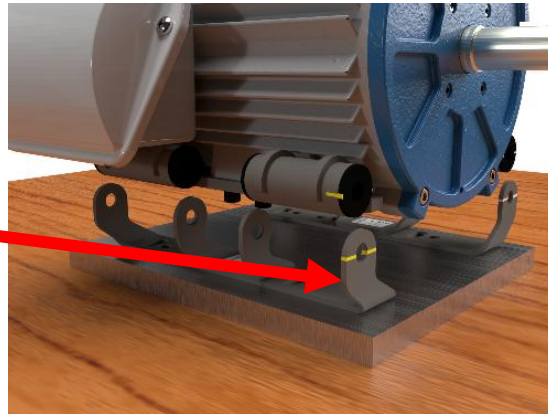

**Special Cases:**

**Narrow Mounting Plate:** If you are using a narrow mounting plate with a V01 motor and KIT-ISLN-FT-101, you will need filler blocks to allow the feet to hang over the edge of the mounting plate.

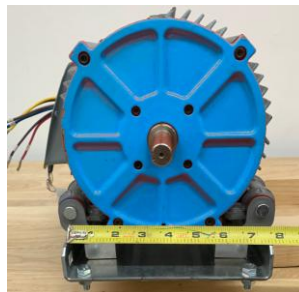
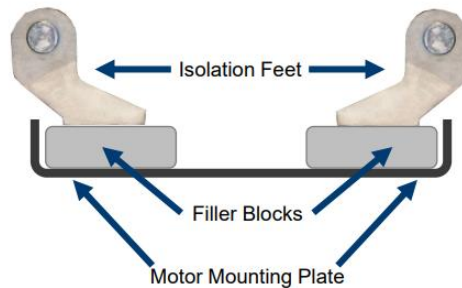

**Vertical Mounting Plate:** If your mounting plate is positioned vertically, at this point, follow instructions in [Special Instructions for Installation on a Vertical Mounting Plate](#) before proceeding with Step 5.

**Instructions for KIT-ISLN-FT-101 Motor Noise Isolation Feet Installation on V01 and V02 Motors, Frames A, C, and D**

- 4**
1. Install the upper section of the Left and Right noise isolation feet **to the motor**.
  2. Ensure that bolts connecting motor isolation feet to the motor body are torqued to specifications.
- KIT-ISLN-FT-101** for motors V01 and V02 (A, C, and D frames) includes:  
 Two M6 x 1mm x 16mm Nylon-Patch Thread-Locking Fasteners  
 Torque: **14 ft-lbs ± 1 ft-lbs** (19.2 Nm ± 1.3 Nm)

Upper section of foot  
 installed on the motor.

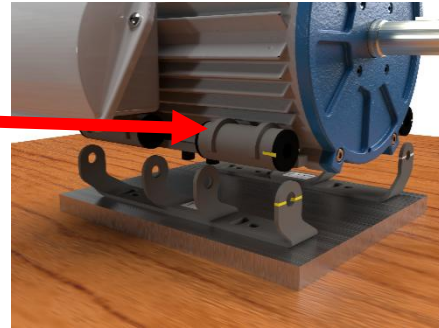

- 5**
1. Reconnect the upper and lower sections of the noise isolation feet using the clevis pins and E-clips.
  2. Carefully align the motor on the mounting plate on a flat surface.
  3. Fully tighten the lower noise isolation feet bolts.

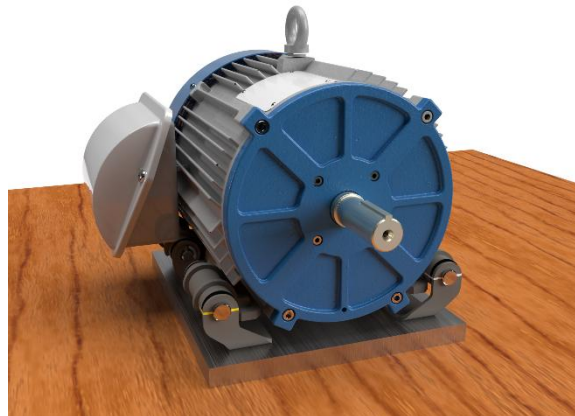

- 6** Reinstall the motor and mounting plate assembly in the RTU.

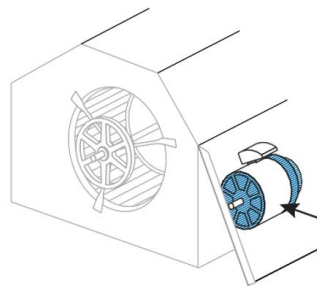

Go back to **Task 1: Uninstall the existing motor and Install the Turntide Motor, Step 7.**

## KIT-ISLN-FT-201 Motor Noise Isolation Feet Installation on V01 and V02 Motors, Frame F

**Important:** Assumes you have removed the existing mounting plate. Do **not** use feet spacers or bolt sleeves with noise isolation feet.

### Instructions for KIT-ISLN-FT-201 Motor Noise Isolation Feet Installation on V01 and V02 Motors, Frame F

#### 1 Examine the new noise isolation feet:

1. The feet in KIT-ISLN-FT-201 are **NOT symmetrical**. They are identified as Left and Right, when facing the shaft end of the motor.
2. Color indicator lines on the isolation foot upper and lower sections indicate which pieces go together when reassembling the isolation foot. The left foot is marked **yellow** the right foot is marked **white**.

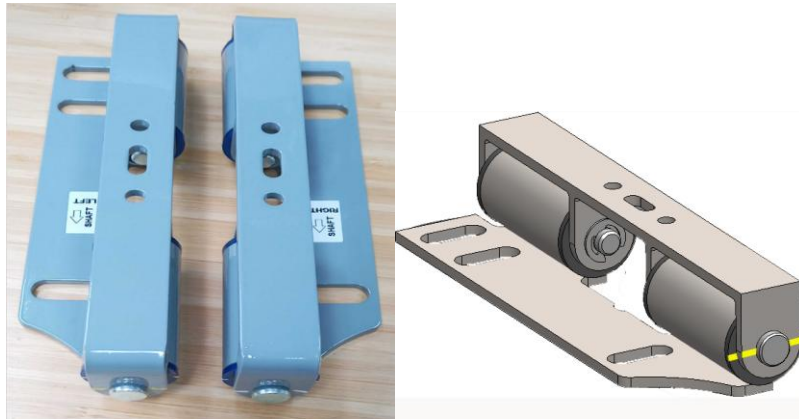

#### 2 Disassemble the noise isolation feet:

Remove the E-clips from the clevis pins, sliding clevis pins out, so as to separate the lower foot section from the upper foot section.

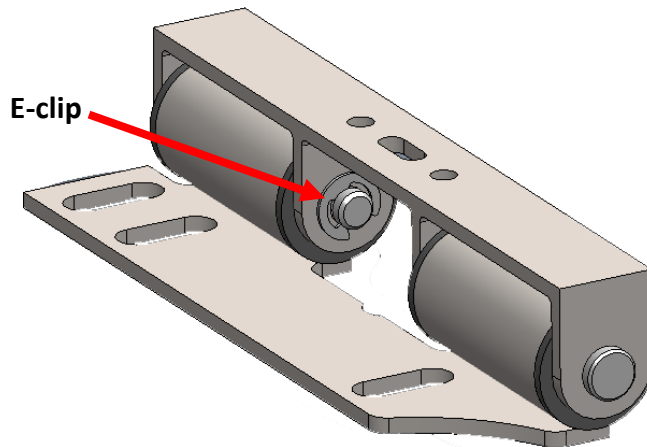

**Instructions for KIT-ISLN-FT-201 Motor Noise Isolation Feet Installation on V01 and V02 Motors, Frame F**

- 3** Install the **lower section** of the Left and Right noise isolation feet to the mounting plate BUT do **NOT** tighten the bolts yet! The Left foot is marked **yellow** the Right foot is marked **white**. *The position of the motor (and therefore noise isolation feet) relative to the mounting plate is determined based on where the pulley/belt is on the blower fan as well.*

Lower section of foot installed on the mounting plate

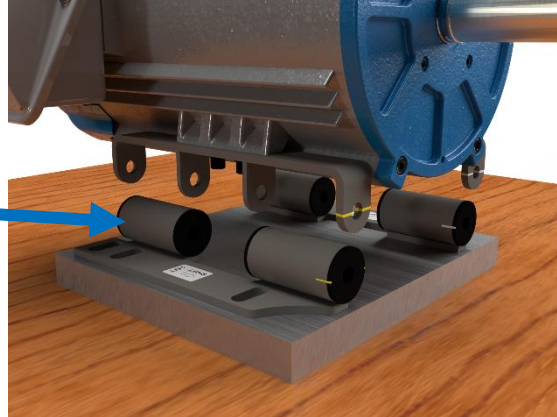

- 4**
1. Install **the upper section** of the Left and Right noise isolation feet to the motor.
  2. Ensure that bolts connecting motor isolation feet to the motor body are torqued to specifications.
- KIT-ISLN-FT-201** Motor Noise Isolation Feet Installation on V01 and V02 Motors, Frame F includes:
- Four M6 x 1mm x 16mm Nylon-Patch Thread-Locking Fastener
- Torque: **14 ft-lbs ± 1 ft-lbs** (19.2 Nm ± 1.3 N)

Upper section of foot installed on the motor.

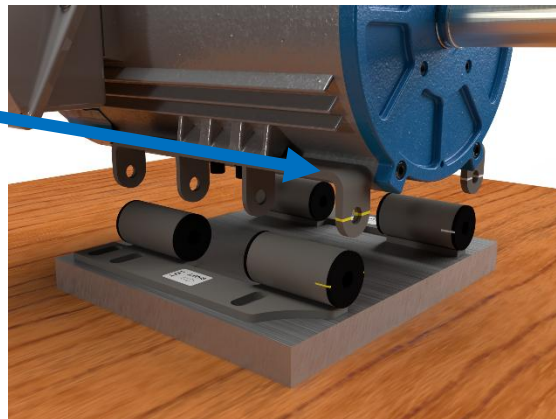

**Instructions for KIT-ISLN-FT-201 Motor Noise Isolation Feet Installation on V01 and V02 Motors, Frame F**

- 5**
1. Reconnect the upper and lower sections of the noise isolation feet using the clevis pins and E-clips.
  2. Carefully align the motor on the mounting plate on a flat surface.
  3. Fully tighten the lower noise isolation-feet bolts to the mounting plate.

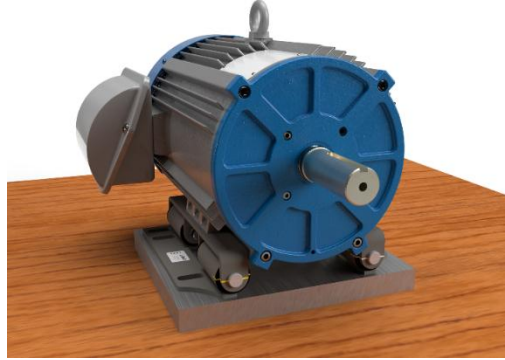

- 6** Reinstall the motor and mounting plate assembly in the RTU.

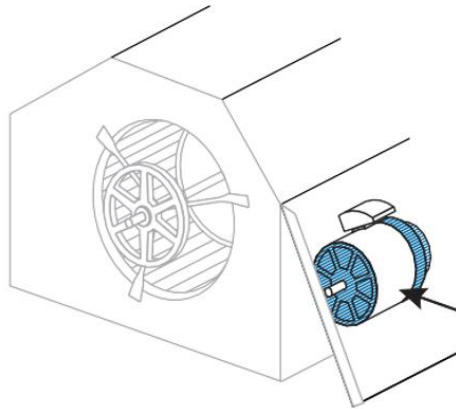

Go back to [Task 1: Uninstall the existing motor and Install the Turntide Motor, Step 7](#)

## KIT-ISLN-FT-301 Motor Noise Isolation Feet Installation on V03 Motors, Frame H

**Important:** Assumes you have removed the existing mounting plate. Do **not** use feet spacers or bolt sleeves with noise isolation feet.

### Instructions for KIT-ISLN-FT-301 Motor Noise Isolation Feet Installation on V03 Motors, Frame H

- 1 Examine the new noise isolation feet:**  
The feet in KIT-ISLN-FT-301 are **symmetrical**.



- 2 Disassemble the noise isolation feet:**  
Remove the E-clips from the clevis pins, sliding clevis pins out, so as to separate the lower foot section from the upper foot section.

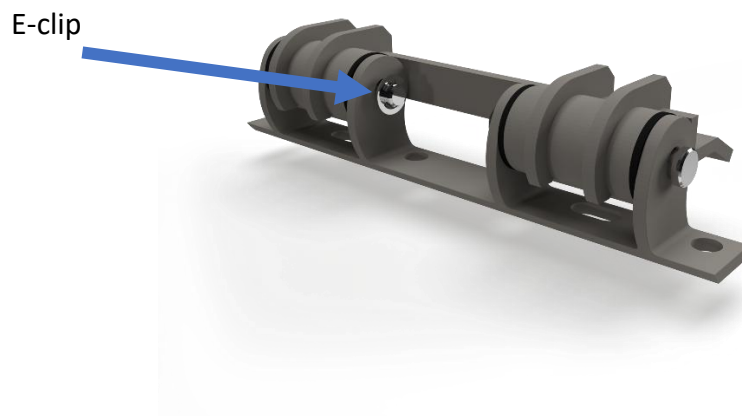

**Instructions for KIT-ISLN-FT-301 Motor Noise Isolation Feet Installation on V03 Motors, Frame H**

- 3** Install the **lower section** of the Left and Right noise isolation feet **to the mounting plate** BUT do **NOT** tighten the bolts yet!

*The position of the motor (and therefore noise isolation feet) relative to the mounting plate is determined based on where the pulley/belt is on the blower fan as well.*

Lower section of foot installed on the mounting plate

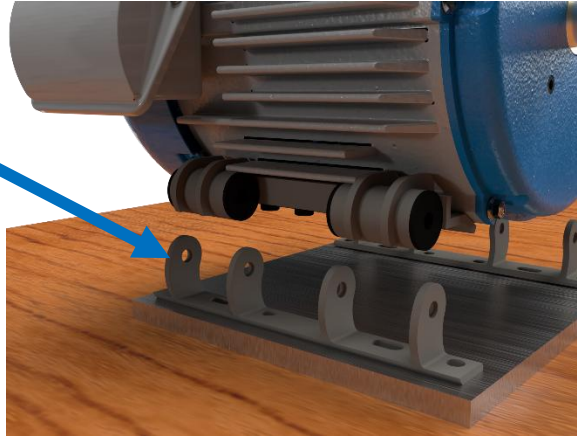

- 4**
1. Install the upper section of the noise isolation feet **to the motor**.
  2. Ensure that bolts connecting motor isolation feet to the motor body are torqued to specifications. Depending on the housing of your V03 motor, you will use the M6 or M8 fasteners.

**KIT-ISLN-FT-301** Motor Noise Isolation Feet Installation on V03 Motors, Frame H includes:

Eight M6 x 1mm x 16mm Nylon-Patch Thread-Locking Fasteners  
Torque: **14 ft-lbs ± 1 ft-lbs** (19.2 Nm ± 1.3)

Eight M8 x 1.25mm x 16mm Nylon-Patch Thread-Locking Fasteners  
Torque: **27.5 ft-lbs ± 1.6 ft-lbs** (37.3 Nm ± 2.2 Nm)

Upper section of foot installed on the motor.

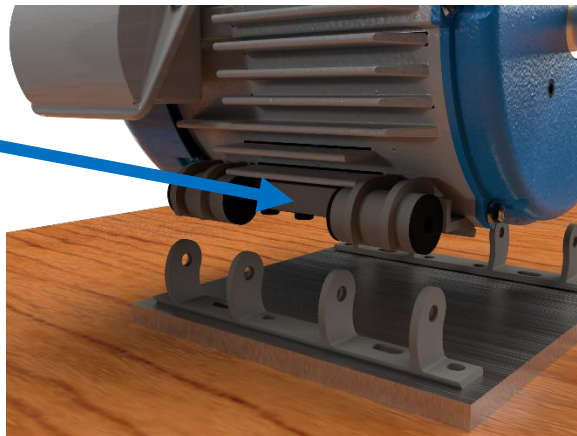

**Instructions for KIT-ISLN-FT-301 Motor Noise Isolation Feet Installation on V03 Motors, Frame H**

- 5**
1. Reconnect the upper and lower sections of the noise isolation feet using the clevis pins and E-clips.
  2. Carefully align the motor on the mounting plate on a flat surface.
  3. Fully tighten the lower noise isolation feet bolts.

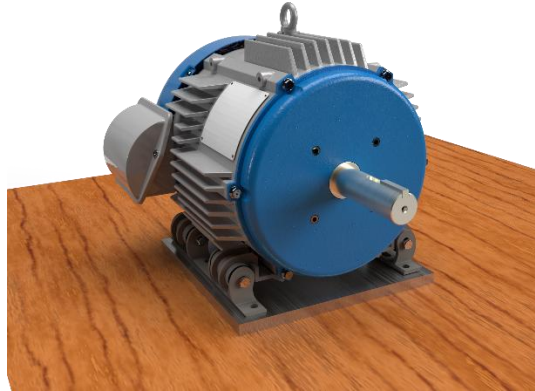

- 6** Reinstall the motor and mounting plate assembly in the RTU.

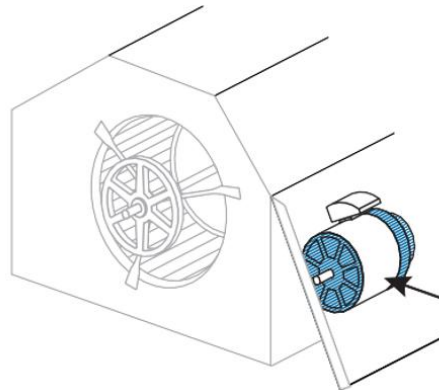

Go back to **Task 1: Uninstall the existing motor and Install the Turntide Motor, Step 7.**

## Special Instructions for Installation on a Vertical Mounting Plate

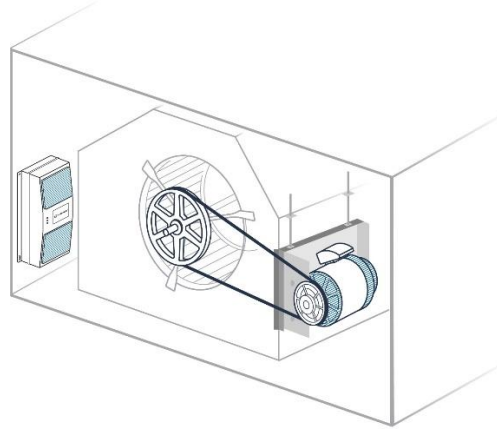

### Key Concepts

#### BEFORE:

In an existing vertical mounting plate installation, the bolts are positioned with the thread facing the motor. As you can see in the example image, the bolt extends towards the motor.

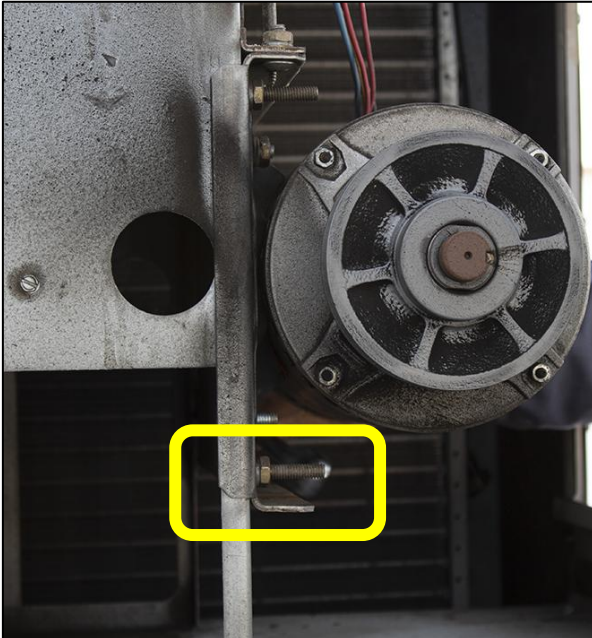

#### AFTER:

You will be reversing the mounting bolts (180 degrees) with the noise isolation feet installation. As you can see in the example image, the bolt thread now extends **towards** the RTU. This allows you to access the nut when belt tension adjustment is necessary.

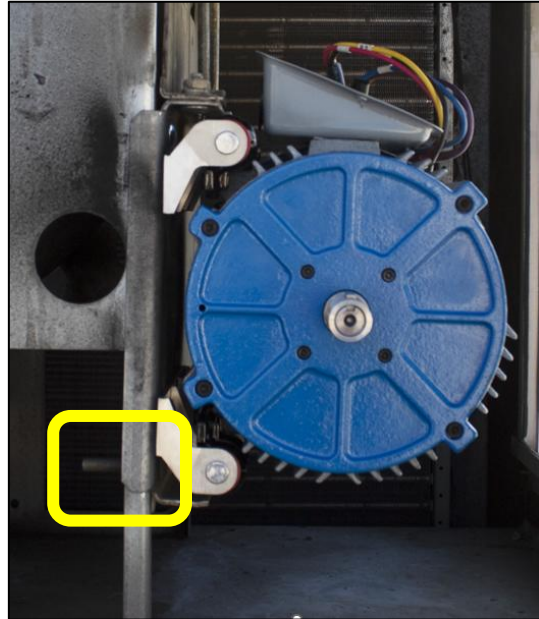

In your *existing* Turntide motor installation, the carriage bolts may have sleeves.

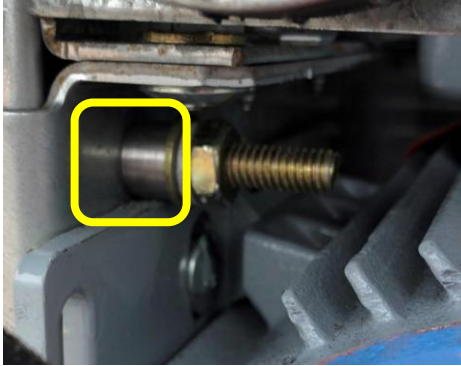

You will **not** use sleeves with the installation of the noise isolation feet.

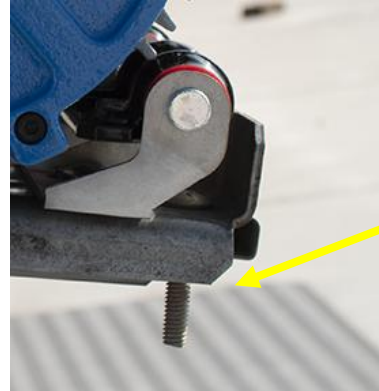

No sleeve used

**Before you begin, note the following:**

1. Assumes you have removed the existing mounting plate.
2. **Important:** Feet spacers, bolt sleeves, and filler blocks are **not** applicable to this configuration.
3. You will reuse all the existing mounting bolts but turn all the bolts 180 degrees.
4. In the upper left corner of the mounting plate, use a **5/16in x 1in** carriage bolt. Using a shorter bolt ensures that it will **NOT** protrude into the blower housing.
5. You might have to shift the entire assembly down to get a good fit. This is necessary if the blower housing is preventing ample space for nut installation on the bolt in the upper right corner and proper bolt seating.

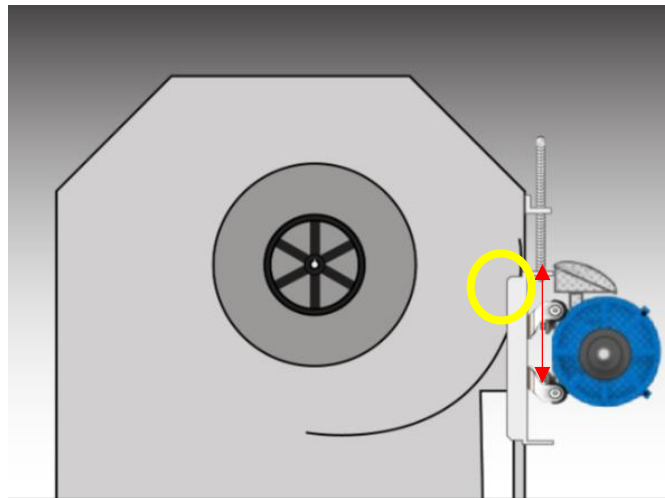

1. Install the **5/16in x 1in** carriage bolt in the upper left corner of the **top** of mounting plate.
2. Install the remaining bolts and add push nut bolt retainer to the bolts nearest the shaft/belt.

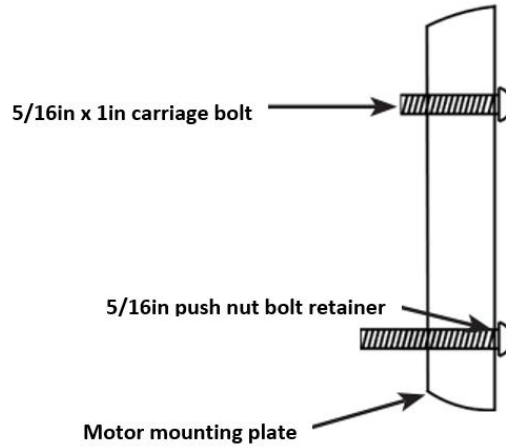
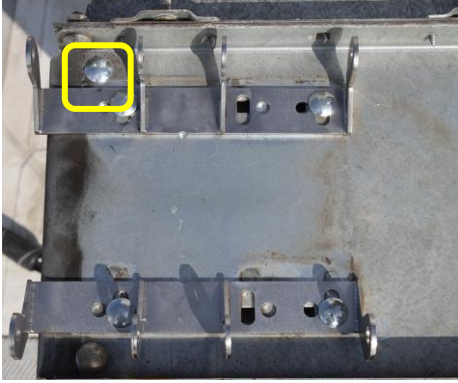

2. Install the **lower section** of the Left and Right noise isolation feet **to the mounting plate** BUT do **not** tighten the bolts yet! The Left foot is marked **yellow**, and the Right foot is marked **white**. *The position of the motor (and therefore noise isolation feet) relative to the mounting plate is determined based on where the pulley/belt is on the blower fan as well.*

Lower section of foot installed on the mounting plate.

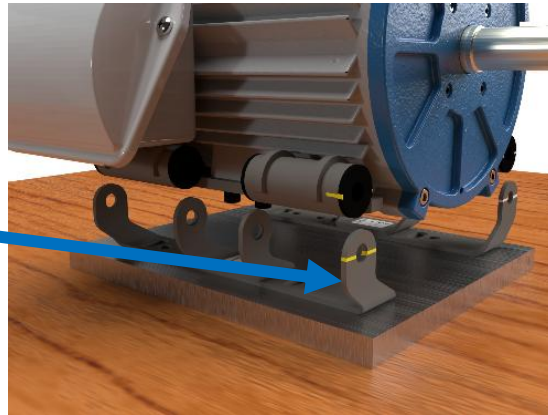

- 3**
1. Install the upper section of the Left and Right noise isolation feet **to the motor**.
  2. Ensure that bolts connecting motor isolation feet to the motor body are torqued to specifications.  
**KIT-ISLN-FT-101** for motors V01 and V02 (A, C, and D frames) includes:  
Two M6 x 1mm x 16mm Nylon-Patch Thread-Locking Fasteners  
Torque: **14 ft-lbs ± 1 ft-lbs** (19.2 Nm ± 1.3 Nm)

Upper section of foot installed on the motor.

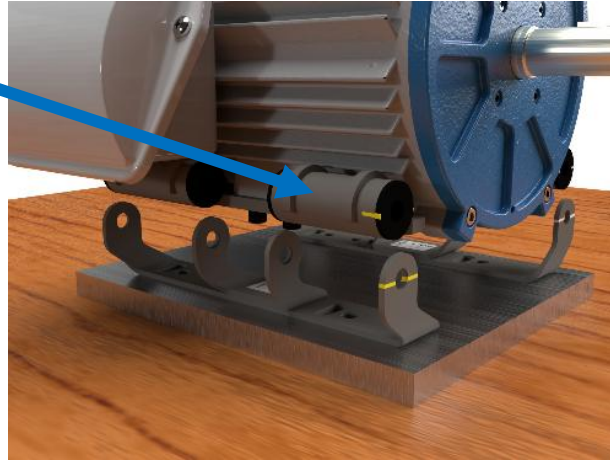

- 4**
1. Reconnect the upper and lower sections of the noise isolation feet using the clevis pins and E-clips.
  2. Carefully align the motor on the mounting plate on a flat surface.
  3. Fully tighten the lower noise isolation feet bolts.



**5** Reinstall the motor and mounting plate assembly in the RTU.

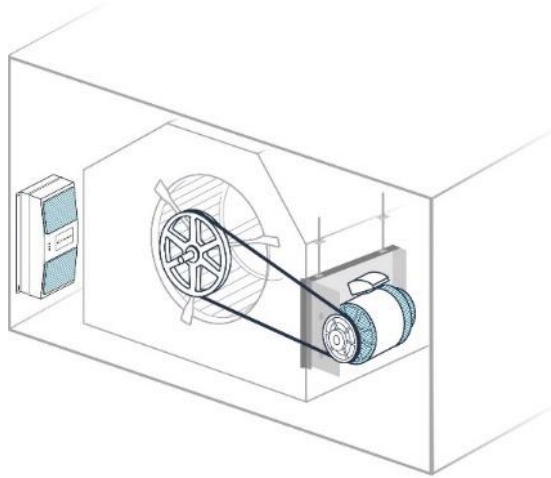

Go back to **Task 1: Uninstall the existing motor and Install the Turntide Motor, Step 7.**

When you install a supply-air temperature sensor, it changes the sequence of operations of the motor system in all flows.

1. If the unit is in heating mode and the supply-air temperature is greater than 140degF, the Turntide motor will increase speed to increase airflow.
2. If the unit is in cooling mode and the supply-air temperature is less than 50degF, the Turntide motor will increase speed to increase airflow.
3. If the sensors are not installed, the motor system maintains its typical control method dictated by the installed flow.
4. Supply and return temperatures are viewable in BOS for connected motors and on the Technician App for all motors.
5. As a failsafe measure, if the supply and return air sensors malfunction, then the motor system maintains the Turntide control method (40/75/90) or any custom setpoints that were installed. A malfunction includes if the Turntide motor controller cannot read any values from the sensor or if the values are invalid.

# Special Case: Replacing Old Turntide Motor Controller with a P06 or SL121 Motor Controller

The P04, P05, and SL120 motor controllers are prewired with a **white** input and **black** output cable.

- The **white** input wired in parallel with the thermostat 24V signals to the RTU.
- The **black** cable wired for 24V Common.

## How to Replace a P04/P05/SL120 with SL121/P06 Control Wiring

1. When removing the existing controller, retain the existing **BLACK** and **WHITE** wire harnesses.
2. Remove and retain the orange jumper wires that are connected to terminals **R1B, R2B, R3B, and R4B**.
3. Remove the blue wire harness from the new Turntide motor controller. *It is not used in this application.*
4. Install the orange jumper wires in the new motor controller terminals **R1B, R2B, R3B, and R4B**.
5. Connect the wires of the **BLACK** harness as follows:
  - a. Red to R1B (this is already connected to the orange jumper)
  - b. Black to COM
  - c. Yellow to R1A
  - d. Blue to R2A
  - e. White to R3A
  - f. Brown to R4A
  - g. Green to DI1 (this already connected to the green wire of the **WHITE** harness)
6. Connect the wires of the **WHITE** harness as follows:
  - a. Green to DI1 (this is already connected to the green wire of the **BLACK** harness)
  - b. Yellow to DI2
  - c. Blue to DI
  - d. White to DI4
  - e. Brown to DI5

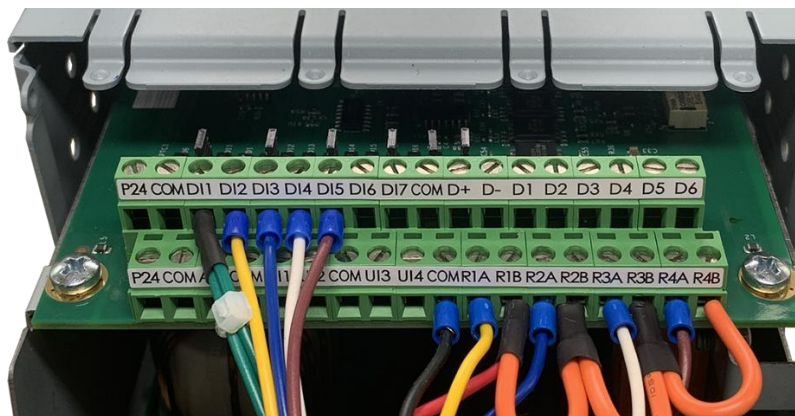

**Figure 3 Older SL120 Motor Controller Showing Existing Control Wiring**



**Caution:** To properly follow these instructions, you will need a belt tensioning tool that utilizes a spring depressor that reads in pounds and fractions of an inch.  
**Do not attempt to tension the belt without the proper testing tools.**  
**Failure to properly tension the belt may cause bearing failure or permanent damage to the motor.**

**Belts will loosen after running and warming up. Final adjustments should be made after 10 minutes of run time. If the existing belt shows signs of excessive wear, it should be replaced**

1. Measure the distance (inches) from the center shaft of the motor to the center shaft of the blower wheel.

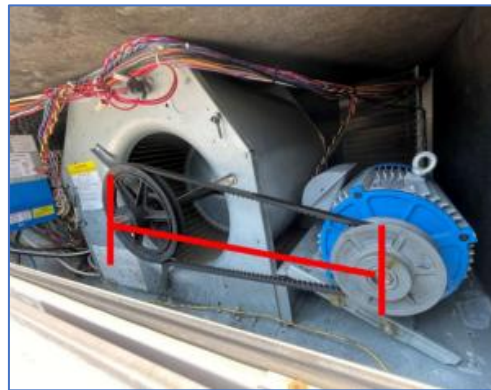

2. Round the distance to the closest value. If evenly divided, round down. *For example, 20 ½ is rounded down to 20 inches.*
3. Set the bottom O-ring of the belt tension gauge to that value. *For example, slide the O-ring down to the 20-inch mark or notch on your gauge.*

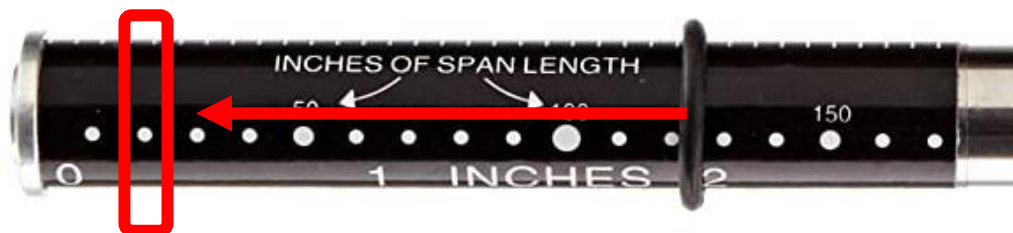

4. Set the top O-ring at zero (0). (Slide the O-ring to the base.)



5. Set a straight edge across the top of the belt. Deflect the belt until the bottom **O-ring** is in the same plane as the straight edge.

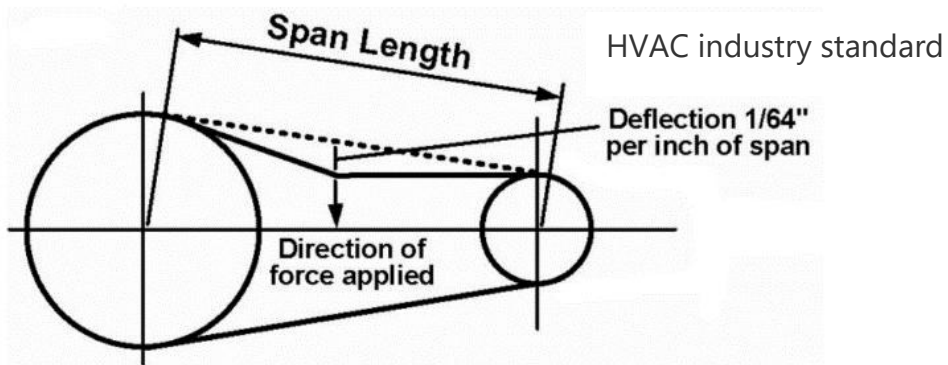
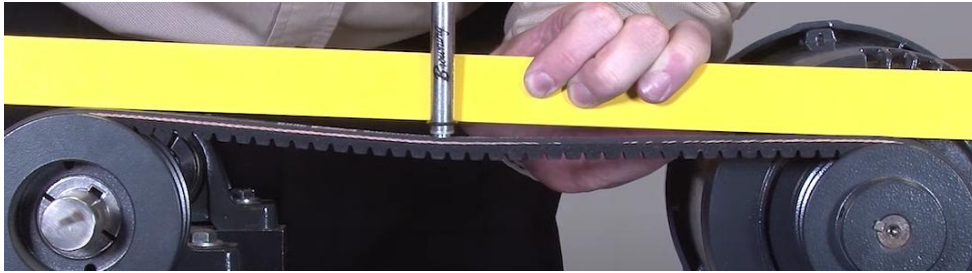

6. The top O-ring will have moved up the gauge and show the amount of force used. For example, say 7 pounds.
7. Measure the diameter of the smaller pulley. *The diameter of the smaller pulley determines pressure to the belt that should be applied to the belt.*



- Using a deflective force chart, find the value your tension gauge registered and compare it with the diameter of the smaller pulley.

*For example, if you are using a BX type belt, your tension gauge registered 10 pounds of force, and the smaller pulley is 5 inches in diameter, then the belt tension is in the acceptable range.*

	Smallest Pulley Diameter Range	RPM Range	Belt Deflection Setting			
			uncogged belts		cogged belts	
			used belt	new belt	used belt	new belt
4L, A, AX	2.0 - 2.9	1000 - 2500	1.8	2.6	2.0	3.0
		2501 - 4000	1.4	2.0	1.6	2.4
	3.0 - 3.6	1000 - 2500	3.6	5.4	4.0	6.0
		2501 - 4000	2.8	4.1	3.3	4.9
	3.8 - 4.8	1000 - 2500	4.4	6.6	4.9	7.3
		2501 - 4000	3.7	5.7	4.3	6.4
5.0 - 7.0	1000 - 2500	5.3	7.8	5.7	9.2	
	2501 - 4000	4.6	6.8	5.1	7.6	
5L, B, BX	3.4 - 4.2	860 - 2500			4.8	7.2
		2501 - 4000			4.1	6.2
	4.4 - 5.6	860 - 2500	5.2	7.9	7.1	10.5
		2501 - 4000	4.5	6.6	7.1	9.1
	5.8 - 8.6	860 - 2500	6.2	9.4	8.4	12.4
		2501 - 4000	6.0	6.8	7.3	10.7

If the belt cannot be properly tensioned, install a longer or shorter belt, as necessary.

## Fan Pulley and Motor Pulley Alignment

---

1. For proper belt-seating, ensure the centerline of the pulleys is aligned. Use a straight edge to verify pulley alignment.
2. Verify that all pulley setscrews are secure.

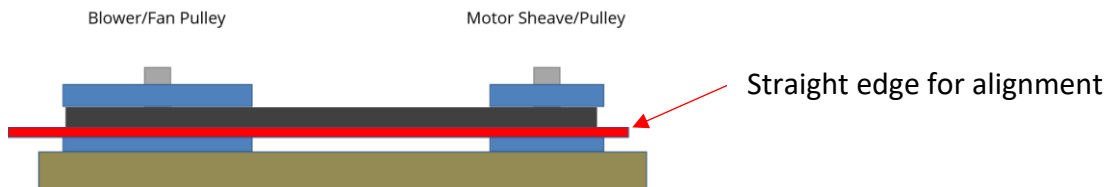

## Troubleshooting a Stalled Motor

---

### If motor stalling:

1. Remove the belt and test if the motor still stalls. (Manual mode in the Turntide Technician App.)
2. If motor runs *properly* without the belt:
  - **Slightly reduce the belt tension and test motor operation in small increments or upsize the belt if necessary.**
  - If you installed isolator feet, you may need to increase the belt by 2 sizes.
  - Note however, if the belt is too loose, it will slip and cause reduced airflow, excessive wear, and early failure.
3. If the motor is *still stalling* without a belt:
  - With the motor off, spin the motor by hand to feel bearings or if anything within the motor is clunking around.
  - Verify that power wiring is correctly wired. For example, are P2 & P3 correct or flipped?
  - Using the Turntide Technician App (**General** screen), verify that you have the correct motor model and voltage selected and that it matches the motor nameplate.
  - Confirm there aren't any rub-outs or exposed copper along the motor power wiring (Applicable check only if the motor has been in operation for some time).
  - If the motor continues to stall, contact Turntide Technical support. <http://support.turntide.com/>

**TURNTIDE TECHNOLOGIES**

Turntide Technologies | 11720 Amber Park Drive, Suite 160, Alpharetta, GA 30009 | [turntide.com](http://turntide.com) | [support@turntide.com](mailto:support@turntide.com)

