

Turntide V-Series Motors

Turntide V-Series Motor Product Family

Designed for HVAC Motor Upgrade / Retrofit



V01 (1-3 hp)





V02 (5 hp)



V03 (15 hp)

Turntide V-Series motors set the new standard for high efficiency in HVAC systems, exceeding IE5 efficient levels across most operating points, proving to be an excellent option for retrofitting your existing HVAC systems. Built with Turntide patented high rotor pole-switched reluctance motor (HR-SRM) topology, V-Series motors are engineered to replace inefficient motors found in legacy rooftop units (RTUs) and air handling units (AHUs), helping businesses run HVAC systems on significantly reduced energy, saving money while reducing carbon footprint.

Turntide V-Series Motors: Key Benefits

 <p>Optimally Efficient Across All Operating Points</p>	 <p>Fits into Existing HVAC System Standards</p>	 <p>Extends Lifespan of HVAC System</p>
<p>Reaches 94.7% peak motor efficiency (at 15hp), exceeding IE5-level efficiency standards</p>	<p>Built to industry dimension standards found in legacy motor technologies, such as NEMA and IEC frame sizes</p>	<p>Concentrated machine wound windings reduce losses and eliminates the potential for shorts, a common problem found in AC induction motors</p>

Other Benefits of Turntide V-Series Motors

- **Contains no rare earth magnets** typically designed into other high-efficiency motor technologies
- **Streamlined installation, commissioning, and performance monitoring** through the Turntide Technician mobile app

General Information (Same Across All Models)

Suitable HVAC Equipment for Motor Retrofit	Rooftop Units (RTUs), Air Handling Units (AHUs)
Product Name	V01 (up to 3 hp), V02 (up to 5 hp), V03 (up to 15hp)
Horsepower	1 - 15 hp
Voltage	208-230V, 400V, 460V, 575V
RPM Range	100 - 3600 RPM
Available Frame Sizes	56Y, 56/56H, 56Z / 56HZ / 143T / 145T, 182T/184T, 213T/215T
Motor Enclosure	TEFC
Supply Phase	3 - Phase
Ambient Temperature Range	-10°C to 40°C
Relative Humidity	95%, noncondensing
Insulation Class	F
Motor Ingress Protection	IP20

Detailed Technical Information

The following charts show technical specifications for our different specific motor models. For more information about proper motor selection, refer to the **Motor V Series Quick Reference Guide** at <https://support.turntide.com/>.

USA/Canada

Motor Model	Motor SKU	Rated HP / Power	Rated RPM	Operating RPM	Rated Service Factor	Peak Motor Efficiency	Peak System Efficiency	Rotor Inertia	Motor Frame Size	Motor Weight	Supply Voltage	Supply Frequency	Recommended Motor Controller SKU	Motor Controller Ingress Protection	Motor Controller Weight	Motor to Controller Power Wire
V01	V01-0300-2-D00	3 HP / 2.23 kW	1800 RPM	100-3600 RPM	1.15	92.2%	88.6%	0.1 lb-ft ² (0.0042 kg-m ²)	56Z/56HZ***/ 143T/145T	54 lb (24.5 kg)	208/230V~	60 Hz	SL121-2030A-RT^	IP20^	6.7 lb (3 kg)	14 AWG
V01	V01-0300-2-A00	3 HP / 2.23 kW	1800 RPM	100-3600 RPM	1.15	92.2%	88.6%	0.1 lb-ft ² (0.0042 kg-m ²)	56Y*	54 lb (24.5 kg)	208/230V~	60 Hz	SL121-2030A-RT^	IP20^	6.7 lb (3 kg)	14 AWG
V01	V01-0300-2-C00	3 HP / 2.23 kW	1800 RPM	100-3600 RPM	1.15	92.2%	88.6%	0.1 lb-ft ² (0.0042 kg-m ²)	56/56H**	54 lb (24.5 kg)	208/230V~	60 Hz	SL121-2030A-RT^	IP20^	6.7 lb (3 kg)	14 AWG
V01	V01-0300-2-F00	3 HP / 2.23 kW	1800 RPM	100-3600 RPM	1.15	92.2%	88.6%	0.1 lb-ft ² (0.0042 kg-m ²)	182T/184T	54 lb (24.5 kg)	208/230V~	60 Hz	SL121-2030A-RT^	IP20^	6.7 lb (3 kg)	14 AWG
V01	V01-0300-4-D00	3 HP / 2.23 kW	1800 RPM	100-3600 RPM	1.15	92.1%	90.2%	0.1 lb-ft ² (0.0042 kg-m ²)	56Z/56HZ***/ 143T/145T	54 lb (24.5 kg)	460V~	60 Hz	SL121-4030A-RT^	IP20^	6.7 lb (3 kg)	14 AWG
V01	V01-0300-4-A00	3 HP / 2.23 kW	1800 RPM	100-3600 RPM	1.15	92.1%	90.2%	0.1 lb-ft ² (0.0042 kg-m ²)	56Y*	54 lb (24.5 kg)	460V~	60 Hz	SL121-4030A-RT^	IP20^	6.7 lb (3 kg)	14 AWG
V01	V01-0300-4-C00	3 HP / 2.23 kW	1800 RPM	100-3600 RPM	1.15	92.1%	90.2%	0.1 lb-ft ² (0.0042 kg-m ²)	56/56H**	54 lb (24.5 kg)	460V~	60 Hz	SL121-4030A-RT^	IP20^	6.7 lb (3 kg)	14 AWG
V01	V01-0300-4-F00	3 HP / 2.23 kW	1800 RPM	100-3600 RPM	1.15	92.1%	90.2%	0.1 lb-ft ² (0.0042 kg-m ²)	182T/184T	54 lb (24.5 kg)	460V~	60 Hz	SL121-4030A-RT^	IP20^	6.7 lb (3 kg)	14 AWG
V01	V01-0300-6-D00	3 HP / 2.23 kW	1800 RPM	100-3600 RPM	1.15	92.2%	90.6%	0.1 lb-ft ² (0.0042 kg-m ²)	56Z/56HZ***/ 143T/145T	54 lb (24.5 kg)	575V~	60 Hz	P06C-0500-RT	IP65	11 lb (5 kg)	10-14 AWG
V01	V01-0300-6-A00	3 HP / 2.23 kW	1800 RPM	100-3600 RPM	1.15	92.2%	90.6%	0.1 lb-ft ² (0.0042 kg-m ²)	56Y*	54 lb (24.5 kg)	575V~	60 Hz	P06C-0500-RT	IP65	11 lb (5 kg)	10-14 AWG
V01	V01-0300-6-C00	3 HP / 2.23 kW	1800 RPM	100-3600 RPM	1.15	92.2%	90.6%	0.1 lb-ft ² (0.0042 kg-m ²)	56/56H**	54 lb (24.5 kg)	575V~	60 Hz	P06C-0500-RT	IP65	11 lb (5 kg)	10-14 AWG
V01	V01-0300-6-F00	3 HP / 2.23 kW	1800 RPM	100-3600 RPM	1.15	92.2%	90.6%	0.1 lb-ft ² (0.0042 kg-m ²)	182T/184T	54 lb (24.5 kg)	575V~	60 Hz	P06C-0500-RT	IP65	11 lb (5 kg)	10-14 AWG
V02	V02-0500-2-D00	5 HP / 3.72 kW	1800 RPM	100-3600 RPM	1.15	92.2%	88.9%	0.164 lb-ft ² (0.0068 kg-m ²)	56Z/56HZ***/ 143T/145T	72 lb (32.7 kg)	208/230V~	60 Hz	P06-0500-RT	IP65	11 lb (5 kg)	10-14 AWG
V02	V02-0500-2-F00	5 HP / 3.72 kW	1800 RPM	100-3600 RPM	1.15	92.2%	88.9%	0.164 lb-ft ² (0.0068 kg-m ²)	182T/184T	72 lb (32.7 kg)	208/230V~	60 Hz	P06-0500-RT	IP65	11 lb (5 kg)	10-14 AWG
V02	V02-0500-4-D00	5 HP / 3.72 kW	1800 RPM	100-3600 RPM	1.15	92.0%	90.0%	0.164 lb-ft ² (0.0068 kg-m ²)	56Z/56HZ***/ 143T/145T	72 lb (32.7 kg)	460V~	60 Hz	P06-0500-RT	IP65	11 lb (5 kg)	10-14 AWG
V02	V02-0500-4-F00	5 HP / 3.72 kW	1800 RPM	100-3600 RPM	1.15	92.0%	90.0%	0.164 lb-ft ² (0.0068 kg-m ²)	182T/184T	72 lb (32.7 kg)	460V~	60 Hz	P06-0500-RT	IP65	11 lb (5 kg)	10-14 AWG
V02	V02-0500-6-D00	5 HP / 3.72 kW	1800 RPM	100-3600 RPM	1.15	91.8%	89.4%	0.164 lb-ft ² (0.0068 kg-m ²)	56Z/56HZ***/ 143T/145T	72 lb (32.7 kg)	575V~	60 Hz	P06C-0500-RT	IP65	11 lb (5 kg)	10-14 AWG
V02	V02-0500-6-F00	5 HP / 3.72 kW	1800 RPM	100-3600 RPM	1.15	91.8%	89.4%	0.164 lb-ft ² (0.0068 kg-m ²)	182T/184T	72 lb (32.7 kg)	575V~	60 Hz	P06C-0500-RT	IP65	11 lb (5 kg)	10-14 AWG
V03	V03-1000-4-H00	10 HP / 7.46 kW	1800 RPM	100-3600 RPM	1.15	94.7%	93.2%	0.1 lb-ft ² (0.0042 kg-m ²)	213T/215T	151 lb (68.5 kg)	460V~	60 Hz	P06-1500-RT	IP65	11 lb (5 kg)	10-14 AWG
V03	V03-1000-6-H00	10 HP / 7.46 kW	1800 RPM	100-3600 RPM	1.15	94.7%	93.2%	0.1 lb-ft ² (0.0042 kg-m ²)	213T/215T	151 lb (68.5 kg)	575V~	60 Hz	P06C-1500-RT	IP65	11 lb (5 kg)	10-14 AWG
V03	V03-1500-4-H00	15 HP / 11.19 kW	1800 RPM	100-3600 RPM	1.15	94.7%	93.2%	0.1 lb-ft ² (0.0042 kg-m ²)	213T/215T	151 lb (68.5 kg)	460V~	60 Hz	P06-1500-RT	IP65	11 lb (5 kg)	10-14 AWG
V03	V03-1500-6-H00	15 HP / 11.19 kW	1800 RPM	100-3600 RPM	1.15	94.7%	93.2%	0.1 lb-ft ² (0.0042 kg-m ²)	213T/215T	151 lb (68.5 kg)	575V~	60 Hz	P06C-1500-RT	IP65	11 lb (5 kg)	10-14 AWG

IEC (Europe)

Motor Model	Motor SKU	Rated HP / Power	Rated RPM	Operating RPM	Rated Service Factor	Peak Motor Efficiency	Peak System Efficiency	Rotor Inertia	Motor Frame Size	Motor Weight	Supply Voltage	Supply Frequency	Recommended Motor Controller SKU	Motor Controller Ingress Protection	Motor Controller Weight	Motor to Controller Power Wire
V01	V01-0300-2-ID00	2.2 kW	1500 RPM	300-3000 RPM	1.15	90.9%	87.6%	0.1 lb-ft ² (0.0042 kg-m ²)	90S/90L	54 lb. (24.5 kg)	200V~	50 Hz	P06-0500-RT	IP65	11 lb (5 kg)	10-14 AWG
V01	V01-0300-2-IE00	2.2 kW	1500 RPM	300-3000 RPM	1.15	90.9%	87.6%	0.1 lb-ft ² (0.0042 kg-m ²)	100L	54 lb. (24.5 kg)	200V~	50 Hz	P06-0500-RT	IP65	11 lb (5 kg)	10-14 AWG
V01	V01-0300-2-IF00	2.2 kW	1500 RPM	300-3000 RPM	1.15	90.9%	87.6%	0.1 lb-ft ² (0.0042 kg-m ²)	112S	54 lb. (24.5 kg)	200V~	50 Hz	P06-0500-RT	IP65	11 lb (5 kg)	10-14 AWG
V01	V01-0300-4-ID00	2.2 kW	1500 RPM	300-3000 RPM	1.00	90.9%	88.9%	0.1 lb-ft ² (0.0042 kg-m ²)	90S/90L	54 lb. (24.5 kg)	400V~	50 Hz	P06-0500-RT	IP65	11 lb (5 kg)	10-14 AWG
V01	V01-0300-4-IE00	2.2 kW	1500 RPM	300-3000 RPM	1.00	90.9%	88.9%	0.1 lb-ft ² (0.0042 kg-m ²)	100L	54 lb. (24.5 kg)	400V~	50 Hz	P06-0500-RT	IP65	11 lb (5 kg)	10-14 AWG
V01	V01-0300-4-IF00	2.2 kW	1500 RPM	300-3000 RPM	1.00	90.9%	88.9%	0.1 lb-ft ² (0.0042 kg-m ²)	112S	54 lb. (24.5 kg)	400V~	50 Hz	P06-0500-RT	IP65	11 lb (5 kg)	10-14 AWG
V02	V02-0500-2-IG00	4 kW	1500 RPM	300 - 3000 RPM	1.00	91.8%	88.2%	0.164 lb-ft ² (0.0068 kg-m ²)	112M	72 lb. (32.7 kg)	200V~	50 Hz	P06-0500-RT	IP65	11 lb (5 kg)	10-14 AWG
V02	V02-0500-4-IG00	4 kW	1500 RPM	300- 3000 RPM	1.00	93.4%	91.6%	0.164 lb-ft ² (0.0068 kg-m ²)	112M	72 lb. (32.7 kg)	400V~	50 Hz	P06-0500-RT	IP65	11 lb (5 kg)	10-14 AWG
V03	V03-0750-4-IH00	5.5 kW	1500 RPM	300 - 3000 RPM	1.15	94.5%	92.6%	0.1 lb-ft ² (0.0042 kg-m ²)	132S	151 lb (68.5 kg)	400V~	50 Hz	P06-1500-RT	IP65	11 lb (5 kg)	10-14 AWG
V03	V03-1000-4-醜維00	7.46 kW	1500 RPM	300 - 3000 RPM	1.15	94.5%	92.6%	0.1 lb-ft ² (0.0042 kg-m ²)	132M	151 lb (68.5 kg)	400V~	50 Hz	P06-1500-RT	IP65	11 lb (5 kg)	10-14 AWG

Notes:

*56Y frame motors are not all the same dimensions. If the existing motor is 56Y, make sure to check that it matches with the Turntide motor.

**A shaft diameter of 5/8" = NC, if 7/8" = ND. 56/56H motors typically have a 5/8" shaft diameter but are not all the same dimensions. Make sure to check that shaft diameter, shaft height, shaft length, and bolt hole positioning match the Turntide motor.

***A shaft diameter of 5/8" = NC, if 7/8" = ND. 56Z/56HZ motors typically have a 7/8" shaft diameter but are not all the same dimensions. Make sure to check that shaft diameter, shaft height, shaft length, and bolt hole positioning match the Turntide motor.

^If the motor controller requires protection above IP20, use P06-0500-RT motor controller SKU instead. The motor controller will have IP65 ingress protection.

For other technical specifications not covered in the document, please reach out directly to Turntide at support@turntide.com for further information.

Motor System Efficiency Curves

Notes:

1. These efficiency curves depict motor system efficiency versus torque, meaning it covers the Turntide smart motor paired with its compatible Turntide motor controller.
2. Not all possible motor performance options are shown in these curves.

V01 USA / Canada

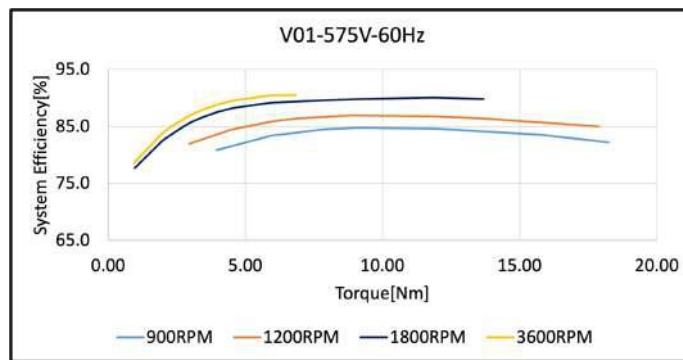
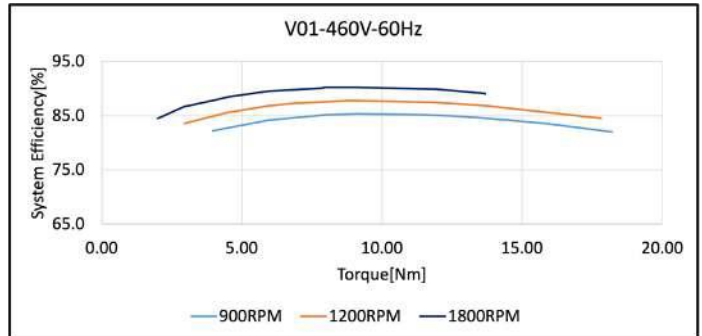
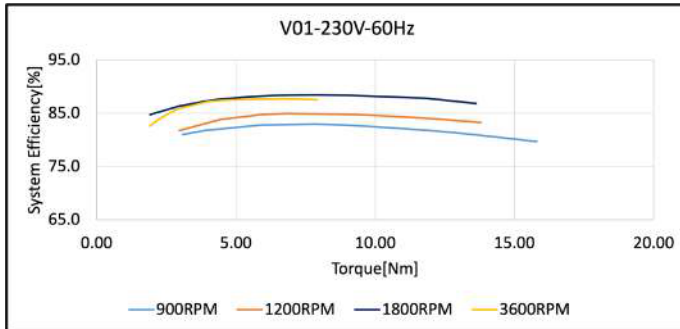

V01 Europe (IEC)

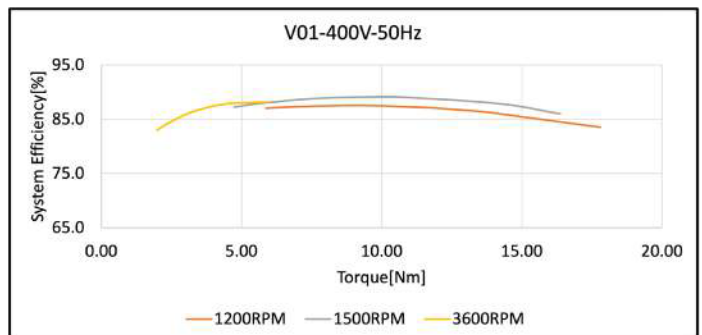
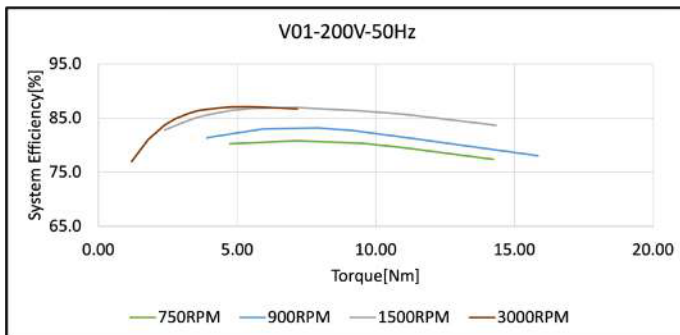

V02 USA / Canada

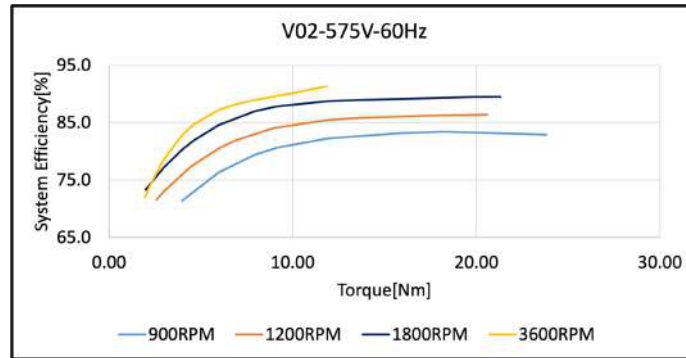
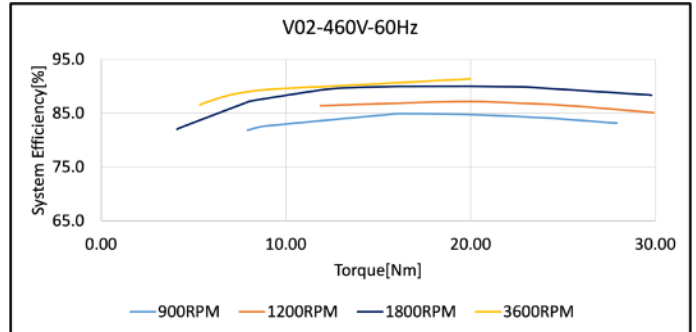
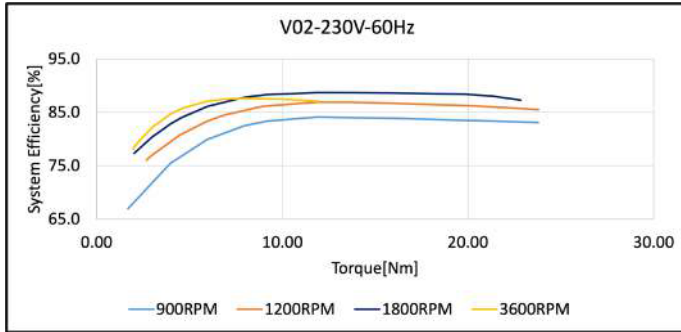

V02 Europe (IEC)

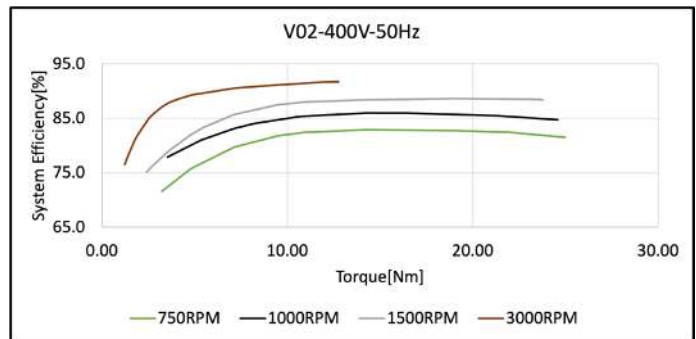
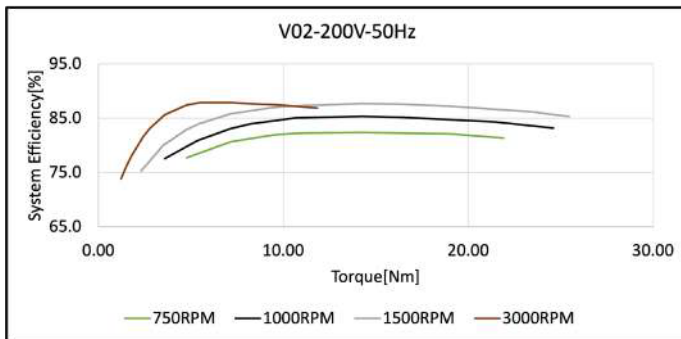

V03 USA / Canada

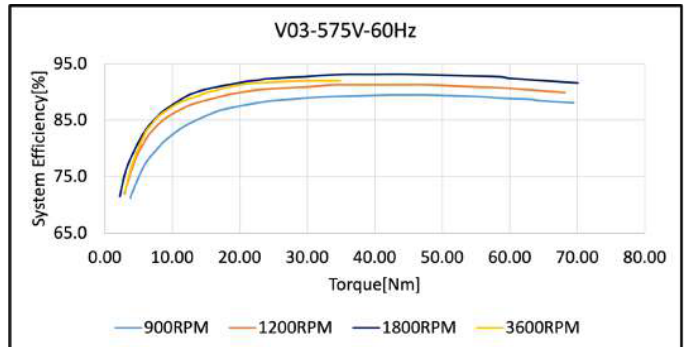
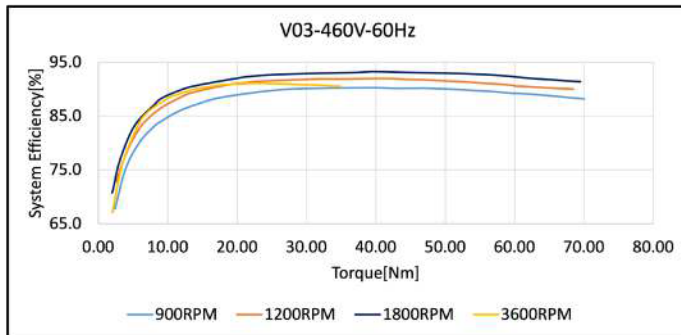

V03 Europe (IEC)

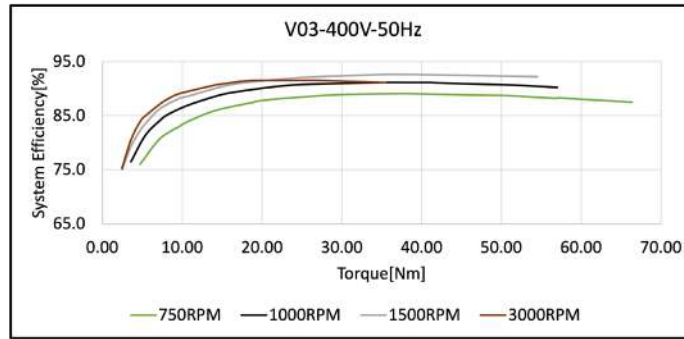

V-Series Motor Torque-Speed Curve

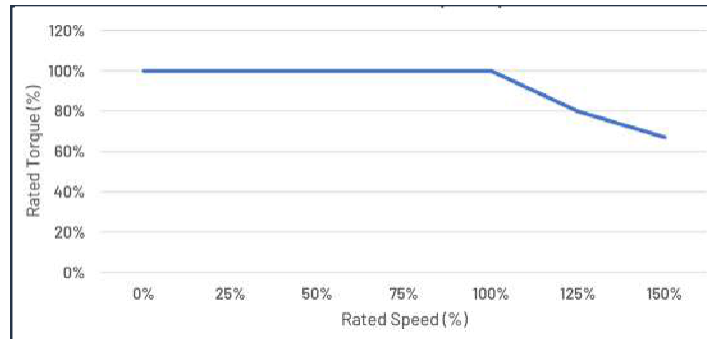

Certifications



UL: 1004-7

CSA: C22.2#77

IEC: 60034-1, 60204-1

Table I. NEMA Motors

Agency	Code	Description
CSA	C22.2 No.77	Motors with inherent overheating protection
CSA	C22.2 No. 100	Motors and generators
UL	1004-7	Electronically protected motors
UL	1004-8	Inverter Duty Motors
ETL-Intertek		Marking
RoHS		Restriction of Hazardous Substances Directive
Agency	Code	Description
IEC	60204-1	Safety of machinery - Electrical equipment of machines - Part 1: General Requirement
IEC	60034-1	Rotating electrical machines - Part 1: Rating and performance
CE		Marking
RoHS		Restriction of Hazardous Substances Directive

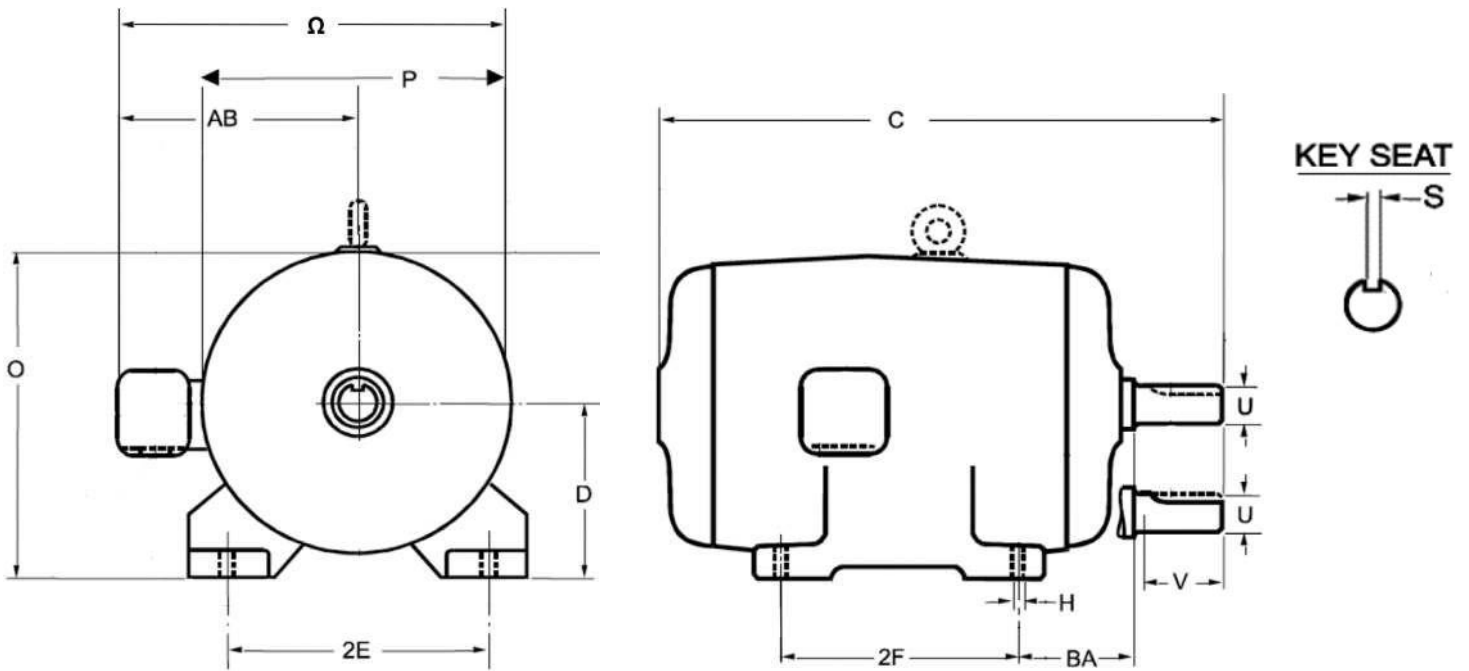
Motor Dimensions (Fractions) all dimensions are in inches

Motor	Frame Size	D**		O**		2E	2F	H	BA	U	V	C	P	S	AB	Ω***
		Standard Foot	N.I. Foot	Standard Foot	N.I. Foot											
V01	56	3-1/2	4	7-5/16	7-13/16	4-7/8	3	11/32	2-3/4	5/8	1-7/8	12-1/4	7-11/16	3/16	6-1/2	10-3/8
	56Y*	3-1/2	4	7-5/16	7-13/16	4-7/8	3	11/32	2-3/4	5/8	4-1/2	14-5/6	7-11/16	3/16	6-1/2	10-3/8
	56H*	3-1/2	4	7-5/16	7-13/16	4-7/8	5	11/32	2-3/4	5/8	1-7/8	12-1/4	7-11/16	3/16	6-1/2	10-3/8
	56HZ	3-1/2	4	7-5/16	7-13/16	4-7/8	5	11/32	2-3/4	7/8	2-1/4	12-5/8	7-11/16	3/16	6-1/2	10-3/8
	143T	3-1/2	4	7-5/16	7-13/16	5-1/2	4	11/32	2-3/4	7/8	2-1/4	12-5/8	7-11/16	3/16	6-1/2	10-3/8
	145T	3-1/2	4	7-5/16	7-13/16	5-1/2	5	11/32	2-3/4	7/8	2-1/4	12-5/8	7-11/16	3/16	6-1/2	10-3/8
	182T	4-1/2	5	7-5/16	7-13/16	7-1/2	4-1/2	11/32	2-3/4	1 1/8	2-3/4	12-7/8	7-11/16	3/16	6-1/2	10-3/8
	184T	4-1/2	5	7-5/16	7-13/16	7-1/2	5-1/2	11/32	2-3/4	1 1/8	2-3/4	12-7/8	7-11/16	3/16	6-1/2	10-3/8
V02	143T	3-1/2	3-5/7	8-5/16	8-51/100	5-1/2	4	11/32	2-1/4	7/8	2-1/4	15-1/2	7-11/16	1/4	6-1/2	10-3/8
	145T	3-1/2	3-5/7	8-5/16	8-51/100	5-1/2	5	11/32	2-1/4	7/8	2-1/4	15-1/2	7-11/16	1/4	6-1/2	10-3/8
	182T	4-1/2	4-5/7	8-5/16	8-51/100	7-1/2	4-1/2	11/32	2-3/4	1-1/8	2-3/4	15-3/4	7-11/16	1/4	6-1/2	10-3/8
	184T	4-1/2	4-5/7	8-5/16	8-51/100	7-1/2	5-1/2	11/32	2-3/4	1-1/8	2-3/4	15-3/4	7-11/16	1/4	6-1/2	10-3/8
V03	213T	5-1/4	5-85/100	11-1/2	12-1/10	8-1/2	5-1/2	13/32	3-1/2	1-3/8	3-1/2	17-7/16	11-11/16	5/16	8-3/16	14-3/8
	215T	5-1/4	5-85/100	11-1/2	12-1/10	8-1/2	7	13/32	3-1/2	1-3/8	3-1/2	17-7/16	11-11/16	5/16	8-3/16	14-3/8

Note: N.I. Foot stands for noise isolation feet

*56Y and 56H frame motors are not all the same. If the existing motor is 56Y or 56H, make sure to check it matches with the Turntide motor.

**Motors with noise isolation feet attached will have different "D" and "O" dimensions

***Not a NEMA reference

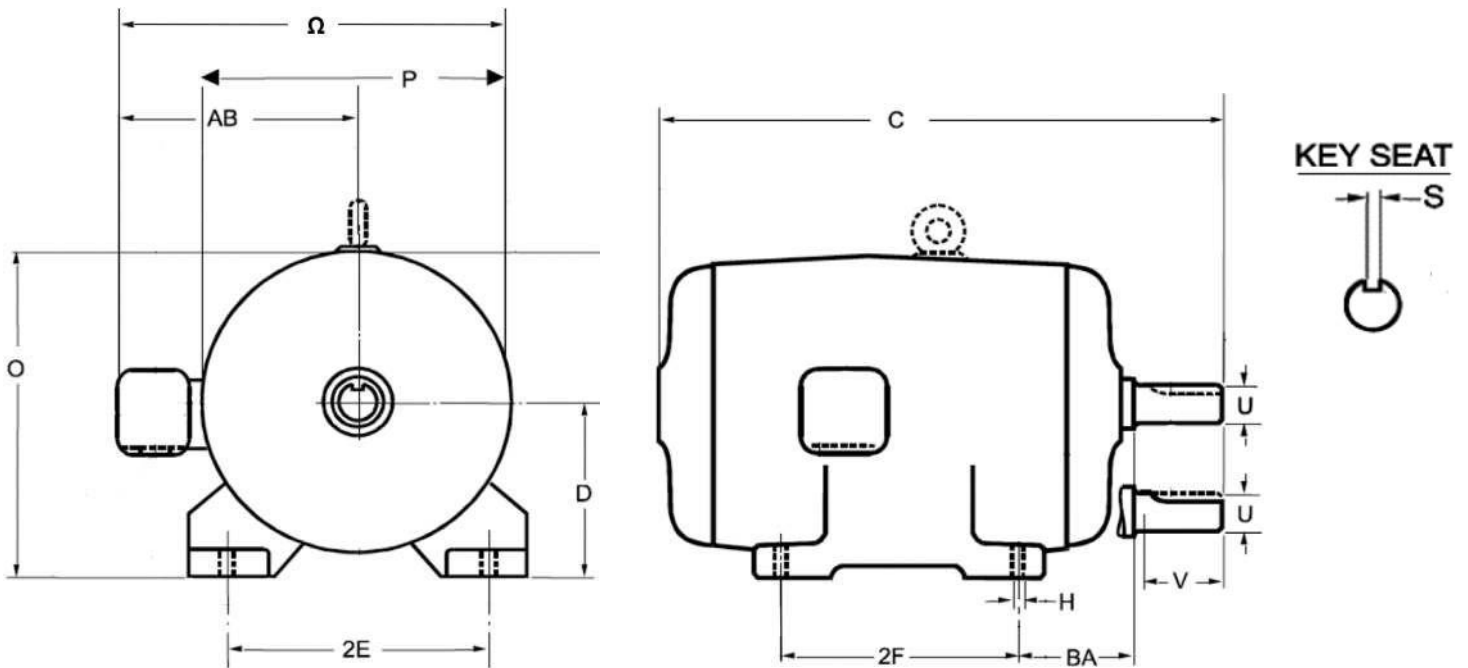
Motor Dimensions (Decimals) all dimensions are in inches

Motor	Frame Size	D**		O**		2E	2F	H	BA	U	V	C	P	S	AB	Ω***
		Standard Foot	N.I. Foot	Standard Foot	N.I. Foot											
V01	56	3.50	4.00	7.31	7.81	4.88	3.00	0.34	2.75	0.6250	1.88	12.25	7.69	0.188	6.50	10.38
	56Y*	3.50	4.00	7.31	7.81	4.88	3.00	0.34	2.75	0.6250	4.50	14.83	7.69	0.188	6.50	10.38
	56H*	3.50	4.00	7.31	7.81	4.88	5.00	0.34	2.75	0.6250	1.88	12.25	7.69	0.188	6.50	10.38
	56HZ	3.50	4.00	7.31	7.81	4.88	5.00	0.34	2.75	0.8750	2.25	12.63	7.69	0.188	6.50	10.38
	143T	3.50	4.00	7.31	7.81	5.50	4.00	0.34	2.75	0.8750	2.25	12.63	7.69	0.188	6.50	10.38
	145T	3.50	4.00	7.31	7.81	5.50	5.00	0.34	2.75	0.8750	2.25	12.63	7.69	0.188	6.50	10.38
	182T	4.50	5.00	7.31	7.81	7.50	4.50	0.34	2.75	1.1250	2.75	12.88	7.69	0.188	6.50	10.38
	184T	4.50	5.00	7.31	7.81	7.50	5.50	0.34	2.75	1.1250	2.75	12.88	7.69	0.188	6.50	10.38
V02	143T	3.50	3.70	8.31	8.51	5.50	4.00	3.67	2.25	0.8750	2.25	15.50	7.69	0.250	6.50	10.38
	145T	3.50	3.70	8.31	8.51	5.50	5.00	3.67	2.25	0.8750	2.25	15.50	7.69	0.250	6.50	10.38
	182T	4.50	4.70	8.31	8.51	7.50	4.50	3.67	2.75	1.1250	2.75	15.75	7.69	0.250	6.50	10.38
	184T	4.50	4.70	8.31	8.51	7.50	5.50	3.67	2.75	1.1250	2.75	15.75	7.69	0.250	6.50	10.38
V03	213T	5.25	8.85	1.50	12.10	8.50	5.50	0.41	3.50	1.3750	3.50	17.44	11.69	0.313	8.19	14.38
	215T	5.25	8.85	1.50	12.10	8.50	7.00	0.41	3.50	1.3750	3.50	17.44	11.69	0.313	8.19	14.38

Note: N.I. Foot stands for noise isolation feet

*56Y and 56H frame motors are not all the same. If the existing motor is 56Y or 56H, make sure to check it matches with the Turntide motor.

**Motors with noise isolation feet attached will have different "D" and "O" dimensions

***Not a NEMA reference

Motor Controller Dimensions

P06 Motor Controller

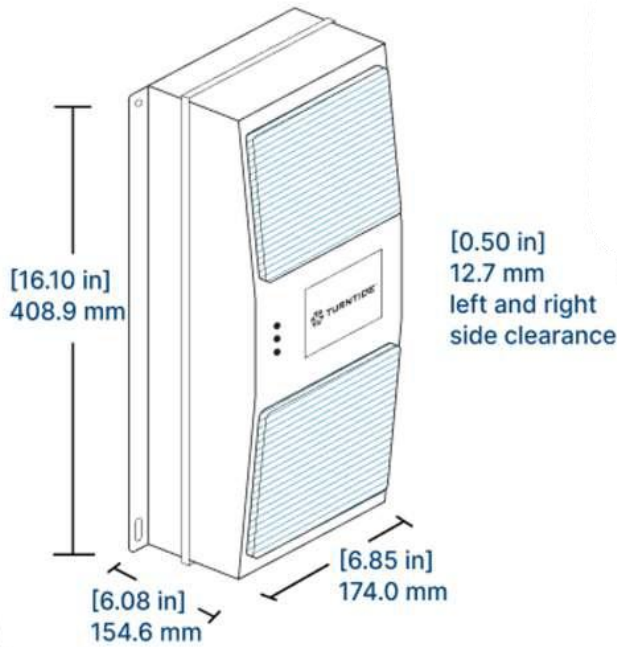

SL121 Motor Controller

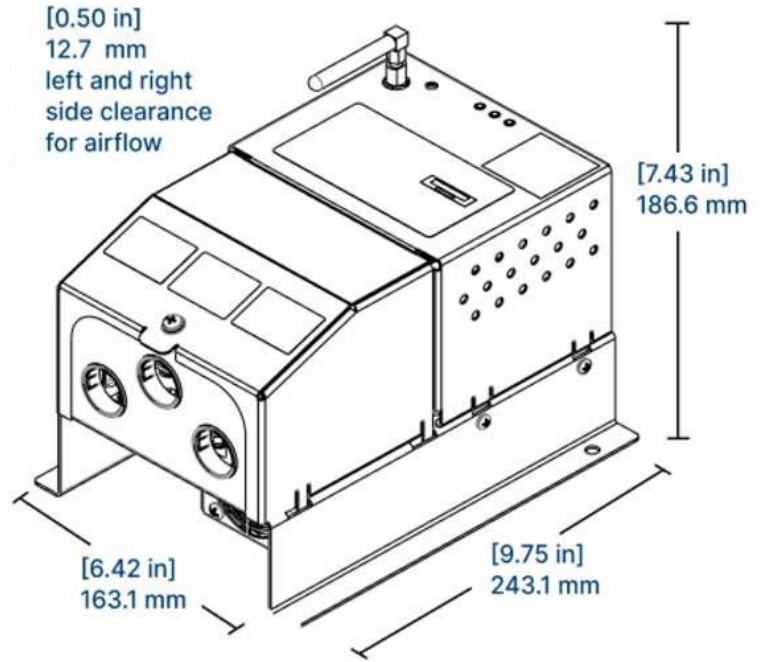

Questions?



If you have any specific questions about Turntide motors not answered in this document, please contact support@turntide.com for more information.

TURNTIDE TECHNOLOGIES

Turntide Technologies | 11720 Amber Park Drive, Suite 160, Alpharetta, GA 30009 | turntide.com | support@turntide.com