



Technical Reference Guide
P06 Motor Controller
Turntide Smart Motor Systems

Document Version 2.0
December 3, 2025





Revision History

Document Revision Number	Description	Date												
1.0	Initial Release in this format	February 6, 2023												
1.1	Documentation correction ONLY: SW7 switches, see User-Selectable Switch Options Diagram .	February 9, 2023												
1.2	Document revision: The LEDs have the following characteristics: On, Off, Flashing (Slow 0.4s, Fast 0.1s), Flicker . The – (dash) in the following table is equivalent to <i>not applicable</i> , meaning its characteristic has no impact on the how you interpret the state. See LED Indicators .	February 15, 2023												
1.3	Added table comparing control connections for all Turntide controllers. See Control Connections . <table border="1" data-bbox="316 934 1140 1203"> <thead> <tr> <th>Controller</th> <th>Connections</th> <th>Labeling in unit</th> </tr> </thead> <tbody> <tr> <td>P04 and P05 controllers</td> <td>UI1-UI4 are NOT isolated and all four are referenced to GND.</td> <td>GND is labeled as AC and COM is labeled as SC.</td> </tr> <tr> <td>SL120 controller</td> <td>UI1-UI4 are ALL isolated and ALL are referenced to COM.</td> <td>Labeled as COM in the controller.</td> </tr> <tr> <td>P06 and SL121 controllers</td> <td>Only the UI4 is isolated and referenced to COM. UI1-UI3 are referenced to GND.</td> <td>Labeled as COM and GND in the controllers.</td> </tr> </tbody> </table>	Controller	Connections	Labeling in unit	P04 and P05 controllers	UI1-UI4 are NOT isolated and all four are referenced to GND.	GND is labeled as AC and COM is labeled as SC .	SL120 controller	UI1-UI4 are ALL isolated and ALL are referenced to COM.	Labeled as COM in the controller.	P06 and SL121 controllers	Only the UI4 is isolated and referenced to COM. UI1-UI3 are referenced to GND.	Labeled as COM and GND in the controllers.	February 17, 2023
Controller	Connections	Labeling in unit												
P04 and P05 controllers	UI1-UI4 are NOT isolated and all four are referenced to GND.	GND is labeled as AC and COM is labeled as SC .												
SL120 controller	UI1-UI4 are ALL isolated and ALL are referenced to COM.	Labeled as COM in the controller.												
P06 and SL121 controllers	Only the UI4 is isolated and referenced to COM. UI1-UI3 are referenced to GND.	Labeled as COM and GND in the controllers.												
1.4	Added air flow information and revised controller orientation in installation. See Installation Orientation and Airflow .	February 23, 2023												
1.5	Correction to Wi-Fi frequency range: Note: If you intend to install a Turntide Remote Monitoring Kit (RMK), the P06 motor controller must be mounted within a 40ft radius of the RMK or a 250ft radius of the RMK-LR networking device to ensure a stable and reliable connection to Wi-Fi. See Table 3 Motor Controller Model Information .	February 24, 2023												
1.6	Correction: Controller and motor pairings includes 10HP for P06. See Table 1 Controller and Motor Pairing . Added: Image of controller to cover	February 28, 2023												

1.7	<p>Improved: P06 with DIP Switch image. See User-Selectable Switch Options .</p> <p>Correction to certification pending. See Safety Standards.</p> <p>Revised note. Now “Mount the controller in an upright (vertical), sideways (horizontal), or flat position to/on a rigid surface. See Installation Orientation and Airflow.</p>	March 14, 2023
1.8	<p>Added:</p> <ul style="list-style-type: none"> • “Never wire digital inputs to a contactor coil without isolation such as an interposing relay or using available auxiliary contacts. <i>If you do not isolate the inputs, inductive kickback can damage the device.</i>” See Digital Input Connections. • How to Replace a P04/P05/SL120 with SL121/P06 Control Wiring <p>Removed:</p> <ul style="list-style-type: none"> • Prerequisite. Now technician is NO longer required to take Turntide training course. • Instructions for P06 and SL121 manual Wi-Fi disconnect. Technicians must call Turntide Technical Services instead. <p>Clarified: Introduction on Control Wiring Methods.</p>	May 26, 2023
2.0	<p>Removed</p> <ul style="list-style-type: none"> • Reference to cloud and Turntide Academy • Direct links to additional guides. Replaced with main support site • RMK product <p>Updated</p> <ul style="list-style-type: none"> • Safety Standards • Electrical Characteristics • Ratings <p>Added</p> <ul style="list-style-type: none"> • P06 Motor Controller User-Selectable Switch Options Diagram 	December 3, 2025

Conventions

Bold	<ul style="list-style-type: none"> • Used in procedures for names of interface elements, such as buttons, fields, and menu items. • For names of apps. • For emphasis, typically when introducing a new concept or for the adverb “not.” • For measurements when necessary to distinguish from surrounding text
<i>Italics</i>	References to names of additional Turntide guides and documents.
Links	Blue font for cross-references within document and to external sources.
Note:	Indicates information that can help a customer make better use of a Turntide product.
Caution icon 	Indicates an instruction that draws attention to the risk of damage to the product, process, or surroundings.
Warning icon 	Indicates an instruction that draws attention to risk of injury or death and tells the customer how to avoid the potential problem.

Legal

The information in this document is subject to change without notice and should not be construed as a commitment by Turntide Technologies® (f/k/a Software Motor Company). Turntide Technologies assumes no responsibility for any errors that may appear in this document and provides the information contained in this document “as is” and without warranty of any kind whatsoever. To the maximum extent permitted by law, in no event shall Turntide Technologies be liable for indirect, incidental, or consequential damages arising from use of this document or the software and/or hardware described in this document. © Turntide Technologies. All rights reserved.

Contact

support@turntide.com | 11720 Amber Park Drive, Suite 160, Alpharetta, GA 30009 | www.turntide.com

Contents

Audience	6
Reference	6
Introduction	7
P06 Motor Controller Summary	7
Inputs/Outputs List	7
Turntide Motor Controller and Motor Pairings	8
Motor Controller Model and System Characteristics	9
P06 Motor Controller Dimensions	11
Installation Orientation and Airflow	13
Safety	14
Precautions	14
Handling	14
Safety Standards	14
UL and CSA Standards	15
IEC	15
Overall System Standards	15
Conformance	15
Control Wiring Methods	16
Motor Controller to Turntide Smart Motor Cabling	18
Power Cabling to Motor Controller	18
Overview of Motor Controller Installation Instructions	19
Mounting Guidelines	19
Wiring	20
P06 Specific Guidelines	20
Monitor Only	21
Operation	22
Initial Operation Checkout	22
Maintenance	23
General Inspection	23
Functional Operation	23
Power Input	23

	Audience
EMI/EMC Filter	23
Soft Start	23
Brownout	24
DC Bus Discharge	24
Power Stage	24
DSP Controller	24
Motor Controller Configuration Settings	25
Digital Input Program Options	28
Sensors	28
Phase current (IPH)	28
DC bus voltage (DC_BUS_VOLTAGE)	28
Motor and Motor Controller Protection	29
Faults and Error Conditions	29
Locked Rotor Detect	30
Over Voltage and Under Voltage Limit	30
Over Speed Limit	30
Enclosure Temperature Monitor	30
Heatsink Temperature Monitor	30
Peripheral Functions	31
LED Indicators	31
Modbus Interface	32
Wi-Fi Interface	33
External Fan	33
Grounding	34
Grounding Lugs	34
Safety Requirements	34
Connections	35
Power Connections	35
Control Connections	36
Definitions	36
Auxiliary Power Output	37
Digital Input Connections	37

	Audience
Modbus Connection	37
Analog Output Connection	38
Universal Analog Inputs	38
Switch Options	39
SW7 for Modbus Termination Resistor and Digital Input Mode	39
User-Selectable Switch Options Image	40
P06 Motor Controller User-Selectable Switch Options Diagram	41
User-Selectable Switch Options Usage & Examples	42
Motor Controller Interface Options	44
Specifications	44
Operation Conditions	44
Electrical Characteristics	44
Mechanical	44
Input/Output	45
Wire Gauge and Torque	45
Ratings	46
P06 Block Diagram	46
Appendix	47
Turntide Windows PC Control App (SMCUI)	47
Connecting to the Motor Controller over Modbus	47
Connecting to the Motor Controller Over Wi-Fi	50
Method 1: Connecting to the motor controller's Access Point	50
Method 2: Connecting to a Wireless Network	51
Motor Controller Drive Details	52
Upgrading the Motor Controller Firmware	54
Running the Motor through the Windows PC Control Application	55
Programming Options - 0-10Vdc, 0-20mA, 4-20mA	56
How to Replace a P04/P05/SL120 with SL121/P06 Control Wiring	57

Audience

The instructions in this guide are intended for a mechanical technician who is familiar working with commercial HVAC systems such as rooftop units (RTUs), air handling units (AHUs), and other similar equipment.

You will have access to Support from Turntide Technical Services: support@turntide.com



Required: Follow all local and national electrical codes, safety compliance requirements, and common installation procedures.

Reference

Reference material and additional instructions on <https://support.turntide.com/>

Introduction

The Turntide® motor system consists of a switched reluctance motor and requires an electronic motor controller to operate it. The motor controller is proprietary to Turntide and contains unique circuitry required to control a switch reluctance motor along with proprietary control methodology and information.



Commercially available motor controllers and variable frequency drives **will not operate** the Turntide motor. Turntide motor controllers **cannot operate** non-Turntide commercially available motors/motor products. This may result in malfunction or damage to the motor or controller.

P06 Motor Controller Summary

The P06 motor controller is engineered for stable and continuous performance of the Turntide optimal efficiency V-series motors.

- Supports horsepower ranges up to **15HP** motor operation
- High bus capacitance for safe thermal performance during motor operation
- Two +24VDC power outputs for connecting sensors to monitor operating conditions
- Easy-to-access I/O terminals to simplify system installation
- Plenum rated (UL 60335-2-40 certified) to ensure product safety in harsh operating environments
- Programmable inputs and outputs using Turntide proprietary Cascade configuration software platform to allow for ultimate customization of sequences and settings

Inputs/Outputs List

- **7** programmable digital inputs
- **1** programmable analog output: 0-10V, 0-20mA or 4-20mA, user selectable
- **4** relay outputs: 0.3A, 125VAC limit
- **4** universal inputs, individually selectable as:
 - Voltage mode: 0-10V
 - Current mode: 0-20mA or 4-20mA
 - Resistive mode
 - External logic mode
- **1** 24VDC Aux power outputs (up to 250mA)



Turntide Motor Controller and Motor Pairings

Currently, configurations between the Turntide P06 motor controller and **Turntide V-series motors** are supported. For other potential motor pairings, consult Turntide Technical Support.

Table 1 Controller and Motor Pairing

Turntide Smart Motor Product Line	Max Horsepower	Voltage Rating	Turntide Smart Motor SKU	Motor Controller SKU						
				SL121-2030	SL121-4030	P06-0500	P06C-0500	P06-1500	P06C-1500	P06-SL
V-Series for General Purpose	3 HP	208/230V	V01-0300-2	✓		✓				
		460V	V01-0300-4		✓	✓				
		575V	V01-0300-6				✓			
	5 HP	208/230V	V02-0500-2			✓		✓		
		460V	V02-0500-4			✓		✓		
		575V	V02-0500-6				✓		✓	
	10 HP	460V	V03-1000-4					✓		
		575V	V03-1000-6						✓	
	15 HP	460V	V03-1500-4					✓		
		575V	V03-1500-6						✓	
V-Series for Agriculture	1.5 HP	280-565V	V01-0150-4S-D00							✓
	3 HP	460V	V03-0300-4S-H00							✓
TX-Series for General Purpose	3.3 HP	208/230V	T01-0330-2-T06-AV							✓
		460V	T01-0330-4-T06-AV							✓
	7.25 HP	460V	T02-0725-4					✓		
		575V	T02-0725-6						✓	

Table 2 SKU and Motor Pairing

SKU	Description
P06-1500-RT	15 HP Turntide P06 Smart Motor Controller, 400-460V, RTU Prewired
P06-0500-RT	5 HP Turntide P06 Smart Motor Controller, 400-460V, RTU Prewired
P06-1500-AA	15 HP Turntide P06 Smart Motor Controller, 400-460V
P06C-1500-RT	15 HP Turntide P06 Smart Motor Controller, 575V, RTU Prewired
P06C-0500-RT	5 HP Turntide P06 Smart Motor Controller, 575V, RTU Prewired

Motor Controller Model and System Characteristics

Table 3 Motor Controller Model Information

Item	Description
Motor Controller Model	P06
Ingress protection code	IP65
Motor to controller power wire	10-14 AWG
Ambient temperature range	-10°C to +40°C
Relative humidity	95%, non-condensing
Maximum installation altitude with derate	1 km
Wi-Fi frequency range	2.4 GHz ~ 2.5 GHz (single band)
Wi-Fi interface	802.11 b/g/n (802.11n up to 150 Mbps)

Table 4 Motor System Characteristics

Motor System Characteristics	Description
Compatible Turntide motor series	V01/V02/V03/T01/T02
Max output power range	1-15HP (0.75 - 11.2 kW)
Peak motor controller efficiency	98.0%
Mounting hole pattern	363.0mm x 174.0mm
Mounting fastener	¼ inch or M7 Mounting: Securely install the motor controller to a solid mounting surface with a ¼ inch or M7 fastener using the four screw tabs on the base.
Motor controller weight	11.0lb (5.0kg)
Minimum firmware version	2.7

Table 5 P06 Motor Controller: Operating Characteristics

P06 Motor Controller: Operating Characteristics					
SKU	Input Line Voltage	Input Frequency	Input Line Current	Motor	Rated Output Voltage
P06-1500-AA/RT P06-0500-RT P06-SL	3 PH 208/230V~	60 Hz	11-16A (@208 V~)	V01 <u>or</u> V02	3PH 295 V== (@208 V~)
			9.5-14A (@230 V~)		3PH 340 V== (@230 V~)
	3 PH 460V~	60 Hz	5A	V01	3PH 680 V== (@460 V~)
			5.5A	T01	
			9.5A	V02	
			18A	V03	
	3 PH 200/230V~	50 Hz	11.3-18A (@200 V~)	V01 <u>or</u> V02	3PH 280 V== (@200 V~)
			10-14A (@230 V~)		3PH 340 V== (@230 V~)
	3 PH 400V~	50 Hz	6A	V01	3PH 590 V== (@400 V~)
			2.5 kW - 4.3 Arms*	T01	
			4 kW - 7.9 Arms*	V02	
			11 kW - 20 Arms*	V03	
P06C-1500-RT P06C-0500-RT	3PH 575 V~	60 Hz	8.5A	V02	3PH 850 V== (@575 V~)
			16A	V03	

* Estimated input AC phase currents

P06 Motor Controller Dimensions

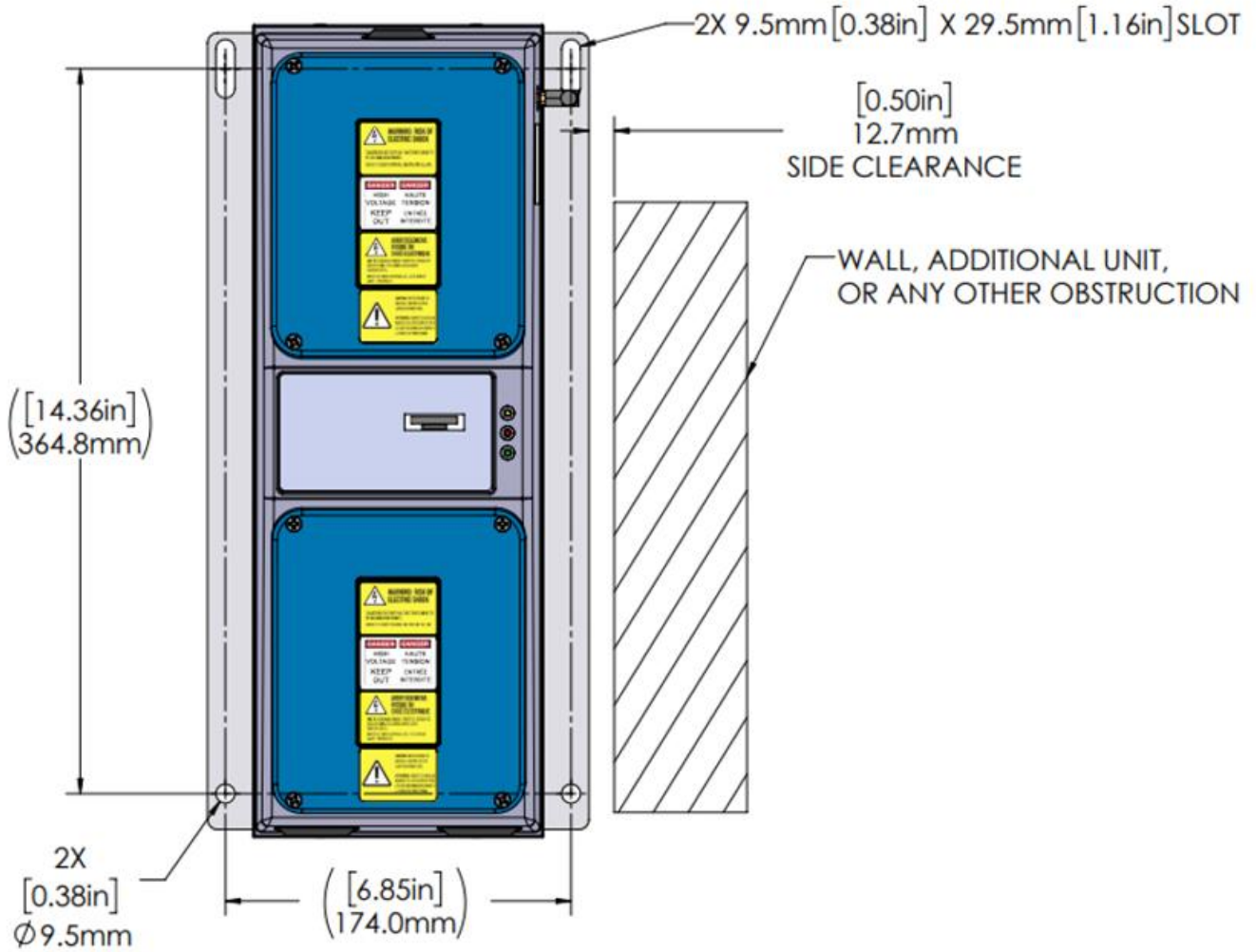
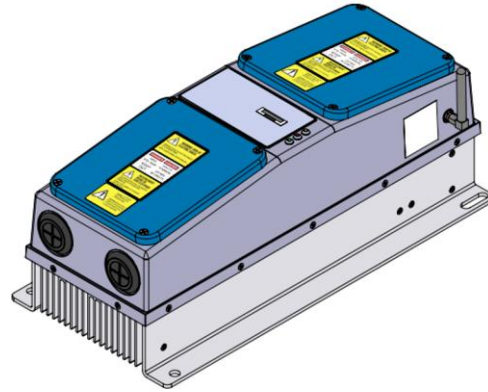

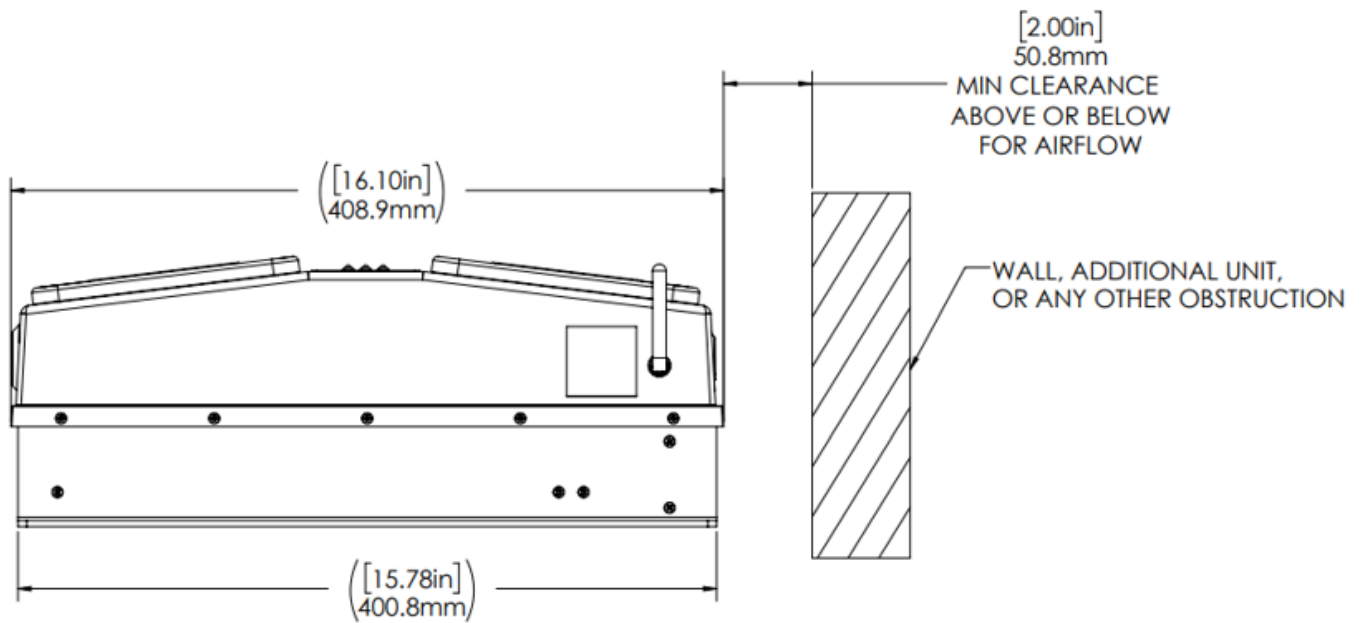
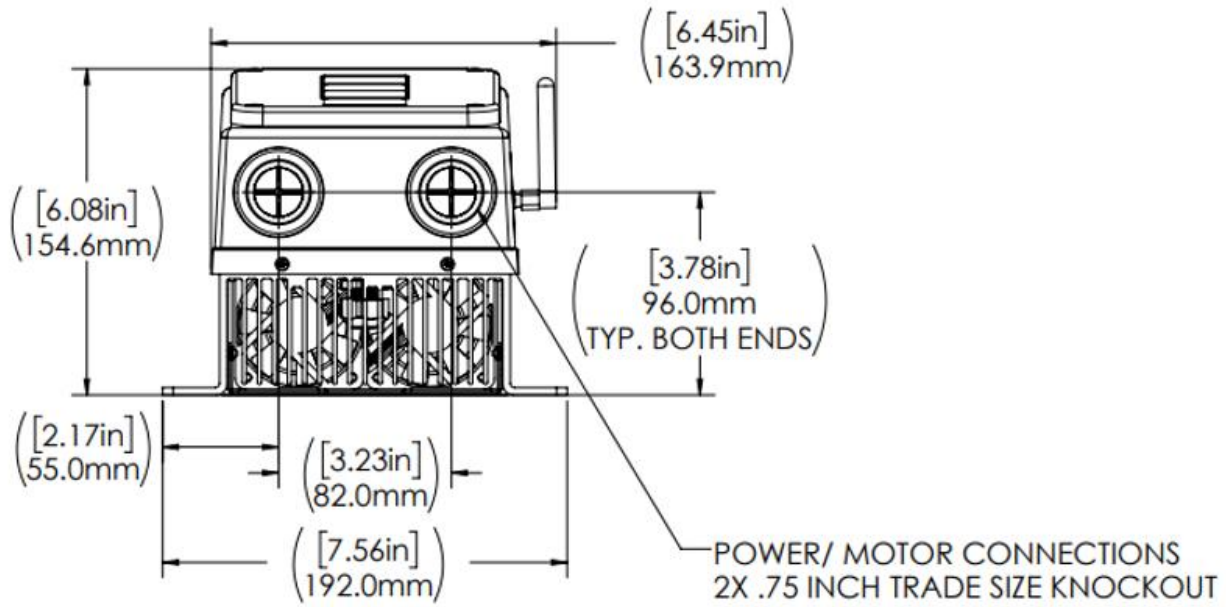

Installation Orientation and Airflow

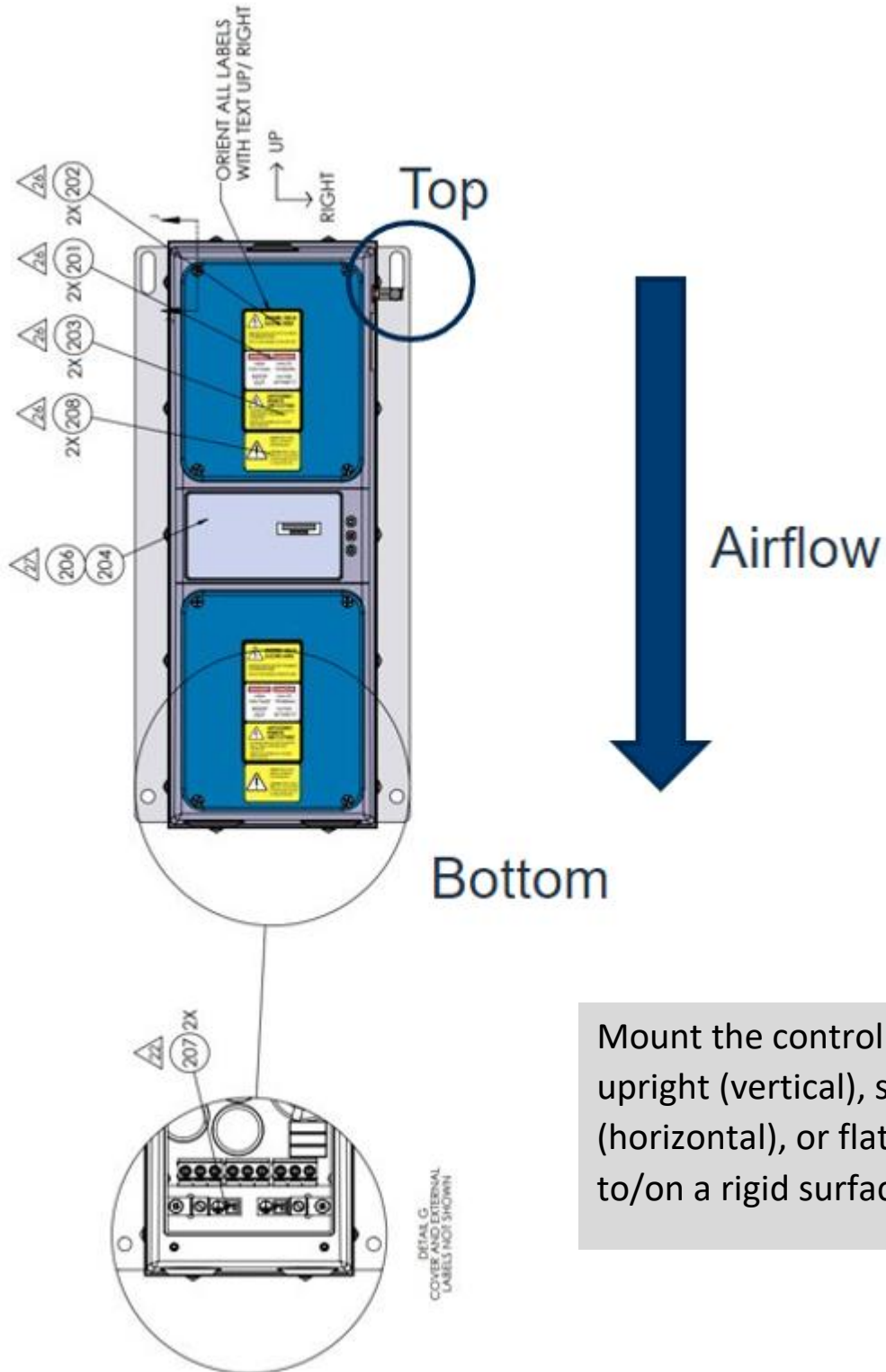

Mount the controller in an upright (vertical), sideways (horizontal), or flat position to/on a rigid surface.

Safety

Precautions

Motor leads between the motor controller and motor must be properly connected and insulated. Improper connection could lead to shorts and arcing, thereby causing equipment damage or personal injury. Take steps to make sure all electrical connections are properly secured. Only qualified personnel should attempt installation, operation, or maintenance of this equipment. **Do not install, operate, or perform maintenance until you have reviewed and understood all warnings and cautions.**



Warning: Do not connect the Turntide motor to any Variable Frequency Drive (VFD) or non Turntide provided motor controller. Turntide HR-SRMs require a specific inverter topology that is inconsistent with off-the-shelf VFDs. Turntide motors cannot be driven across-the-line and thus should not be connected to AC line power.

Motor leads between the Motor Controller and motor must be properly connected and insulated. Improper connection could lead to shorts and arcing, thereby causing equipment damage or personal injury. Take steps to make sure all electrical connections are properly secured.

Electrical shock can cause serious or fatal injury. Do not touch any electrical connections until the power to the motor and all accessory devices has been disconnected and locked out.

Handling

Only qualified personnel should attempt installation, operation, or maintenance of this equipment. Do not install, operate, or perform maintenance until all warnings and cautions have been reviewed and are understood.

All electrical connections should be made only by qualified electrical personnel and in accordance with all applicable codes, ordinances, and sound practices. Be sure you are familiar with NEMA safety standards for selection, installation, and operation of electrical motors, as well as the National Electrical Code. Unsafe installation or use could lead to serious injury, property damage and/or death.

Safety Standards

The following motors, supervisor, and **P06 Motor Controller** are certified to the following USA and Canadian safety standards:

V01/V02/V03 Motors certified to	P06 Controllers certified to
CSA C22.2#77 UL 1004-7 IEC 60204-1 IEC 60034-1	UL 61800-5-1 UL 61800-5-2 IEC 61800-5-1 IEC 61800-5-2 CSA C22.2#274 CSA C22.2#61800-5-2

UL and CSA Standards

- **UL 61800-5-1** Adjustable Speed Electrical Power Drive Systems - Part 5-1: Safety Requirements - Electrical, Thermal and Energy
- **UL 61800-5-2** Adjustable Speed Electrical Power Drive Systems - Part 5-2: Safety Requirements - Functional
- **CSA C22.2#274:2017 Ed.2** Adjustable Speed Drivers
- **CSA C22.2#61800-5-2:2021 Ed.1** Adjustable Speed Electrical Power Drive Systems - Part 5-2: Safety Requirements - Functional

IEC

- **IEC 61800-5-1** Adjustable Speed Electrical Power Drive Systems – Part 5-1: Safety Requirements – Electrical, Thermal and Energy
- **IEC 61800-5-2** Adjustable Speed Electrical Power Drive Systems - Part 5-2: Safety Requirements - Functional
- **IEC 61800-3** Adjustable speed electrical power drive systems - Part 3: EMC requirements and specific test methods

Overall System Standards

- UL 1004-1 Rotating Electrical Machines
- UL 1004-7 Electronically Protected **Motors**
- UL 1004-8 Inverter Duty **Motors**
- CSA C22.2#100 **Motors** and Generators
- CSA C22.2#77 **Motors** with Inherent Overheating Protection
- IEC 60034-1: 2017 (Ed.13.0) Rotating Machines Rating and Performance (**Motors**)
- IEC 60204-1: 2016 (Ed. 6.0) Rotating Machine Basic Safety (**Motors**)

Conformance

- Motor controller suitable for use in other environmental air handling spaces (plenums) in accordance with **Section 300.22 (C) Other Spaces Used for Environmental Air (Plenums)** of the National Electrical Code
- **Required:** Breaker rating 4xxVAC, 30A for
- **Required:** Fuse rating 6xxVAC, 30A, Class RK5
- Breakers must be UL489 SH3 listed



Control Wiring Methods

Defined by a Motor Controller wired in parallel with the 24V signals from the thermostat. Thermostat directly controls RTU heating and cooling stages.

- BMS or Thermostat has **no direct physical connection** to the Turntide motor controller’s inputs
- Turntide motor controller inputs are wired to the RTU unit terminal board
- Turntide motor controller outputs are now available for other potential uses, such as run status or alarm/warning indication. NOTE: Supported only with a Monitor-Only specific cascade flow.
- The thermostat/BMS will send the 24 V signal to the motor controller and RTU unit terminal board simultaneously.

The SL121 and P06 motor controllers are prewired with a blue input cable.

The P04, P05, and SL120 motor controllers are prewired with a **white** input and **black** output cable.

- The **white** input wired in parallel with the thermostat 24V signals to the RTU.
- The **black** cable wired for 24V Common.

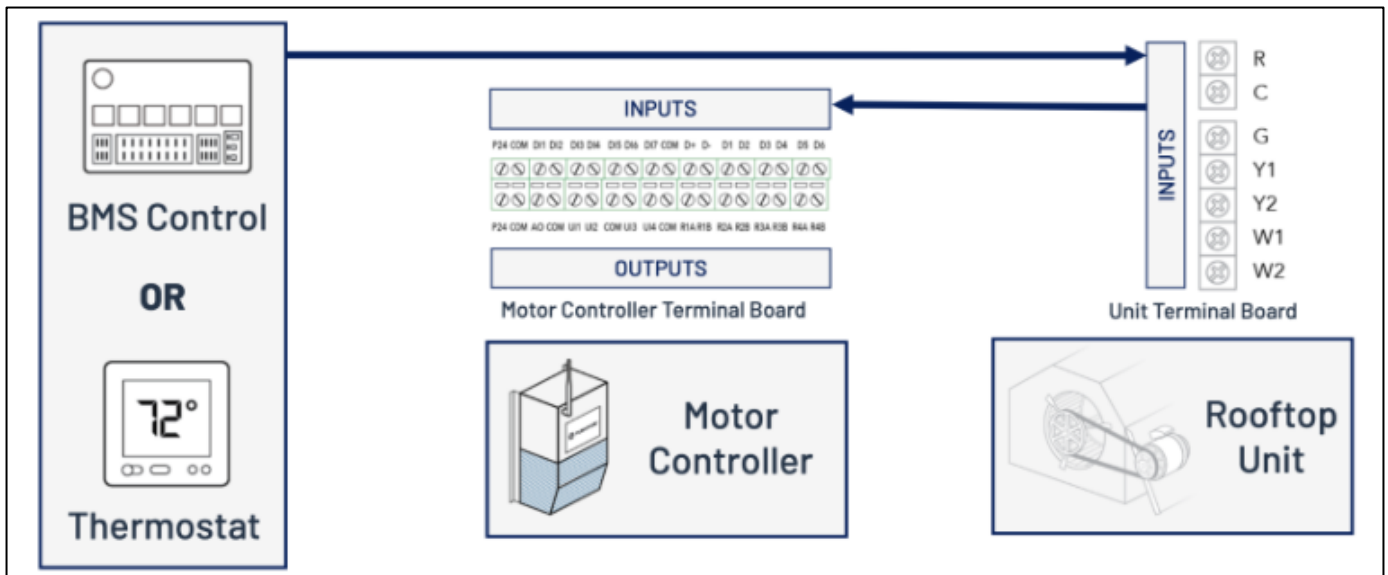

Important: If you are replacing an existing Turntide Motor Controller (P04, P05, SL120) with an SL121 or P06, you will notice that the pre-wiring scheme has changed.

- New controllers are intended for Monitor Only integration.
- If you do not wish to use the new Monitor Only control wiring method but want to maintain the Full Integration control wiring, you MUST use the existing wiring harness. See [How to Replace a P04/P05/SL120 with SL121/P06 Control Wiring](#).

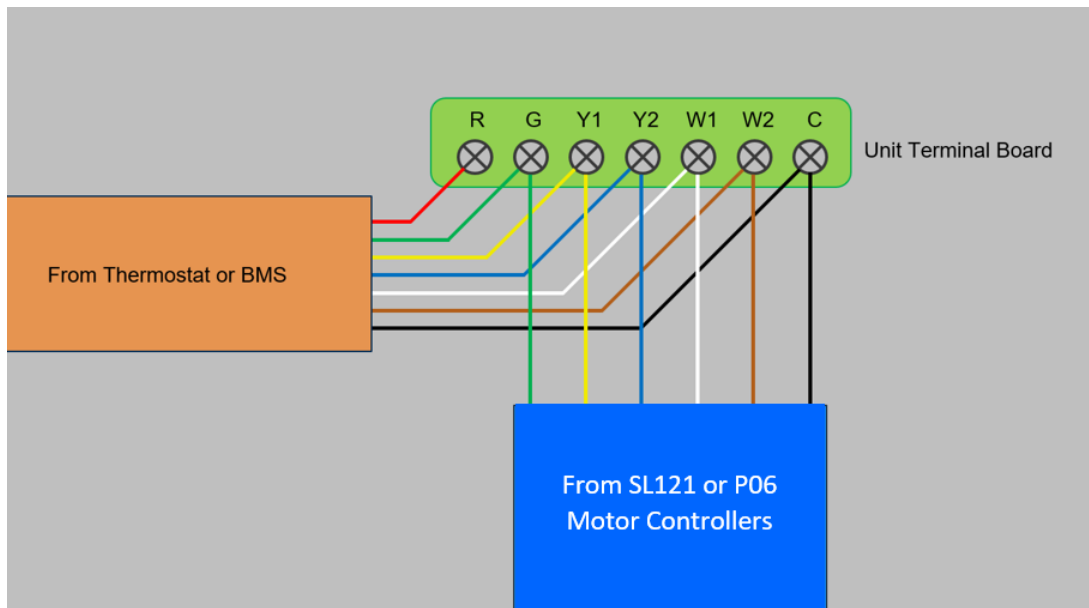

Figure 1 Monitor Only for SL121 or P06 Motor Controller

Motor Controller to Turntide Smart Motor Cabling

- You can use your own cabling between the controller and motor; however, we recommend that you use Turntide-provided power cabling as it may reduce the prevalence of nuisance trips.
- Ensure the motor is properly grounded, securing a grounding wire from the ground stud in the junction box to earth ground. Appropriate clamps or ties should be used to create strain relief for the cable inside the motor controller case.

Power Cabling to Motor Controller

- A 3-phase power cable is required for supplying AC mains power.
- **Required:** Ground wire must be connected.
- Wire size or gauge is based on motor controller nameplate requirements; however, must be sized in accordance with applicable national, state, and local codes.
- Appropriate clamps or ties should be used to create strain relief for the cable inside the motor controller enclosure.
- Always refer to local electrical code guidelines for best practices.
- **Required:** Breaker rating 4xxVAC, 30A for
- **Required:** Fuse rating 6xxVAC, 30A, Class RK5

Overview of Motor Controller Installation Instructions

Mounting Guidelines

Mount the Turntide Motor Controller inside the RTU—ideally in the blower cabinet—using caution not to penetrate the cabinet with the screws. If a suitable location is *not* available, it may be mounted to the exterior of the RTU within an appropriately sized enclosure rated at a NEMA 3R or above, or on a wall of the mechanical room near the RTU. The P06 has an integrated heatsink fan shroud. The P06 does not necessarily require a solid, flat surface for mounting.

We strongly recommend a minimum of:

- 2 inches clearance at the top and bottom of the controller to prevent impeding the airflow path
- 0.5 inches around the sides of the controller to allow the inside ambient to vent

Do NOT install in environments where steam or exposure to water is present.

We recommend that you NOT install the controller in environments that exceed the rated ambient temperature range as the controller may not be able to provide its full rated power.

Do NOT mount the controller in an area where:

- Corrosive fumes, explosion vapors, flammable gas, oil mist, dust, or metal powder are present
- Excessive vibration or shock is likely to occur
- Excessive electrical noise such as large magnetic interference is present from devices, such as solenoids, brakes, large magnetic contactors, or large resistors
- Air intake vents on the sides may be blocked

Wiring

P06 Specific Guidelines

Remove the terminal access cover at the front of the motor controller. All wiring terminals are accessible underneath the terminal cover at the front of the enclosure. The main enclosure cover should only be removed by authorized service personnel.



REQUIRED

Ensure that any control wires on the Turntide motor are isolated by a minimum of 6mm or 0.25" from power cables and never route them through a common conduit or cable tray.

On the P06, you will:

- Connect the A/C supply to the terminals labeled **L1 L2 L3**
- Connect the motor power leads to the terminals labeled **P1 thru P6**

Note: If connecting the controller to an external computer or controller, connect the serial Modbus cable to terminals labeled D+, D-.

Ensure that you connect the AC supply and Motor safety ground wires to the GND terminal lugs inside the terminal wiring cavity.



Branch Circuit: The controller does not provide any AC line input protection. Connect the controller to the supply mains from a branch circuit protected with a **30A circuit breaker** or similar breaker approved by local electrical codes and guidelines. An optional disconnect may be provided at the controller location.

- 6xxV fuse: 600V needs 30A (TRS30R Tri-Onic) fuse branch circuit protection
- 4xxV breaker: 400V needs EBD34030 or equivalent UL489 SH3 listed circuit breaker for branch circuit protection

Follow these guidelines:

1. Size wiring to NFPA 70 NEC 240-3.
2. Keep source (input power) leads separate from motor leads.
3. All AC mains must share the same conduit and conduit entry points to prevent inductive heating.
4. All motor phase leads must share the same conduit and conduit entry points.
5. All AC mains and controller power output cables **must NOT share the same conduit.**
6. Keep control lines separate from power lines (do not share the same conduit).
7. Do not bundle control wires with power cables or run in parallel.
8. Install surge absorber on any magnetic contactor or relay circuits used around the motor controller.

Monitor Only

Wiring Information

P06 Motor Controllers

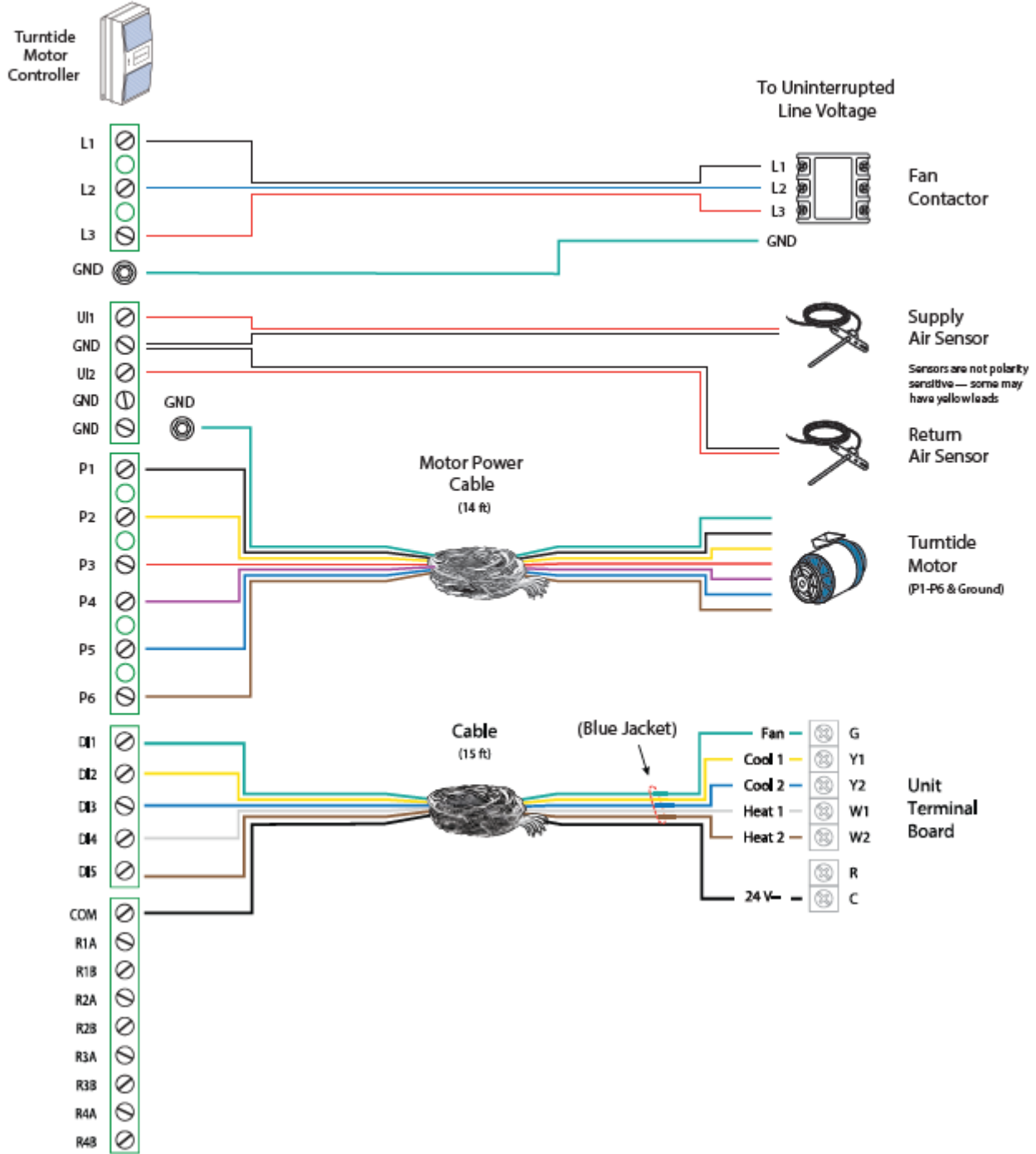

Operation

Switched Reluctance Motors (SRMs) have a distinct sound profile. Similar noise is often associated with failing bearings in induction motors but does not indicate an immediate issue with our system.

Before beginning the initial operational checkout, review the entire procedure to make sure you understand all the steps. Contact Turntide with any questions before proceeding.

Initial Operation Checkout

The initial operational checkout assumes the motor and motor controller have been mounted and properly cabled, and power to the system is turned off. Also, the motor is not yet connected to the load or any auxiliary devices.

1. **Mechanical checks:** Check mounting bolts for tightness. Rotate motor shaft to make sure it rotates freely.
2. **Electrical checks:** Make sure all electrical and ground connections are well made, properly insulated, and have electrical continuity with a multi-meter. Replace any panels or covers that were removed in the installation process before energizing the motor controller or motor.
3. **Apply power to the motor-motor controller system.** Inspect the motor controller to see that the power indicator is illuminated.
4. **Using the Turntide Technician App,** start the motor at a low speed to confirm that the motor shaft is turning. Also verify the direction of rotation is appropriate for the specific installation or application. **You MUST follow instructions in the latest *Turntide Technician App User Guide* available on <https://support.turntide.com/>.**

Maintenance



Do not install, operate, or perform maintenance until all warnings and cautions have been reviewed and are understood. Electrical shock can cause serious or fatal injury. Do not touch any electrical connections until the power to the motor, controller, and all accessory devices has been disconnected and locked out.

General Inspection

Inspect motors regularly, every three months or after 500 hours of operation, whichever occurs first. Keeping motors clean and ventilation openings clean prolongs the life of the equipment.

Perform the following checks during inspection:

- Check motor exterior for oily residue, lint, water, or dirt. Residue on the motor surface can interfere with ventilation.
- Check mechanical and electrical connections for tightness.

Functional Operation

Power Input

Table 6 Power Input

Voltage	Frequency	Phase
208/230VAC	60 Hz	Three-phase
460VAC	60 Hz	Three-phase
575VAC	60 Hz	Three-phase
200/230VAC	50 Hz	Three-phase
400VAC	50 Hz	Three-phase

EMI/EMC Filter

The AC front end of the motor controller incorporates an EMI filter for suppressing both common-mode and differential-mode Conducted EMI noise. The filter consists of a single stage LC filter implemented with a three-phase common mode choke and line capacitors for both common mode and differential mode noise suppression.

Soft Start

An inrush current limiting resistor between the Rectifier Bridge and DC bus capacitors limits the initial charging current of the bulk capacitors. The resistor is shorted out by a relay under firmware control when the DC bus voltage rises to within operating limits. This procedure prevents excessive charging currents from damaging the motor controller or tripping source circuit breakers during power-on sequence.

Brownout

The motor is stopped on an under-voltage condition, which occurs at a voltage greater than the pull-in voltage. If the voltage continues to drop below the pull-in threshold, there is a 0.5s drop-out delay, followed by engagement of the soft-start resistor. The motor will be stopped for at least 0.5s and at most 0.5s plus the time it takes for the voltage to fall from the under-voltage limit to below the pull-in limit. This prevents inrush currents from damaging the motor controller front end when the voltage subsequently rises. The resistor is shorted out when the voltage rises to within operating limits.

DC Bus Discharge

The logic power supply fly back power converter discharges the DC bulk capacitors when power is removed from the board. Wait five minutes between removing power to the motor controller and accessing the power terminals to prevent electrical shock.

Power Stage

The power stage configuration consists of three Insulated-Gate Bipolar Transistor (IGBT) asymmetric bridge converters, one for each motor phase. The power stage functions as a current source to regulate each motor phase current using either Hysteresis or Pulse Width Modulated (PWM) control methods. Each asymmetric bridge is electrically isolated from each other enabling several performance control, reliability, and fault tolerant benefits.

DSP Controller

The controller consists of high-power output stages electrically isolated from the DSP controller. CPU1 is used for all external communications over the Modbus interface to the Turntide Controller. CPU2 is used for all motor operations.

Motor Controller Configuration Settings

You can configure the controller with the following settings through either the *Turntide Technician App* or through [Windows PC Desktop Application for controlling the Smart Motor System](#) or via the Modbus serial interface by external means. The controller may be preconfigured at the time of manufacture with customer specific settings.

Table 7 Motor Controller Configuration Settings

Parameter	Default	Description
Speed Control Mode	0 Voltage	Sets the control source for the speed signal <ul style="list-style-type: none"> • Voltage [default]: a 0-10V signal is used to control speed between the minimum (0V) and maximum (10V) speeds. • Current 0-20mA: a 0-20mA signal is used to control speed between the minimum (0mA) and maximum (20mA) speeds. • Current 4-20mA: a 4-20mA signal is used to control speed between the minimum (4mA) and maximum (20mA) speeds. • Digital Inputs: speed commands are received through the Digital Inputs Tap selection
Acceleration_time	10 sec	The time to change the speed by 2000 RPM. The speed ramp starts at 100 RPM. No ramp control occurs at speeds 0-100 RPM. A setting of 0 will cause the motor to accelerate as quickly as possible.
Deceleration_time	10 sec	The time to change the speed by 2000 RPM. A setting of 0 will cause the motor to decelerate as quickly as possible.
Motor Directions	0 [Forward and Reverse]	Sets the directions in which the motor is allowed to operate <ul style="list-style-type: none"> • Forward and Reverse [default]: both forward and reverse directions are permitted. • Forward Only: the motor can only rotate in the forward direction.
Min Speed	100 rpm	Sets the lower bound for the speed operating range. This value must be greater than the motor datasheet minimum speed.
Max Speed	3600 rpm	Sets the upper bound for the speed operating range. This value must be lower than the motor datasheet maximum speed. Note: This setting must be confirmed to clear the Uncommissioned Motor state.

Parameter	Default	Description
Auto Restart Attempts	2 attempts	Sets the number of restart attempts allowed. [Default 0] The counter is reset when one of the following occurs: <ul style="list-style-type: none"> • The motor operates without fault for 10 minutes • The faults are cleared by the user • The motor controller power is turned off and on. The time between successive restart attempts is set in Restart Interval.
Auto Restart Interval	10 sec	Sets the amount of time to wait between successive restart attempts.
Skip_Speed_1	50 rpm	The first prohibited speed reference point for eliminating problems with resonant vibration of the motor. This feature does not eliminate the selected speed values but accelerates and decelerates the motor through the prohibited bandwidth.
Skip_Speed_2	150 rpm	The second prohibited speed reference point for eliminating problems with resonant vibration of the motor. This feature does not eliminate the selected speed values but accelerates and decelerates the motor through the prohibited bandwidth.
Skip_Speed_3	200 rpm	The third prohibited speed reference point for eliminating problems with resonant vibration of the motor. This feature does not eliminate the selected speed values but accelerates and decelerates the motor through the prohibited bandwidth.
Skip_Width	50 rpm	The dead-band interval around each selected skip speed reference point. Important: Speeds between the skip speed – 0.5 * dead band and skip speed + 0.5 * dead band are prohibited .
Digital Input DI1	3	Sets the action taken when this digital input is open or closed. Motor Enable (Open = Motor Enabled, Closed = Motor Disabled)
Digital Input DI2	1	Programmable option as per Table 8 Digital Input Program Options
Digital Input DI3	2	Programmable option as per Table 8 Digital Input Program Options
Digital Input DI4	4	Programmable option as per Table 8 Digital Input Program Options

Parameter	Default	Description
Digital Input DI5	5	Programmable option as per Table 8 Digital Input Program Options
Digital Input DI6	7	Programmable option as per Table 8 Digital Input Program Options
Digital Input DI7	8	Programmable option as per Table 8 Digital Input Program Options
Digital Output 1	3	Sets the condition that activates the digital output. <ul style="list-style-type: none"> • Motor controller Active (open = inactive, closed = active) • Motor Running (open = not running, closed = running) • Active Fault [default] (open = no faults, closed = faults) • Active Alert (open = no alerts, closed = alerts) •
Speed Setting 1	600 rpm	Sets the speed point that corresponds to Speed tap setting 1.
Speed Setting 2	900 rpm	Sets the speed point that corresponds to Speed tap setting 2.
Speed Setting 3	1200 rpm	Sets the speed point that corresponds to Speed tap setting 3.
Speed Setting 4	1500 rpm	Sets the speed point that corresponds to Speed tap setting 4.
Speed Setting 5	1800 rpm	Sets the speed point that corresponds to Speed tap setting 5.

See also: [Motor Controller Interface Options](#)

Digital Input Program Options

Actions taken by the motor controller when the assigned digital input is open or closed.

Table 8 Digital Input Program Options

Option	Setting
1	Run (open=stop, closed = run)
2	Reverse (open = forward, closed = reverse)
3	Motor Enable (Open = Motor Enabled, Closed = Motor Disabled)
4	External Fault N.O. (open = no fault, closed = fault)
5	Reset Faults (close = reset faults)
6	Reset to factory defaults
7	Speed tap setting 1 (closed = run at setting 1 speed)
8	Speed tap setting 2 (closed = run at setting 2 speed)
9	Speed tap setting 3 (closed = run at setting 3 speed)

Sensors

Phase current (IPH)

Phase current regulation is the fundamental means for controlling torque and subsequently speed of the SRM. A resistive shunt with isolating differential voltage amplifier on each motor power lead is used as the measurement technique.

DC bus voltage (DC_BUS_VOLTAGE)

The DC bus voltage at the input to the motor controller is used for calculating input power and phase turn on angle tuning. Due to the rectification from AC to DC, the bus voltage should be expected to be around $1.414 \times \text{AC Line Voltage}$. Additional external factors such as diminished power quality or the presence of elevated harmonic distortion may cause this value to deviate from expected norms.

Motor and Motor Controller Protection

Methods used to protect the Motor Controller and Motor systems.

Faults and Error Conditions

FAULT REACTION TIME: Time between the detection of a fault and the point where the motor controller controls are disabled. The shutdown state or lock-out condition persists for as long as the fault is active.

N/A = Motor not started. Remains in the disabled or stop state.

Table 9 Faults Group 1

Fault Number	Description	Reaction Time	Trip Value
0	Fault Phase Current Overload	<10 usec	See over-current protection section
2	Fault Heatsink Temperature	1 sec	100 deg C
3	Fault Enclosure Temperature	1 sec	70 deg C
4	Fault Bus Voltage	250 msec	See overvoltage and undervoltage limit section
5	Fault External	10 msec	N/A
6	Fault No Motor	1 sec	N/A
8	Fault Not Commissioned	1 sec	N/A
9	Fault Incompatible configuration	1 sec	N/A
10	Fault Restart attempts exceeded	1 sec	N/A
11	Loss of Phase (Excessive DCV Ripple)	2 sec	70Vpp
12	Motor Stalled – fast (commutation)	10 msec	2A above command
	Motor Stalled – slow (thermal protection)	30 sec	200rpm speed error AND Speed < ¼ reference AND Current > ½ max

Table 10 Faults Group 2

Fault Number	Error Description	Reaction Time	Trip Value
0	Power On Self-test (POST) failure	N/A	N/A
2	Phase C current sensor faulty	10 msec	N/A
3	Phase B current sensor faulty	10 msec	N/A
4	Phase A current sensor faulty	10 msec	N/A

Phase Over-current and DC Bus Over-voltage Protection

Each motor phase current A, B and C and the DC Bus current is compared with a fixed reference current to generate a trip or crowbar signal that disables the motor controller during an over current condition. The trip point is set at a safe point to protect the motor controller and motor.

All P06 motor controllers have a 35A current trip point.

Locked Rotor Detect

A locked rotor condition is determined when the motor is started. The current reaches a predetermined limit, and no rotation is detected. Under this condition the motor controller is disabled. After 10 seconds, another startup is attempted. If the locked rotor condition persists after two retries, the motor controller is disabled, and the RED Fault LED illuminated.

Over Voltage and Under Voltage Limit

Voltage limits are set at the NEMA +/-10% limits of the service supply. The motor nameplate rating is stored in the motor controller flash memory and used to determine the alert trip points.

Table 11 Over Voltage and Under Voltage Limits

Model	Voltage Class	Under-Voltage Limit	Over-Voltage Limit
P06	208-230	178	272
P06	380-480	343	552
P06	575-600	494	649

Performance at NEMA voltage limits is not optimum.

Over Speed Limit

Motor nameplate in Flash contains the rated speed for the motor. Over speed alerts are generated from this specification. **Note:** NOT implemented for firmware versions less than 2.8.

Enclosure Temperature Monitor

A temperature-to-digital converter device on the motor controller motherboard is used to sense enclosure temperature. An alert may be generated if the temperature exceeds a preset limit of 60°C.

Heatsink Temperature Monitor

A thermistor mounted inside the Insulated-Gate Bipolar Transistor (IGBT) module on the device substrate monitors the IGBT case temperature. A warning alert will be generated if the temperature exceeds a preset limit of 90°C. The maximum temperature at which the motor controller shuts down is 100°C.

Peripheral Functions

The following are user-accessible peripheral functions of the motor controller.

LED Indicators

Three LEDs are provided to indicate various motor controller states such as **RUN**, **FAULT** and **WARNING**. The LEDs have the following characteristics: **On**, **Off**, **Slow Flashing**, **Fast Flashing**, **Flicker**. The – (dash) in the following table is equivalent to *not applicable*, meaning its characteristic has no impact on the how you interpret the state.

The antenna location indicates the top of the controller. If the LEDs on your controller are **NOT** color-specific, use their vertical order when consulting the following table:

- **Yellow** LED at top
- **Red** LED in middle
- **Green** LED at bottom



Table 12 LED States

Yellow (Top LED) Indicator	Red (Middle LED) Fault	Green (Bottom LED) Active	Meaning
On	On	On	The motor controller has power but has NOT started up yet. If this sequence remains lit for more than one minute, the motor controller software has been corrupted, and the motor controller should be replaced.
Off	Off	Off	There is a power fault. One of the following may be the cause: the motor controller is not being supplied with sufficient power, the controller is locked up (requires power cycle), OR the controller has failed.
-	On	Fast flashing	The motor controller is incompatible with the supply voltage, or the motor not supported, or the motor is not attached to the motor controller.
-	Off	On	The motor is in a state where if a RUN command is issued, the motor will run.
-	On	Off	There is a critical fault with the motor causing the motor to stop. The indicator will remain On until the fault is reset.
On	-	-	The motor is in manual mode.
-	-	Slow flashing	The motor is in Identify/Waiting to restart after fault mode.
-	Fast flashing	-	Safety Stop active.

Yellow (Top LED) Indicator	Red (Middle LED) Fault	Green (Bottom LED) Active	Meaning
-	Slow Flashing	-	A warning fault with the motor, but the motor can continue running. The indicator will remain On until the fault is reset.
Two flashes every 5 seconds	-	-	A logic flow is running on the motor controller.
-	-	Flicker	Modbus or Wi-Fi communications active.

Modbus Interface

An isolated 2-wire RS485 Modbus RTU (Remote Terminal Unit) interface is used to communicate with the motor controller. The format for each byte in RTU mode is:

Coding System	8-bit binary
Bits per Byte	1 start bit 8 data bits, least significant bit sent first 1 bit for parity completion 1 stop bit
Default baud rate	19,200 bps
Default address	F7
Address range	1-247
Default parity mode	Even
Signal Termination	150 ohm resistor with disconnect (see Modbus termination resistor)

Wi-Fi Interface

The Motor Controller implements an 802.11 b/g/n wireless interface for motor control functions with the following specifications:

Manufacturer	Espressif Inc.
Model Number	ESP32-WROOM-32U
Description	Wi-Fi & Bluetooth Internet of Things Module (Bluetooth not used on this product)
RF Certification	FCC/CE-RED/IC/TELEC/KCC/SRRC/NCC
Protocols	802.11 b/g/n (802.11n up to 150 Mbps)
Frequency range	2.4 GHz ~ 2.5 GHz (single band)
Antennae Type	External Whip Monopole with SMA connector
Antennae Gain	-2dBi
Complies with	FCC ID: 2AC7Z-ESP32WROOM32U IC: 21098- ESPWROOM32U

Note: If your business/organization requires that you manually disable Wi-Fi on the SL121 or P06 motor controller, please contact Turntide Technical Services for instructions.

External Fan

The P06 motor controller has two external cooling fans that provide airflow across the heat sink.

Grounding

1. Terminate AC supply ground at the motor controller input ground lug. Lug wire range (2~14 AWG).
2. Connect the ground wire from the motor enclosure to motor controller ground lug within the enclosure.
3. Size ground wires in accordance with NFPA 70 NEC Section 250.

The system grounding topology is illustrated as follows.

Figure 2 System Grounding Topology P06 Motor Controller

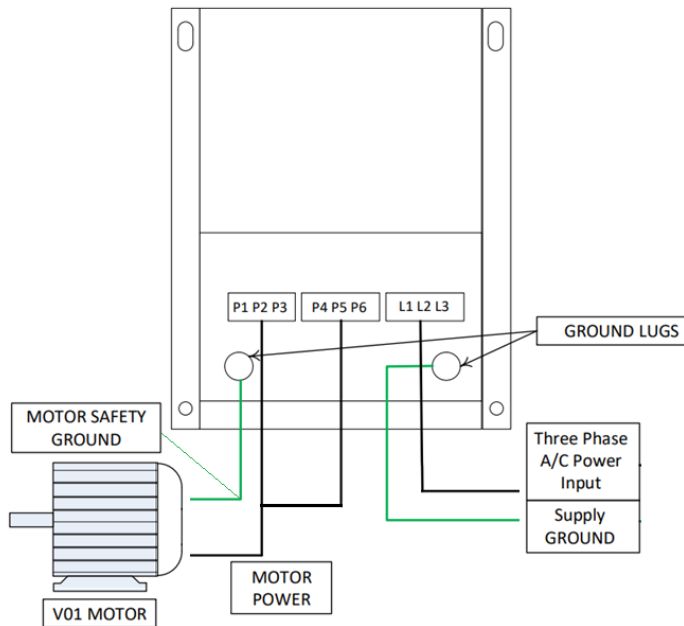

Grounding Lugs

Model P06-xxxx-xx -M5 Size, Zinc-Plated Steel. **Two lugs, one for:**

- Input supplier power ground
- Motor ground

The lugs accommodate 2-14 AWG ground wire, 4-16 AWG with ferrule, and 4-12AWG flex wire.

Safety Requirements

- To meet IEC requirements, two protective earthing connections must be made using both ground lugs on the motor controller.
- The minimum grounding conductor for both source and motor must follow guidelines outlined in NEC Section 250-2 (d) & Section 250-120.

Connections

- Power Connections
- Control Connections
- Digital Input Connections

Power Connections

The main AC input and motor terminal connections are illustrated as follows:

Figure 3 Power Connections

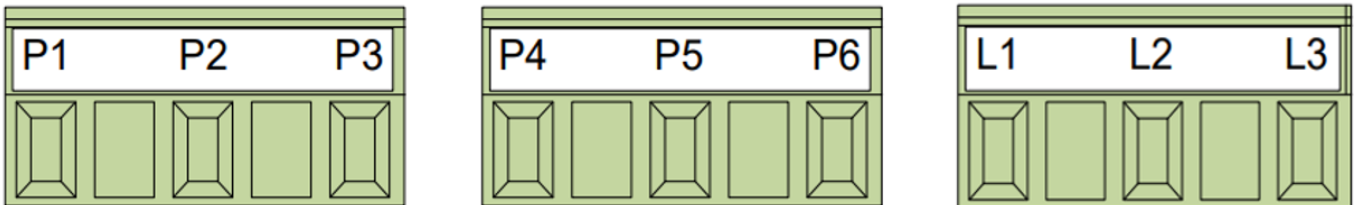

Table 13 Motor Terminal and AC Supply Termination Description

Pin	Name
P1	Phase A to motor
P2	Phase A from motor
P3	Phase B to motor
P4	Phase B from motor
P5	Phase C to motor
P6	Phase C from motor
L1	AC Mains Input Phase L1
L2	AC Mains Input Phase L2
L3	AC Mains Input Phase L3

Control Connections

Controller	Connections	Labeling in unit
P04 and P05 controllers	UI1-UI4 are NOT isolated and all four are referenced to GND.	GND is labeled as AC and COM is labeled as SC .
SL120 controller	UI1-UI4 are ALL isolated and ALL are referenced to COM.	Labeled as COM in the controller.
P06 and SL121 controllers	Only the UI4 is isolated and referenced to COM. UI1-UI3 are referenced to GND.	Labeled as COM and GND in the controllers.

Important: No more than two conductors should be terminated on any individual terminal to ensure solid contact.

Figure 4 P06 Control Terminal Connections



Definitions

- **COM (System Common)** represents an isolated (within the motor controller) common that is referenced to the user's system elements, i.e., the common reference for the system in which the motor controller is being installed.
- **GND (Motor Controller Common)** represents the common for most of the control circuitry within the motor controller.

In the P06 motor controller, COM and GND are electrically isolated from each other.

Auxiliary Power Output

Table 14 Auxiliary Power Output

Pin	Name
P24	Isolated 24VDC for powering users' sensors (up to 250mA)
COM	System Common

Digital Input Connections

Digital inputs are activated by **connecting the corresponding input DI1 through DI7 to the COM terminal** in dry contact mode.



Never wire digital inputs to a contactor coil without isolation such as an interposing relay or using available auxiliary contacts. If you do not isolate the inputs, inductive kickback can damage the device.

See [Switch Options](#) to set the Digital Input signaling mode (24VAC or dry contact).

Table 15 Digital Input Connections

Pin	Name
DI1	STO (Safe Torque Off)
DI2	Programmable Digital Input 2
DI3	Programmable Digital Input 3
DI4	Programmable Digital Input 4
DI5	Programmable Digital Input 5
DI6	Programmable Digital Input 6
DI7	Programmable Digital Input 7
COM	System Common

Modbus Connection

- When using the Modbus interface D+ D- for communications, connect the signal return of the motor controller to the signal return of the controlling equipment.
- Use the COM pin for the Modbus signal return. This is necessary to limit the common mode voltage to an operational level. Connect drain wire of shielded multi-conductor cable on one end only to control source ground.

Table 16 Modbus Connection

Pin	Name
D+	Modbus D1 (Positive)
D-	Modbus D0 (Negative)

Analog Output Connection

- Use shielded twisted cable for analog connections.
- Connect drain wire of shielded multi-conductor cable on one end only to control source ground.

Table 17 Analog Output Connection

Pin	Name
AO	Analog Output
GND	Motor Controller Common

Universal Analog Inputs

Table 18 Universal Analog Inputs UI1-UI3

Pin	Name
GND	Motor Controller Common
UI1	Universal Analog Input 1
UI2	Universal Analog Input 2
UI3	Universal Analog Input 3

Table 19 Universal Analog Inputs UI4

Pin	Name
UI4	Universal Analog Input 4
COM	System Common

Table 20 Relay Outputs

Pin	Name
R1A R1B	Relay Output 1
R2A R2B	Relay Output 2
R3A R3B	Relay Output 3
R4A R4B	Relay Output 4

Switch Options

Universal inputs define the connected device type. The Universal inputs may be configured in one of **three modes (I, V, R)** via DIP Switches.

- **Voltage (V):** 0-10V (may be used to control the inverter directly or used to monitor CO2 or other sensors in HVAC systems)
- **Current (I):** 0-20mA or 4-20mA (may be used for direct current loop control of the motor controller)
- **Resistive (R):** Thermistor temperature sensors (may be used to monitor ambient air, return air, and supply air temperatures in HVAC systems)

Notes:

- Position 1 ON is the **resistive mode**
- Position 2 ON is the **voltage mode**
- Position 3 ON is the **current mode**.



ONLY one switch position should be ON at a time.

SW7 for Modbus Termination Resistor and Digital Input Mode

SW7 is used for both the Modbus Termination Resistor and Digital Input mode settings selection. Digital or Discrete Inputs initiate a programmed response of the motor controller based on parameter settings.

The blue D+ D- cap is easily removed to improve access to SW7.

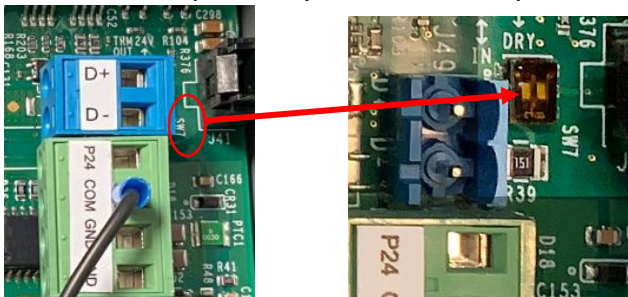

P06 Motor Controller User-Selectable Switch Options Diagram

Figure 6 User-Selectable Switches P06

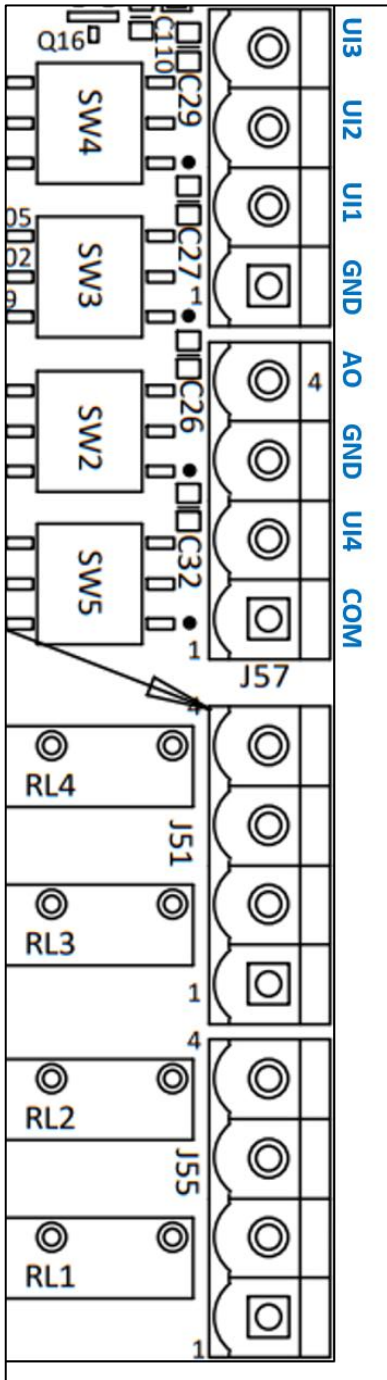



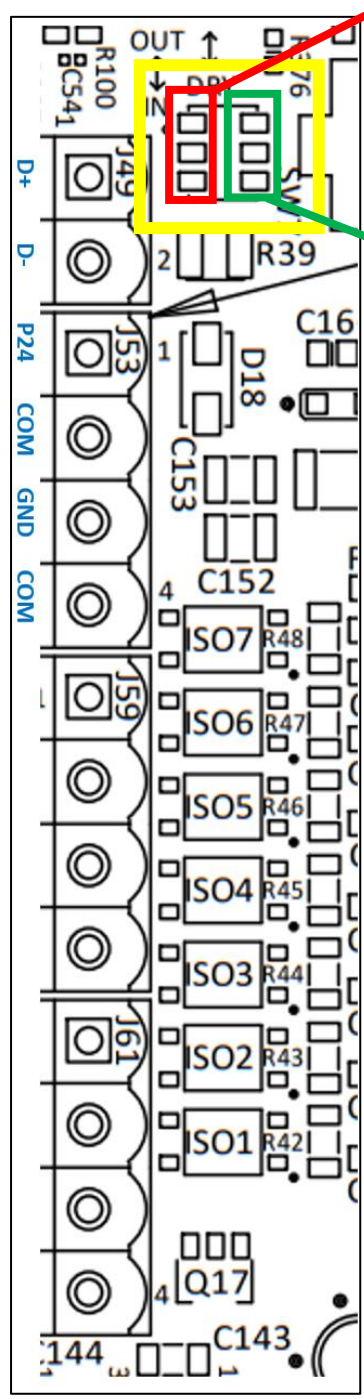



- UI3 (SW4)
- UI2 (SW3)
- UI1 (SW2)
- UI4 (SW5)



SW7: Digital Input Mode

User-Selectable Switch Options Usage & Examples

Motor Controller Model	Modbus Termination Resistor Switch	Digital Input Mode Switch	Universal Input Mode Switches			
			U1	U2	U3	U4
P06	SW7	SW7	SW2	SW3	SW4	SW5
Modbus Termination Resistor Selection						
Switch Position		Mode	Examples			
Left DOWN position 		Modbus termination resistor is enabled	Set if wiring to terminals D+/D- is end of daisy chain.			
Left UP position 		Modbus termination resistor is disabled				
Digital Input Mode Selection						
Switch Position		Mode	Examples			
Right DOWN position 		Enables digital inputs LOGIC or dry contact mode.	Set if DI1 through DI7 will be used to receive contact closures for control.			
Right UP position 		Enables digital inputs 24VAC signaling mode.	Set if DI1 through DI7 will be used to received 24VAC input signal from existing BMS or thermostat.			

Motor Controller Model	Modbus Termination Resistor Switch	Digital Input Mode Switch	Universal Input Mode Switches			
			UI1	UI2	UI3	UI4
P06	SW7	SW7	SW2	SW3	SW4	SW5
Universal Input Mode Selection						
UI1 to UI4 DIP Switch ON		Mode	Examples			
 <p>Caution: ONLY one switch position should be ON at a time; otherwise, may cause damage to the motor controller.</p> <p>R</p> 		<p>Resistive/LOGIC: Returns resistance of connected element or ON/OFF if declared as resistive or LOGIC mode respectively.</p>	<p>Resistive: 2 wire 10K Ω thermistor</p> <p>LOGIC: Dry contact closure = ON Dry contact open = OFF</p>			
 <p>Caution: ONLY one switch position should be ON at a time; otherwise, may cause damage to the motor controller.</p> <p>V</p> 		<p>Voltage: 0-10V signal ended voltage input.</p>	<p>3-wire device with external power source that provides 0-10V signal. (1 signal, 1 common, 1 power)</p>			
 <p>Caution: ONLY one switch position should be ON at a time; otherwise, may cause damage to the motor controller.</p> <p>I</p> 		<p>Current: 0-20mA current input.</p>	<p>3-wire device with external power source that provides a 0-20mA signal. (1 signal, 1 common, 1 power)</p>			

Motor Controller Interface Options

Important: Your primary interface should **ALWAYS** be with the **Turntide Technician App**. See <https://support.turntide.com/> for the latest *Turntide Technician App User Guide*.

Note: This guide also provides instructions for Turntide employees who may need to connect to the motor controller over Modus using a Windows Desktop Application. See [Turntide Windows PC Control App](#) in the [Appendix](#).

Specifications

Operation Conditions

Table 21 Operation Conditions

Symbol	Parameter	Min	Nom	Max	Units
Frequency	Supply frequency	47.5	60	63	Hz
Mean Sea Level (MSL)	Altitude			1000	M
Ta	Ambient Operating Temperature	-10		40	deg C
RH	Relative Humidity noncondensing			95	%

Electrical Characteristics

Table 22 Electrical Characteristics

Symbol	Parameter	Nom	Units
SCCR	Short circuit current rating	5*	k AIC
THD(I)	Total Harmonic Current Distortion	64.6	%
THD(v)	Total Harmonic Voltage Distortion	5.4	%

* Above 5kAIC requires an external input breaker.

Mechanical

Table 23 Motor Controller Mechanical Specifications

Parameter	Specification
Dimensions	See P06 Motor Controller Dimensions
Material	SECC Metal, Aluminum extrusion heatsink
Weight	11.0lb (5.0kg)
Construction	Independently mounted Enclosure for surface mounting Screw mounting tabs on side used to secure unit to a flat surface

Input/Output

Table 24 IO Specification

Type	Specification
Universal inputs	4 universal inputs, individually selectable as: Voltage mode: 0-10V Current mode: 0-20mA or 4-20mA Resistive mode External logic mode
Digital inputs	7 programmable digital inputs
Analog outputs	1 programmable analog output: 0-10V, 0-20mA or 4-20mA, user selectable
Relay outputs	4 relay outputs: 0.3A, 125VAC limit
Aux power outputs	2 24VDC Aux power outputs (up to 500mA)

Wire Gauge and Torque

Wire size or gauge is based on motor controller nameplate requirements; however, must be sized in accordance with applicable national, state, and local codes.

Table 25 Wire and Gauge Torque P06 Motor Controller

Terminal	Wire range	Temperature rating	Screw size	Torque
L1, L2, L3	0.5~16 mm ² or 20~6 AWG	-40C to 105C	M7	1.2 Nm or 10.53 in-lb
P1, P2, P3, P4, P5, P6	0.5~16 mm ² or 20~6 AWG	-40C to 105C	M7	1.2 Nm or 10.53 in-lb
DI1, DI2, DI3, DI4, DI5, DI6, DI7	0.08mm ² ~4mm ² or 28~12 AWG	-40C to 105C	M3	0.5 Nm or 4.43 in-lb
D+, D- I+, I- V+, V-	0.08mm ² ~4mm ² or 28~12 AWG	-40C to 105C	M3	0.5 Nm or 4.43 in-lb



Required: Refer to CSA22.2 No. 274:17 Table 27 for wiring sizes or NEC Section 250-2 (d) & Section 250-120 and any applicable local codes.

Ratings

The enclosures for the following models have been evaluated for materials and construction for dust and water intrusion IP Code and Plenum Rating. *Where applicable, units are tested per IEC 60529 Degrees of Protection Provided by Enclosures (IP Code) and per UL 2043 (as required by the standard UL 61800-5-1) for Fire Test for Heat and Visible Smoke Release for Discrete Products and Their Accessories Installed In Air-Handling Spaces.*

Table 26 Enclosure IP, Plenum, UL Rating

Model	IP Code	Plenum rating	UL rating
P06	IP65	Compliant	V0

P06 Block Diagram

Figure 7 Block Diagram

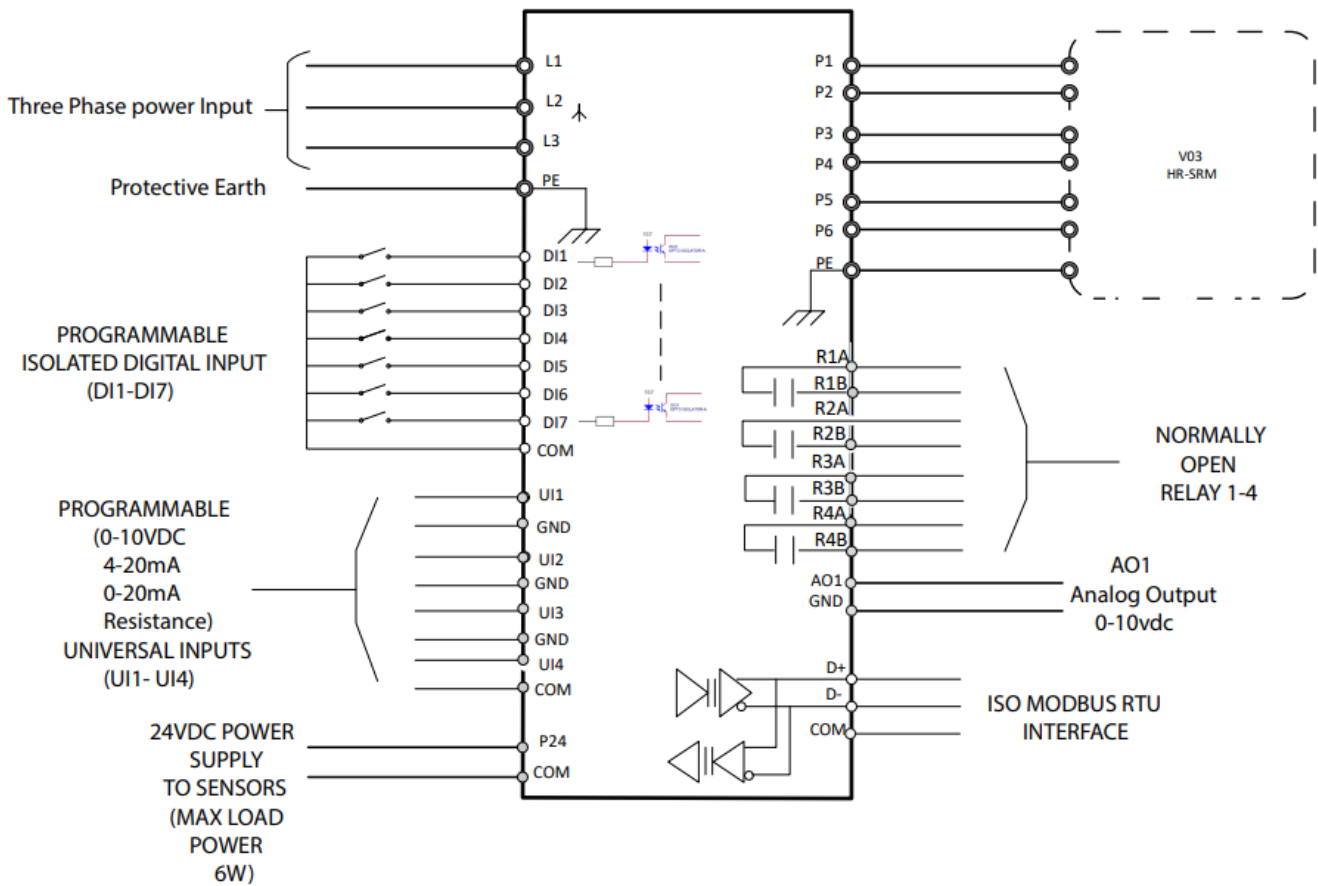

Appendix

Turntide Windows PC Control App (SMCUI)

Audience:

- **ONLY** Turntide employees
- **Users who need to make a critical update without the Turntide Technician App**

Support:

- The SMCUI is currently *not* supported with updates.

Terminology:

- **Digital Input 1 = Motor Enable** in this *P06 Technical Reference Guide* but in the SMCUI it reads as “Safety Stop.”

This section provides basic procedures for common functions of the Windows Desktop Application *also known as the SMCUI (Smart Motor Controller User Interface)* for controlling the Smart Motor System. A connection may be established with the motor controller either over the Modbus serial port or the network Wi-Fi interface.

Connecting to the Motor Controller over Modbus



Modbus connections can exhibit some vulnerabilities particularly with the firmware update process. **Wi-Fi interfacing is the only officially supported method of firmware updates.**

To connect the Windows PC control application to the motor controller:

1. Connect Modbus cable to the motor controller D+, D- and COM terminals as per cable labels.
2. Connect the USB-RS485 adapter to a USB port on the PC.
3. Make all required electrical power and grounding connections.
4. Power up the motor controller with AC Mains 230V/460V power.
5. Open the App and click the **Motor Controller** icon.
6. In the Select Mode dialog box, select **USB**. The App will automatically attempt to detect the USB-RS485 adapter or network interface and establish communications with the motor controller.
If a connection is not established over the Modbus interface through auto port detect, click the **USB Settings** icon the main screen.
7. In the **Port Settings** dialog box, move the **Port Selection** slider to **Manual**.
8. Select the COM port where the USB-RS485 adapter is connected and click **OK**.
9. The application will now attempt to establish communication with the motor controller at the specified port.

Figure 8 Main Motor Controller App Screen



Figure 9 Connection Mode



Figure 10 Manual USB Port Settings



Connecting to the Motor Controller Over Wi-Fi

Two methods are available to connect to the motor controller over Wi-Fi.

- Method 1 provides a direct connection to the motor controller’s access point as identified by the motor controller’s serial number.
- Method 2 connects or associates the motor controller to a wireless network.

Method 1: Connecting to the motor controller’s Access Point

1. Connect to the motor controller Wi-Fi access point by searching for its serial number in the Wi-Fi list.
2. Click **Discovery** to find the motor controller and establish a connection.

Figure 11 Connect to Motor Controller Network

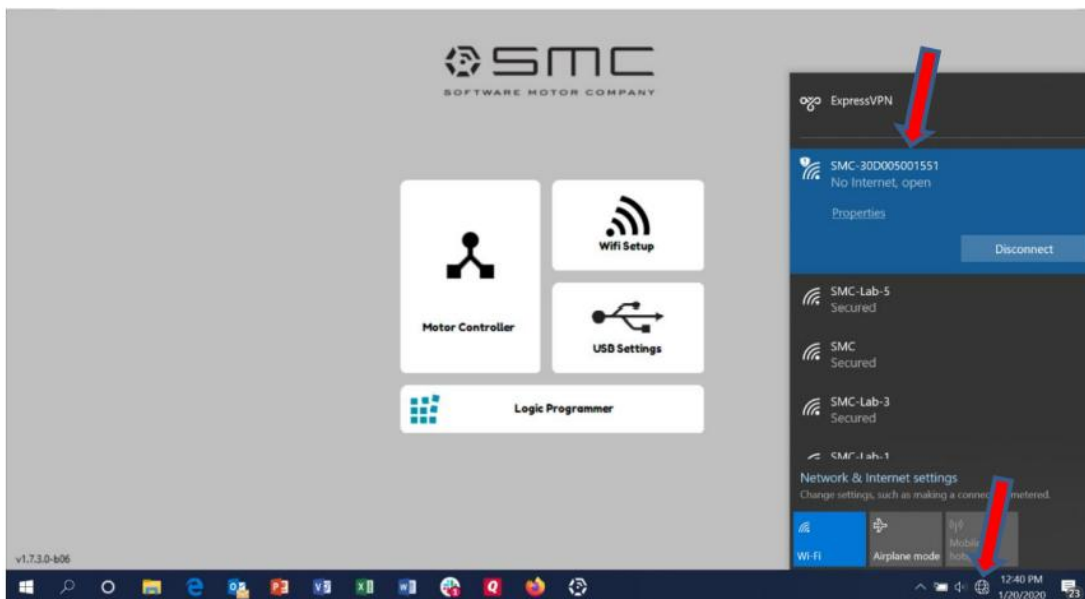

Note: If your business/organization requires that you manually disable Wi-Fi, see [How to Disable Wi-Fi through Hardware on P06 Motor Controller](#) AFTER motor commissioning completed.

Figure 12 Discover Motor Controller Network

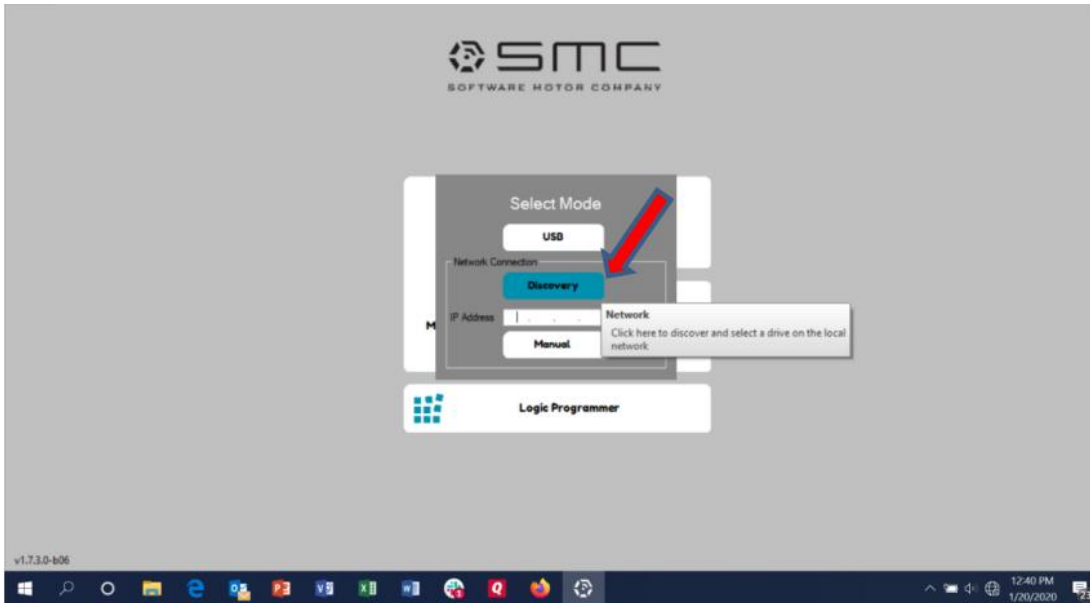

Method 2: Connecting to a Wireless Network

Use the following procedure to configure the motor controller Wi-Fi network interface and connect over Wi-Fi:

1. Click on the **Wi-Fi setup** icon.

Note: The controlling computer must be on the same network as the drive you are connecting to.
2. Enter the **SSID** and **Password** of the access point in the fields displayed.
3. Select **Manual** mode to enter the **Serial Number** and connect to a specific motor controller.
4. Select **Automatic** to scan for all drives on the network.
5. Click **Start** to scan for motor controllers. A pop-up box will appear when the motor controller is found and configured.
6. Click **Ok**.
7. Click on the **motor controller** icon .
8. In the **Select Mode** box, click **Discovery** to connect to the motor controller.
9. Select the drive to connect to.

Note: If more than one Drive is found, a dropdown list of Drives will be displayed by Serial Number. The serial number of the drive is printed on the product label on the top cover.

Figure 13 W-Fi Access Credentials

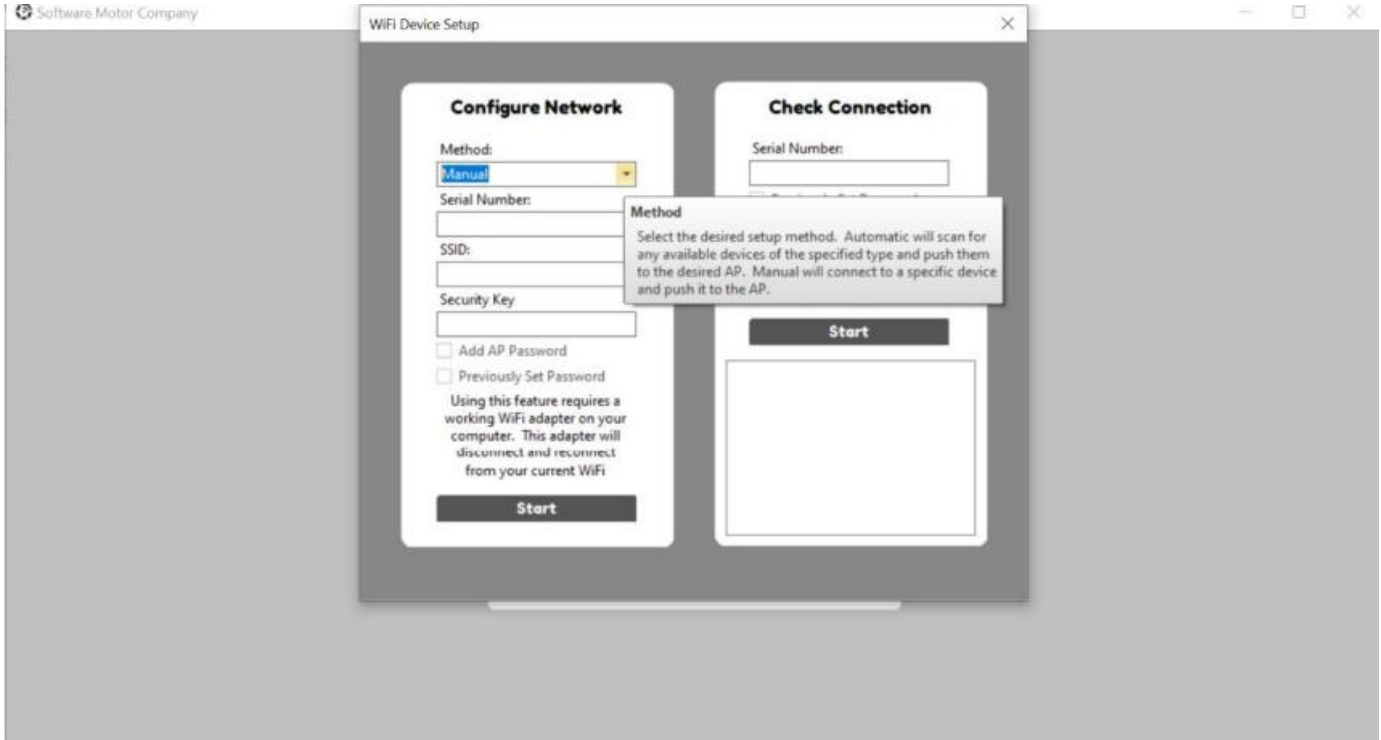

Motor Controller Drive Details

To determine the motor controller firmware version:

1. At the main control screen, click the **Information** icon in the **Smart Motor Drive** section.
2. A popup window displaying details about the motor controller appears.

The **Firmware** version is shown circled in the pop-up window.

Figure 14 Motor Screen

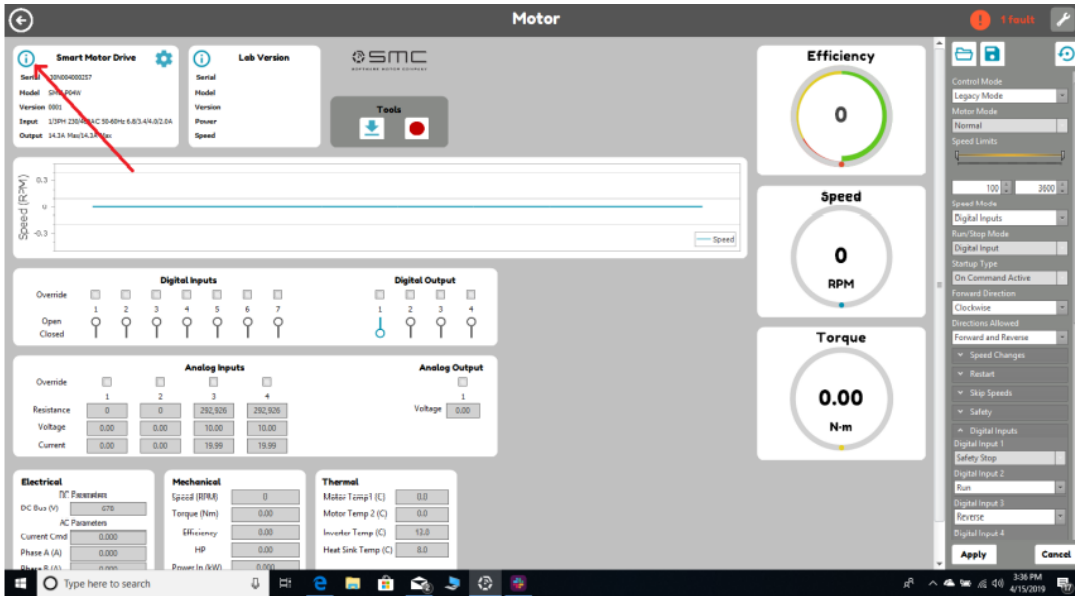
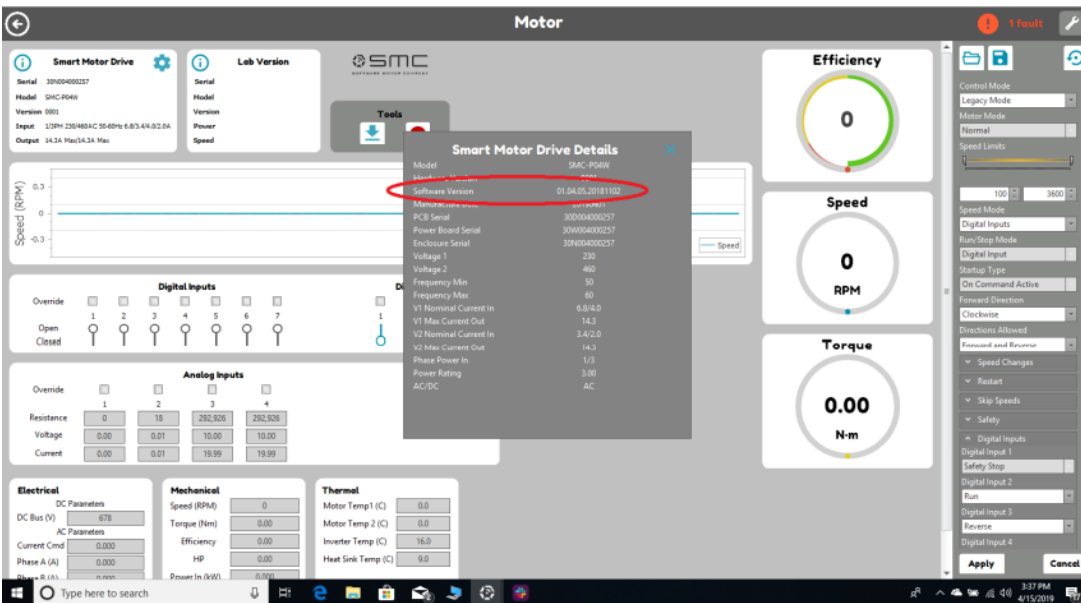

Figure 15 Motor Controller Information with Firmware (Software version)



Upgrading the Motor Controller Firmware



Warning: The motor controller Wi-Fi chip cannot be updated when connected over Modbus. It is recommended to update the motor controller over Wi-Fi only.

To upgrade the motor controller firmware:

1. In the **Motor** main control screen, click the **Download (arrow)** symbol in the **Tools** section.
2. In the file selection popup window of your Windows PC, point to the firmware file to upgrade. *The file name displayed in the screenshot is only an example.*
3. Click **Open**.
4. Follow the onscreen instructions to complete the firmware upgrade.

The motor controller will reset and restart at the conclusion of the upgrade.

Figure 16 Firmware File Selection

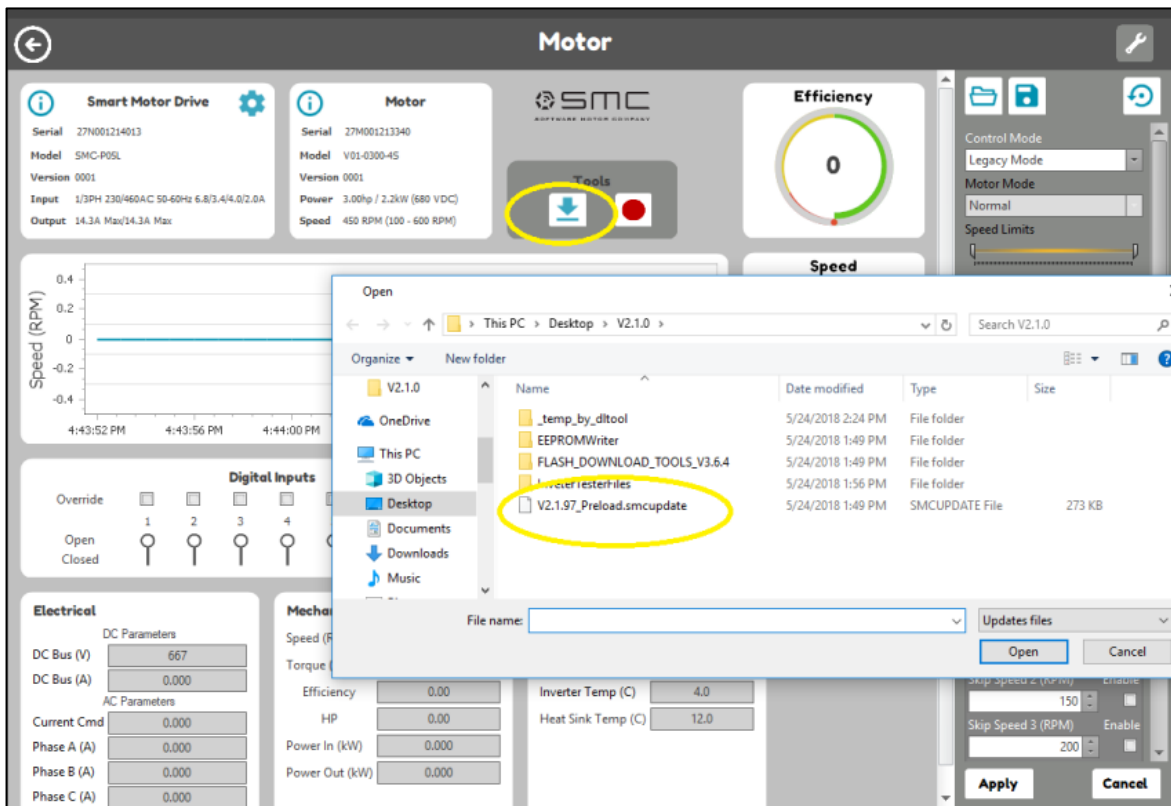

Running the Motor through the Windows PC Control Application

Figure 17 Motor Data Screen

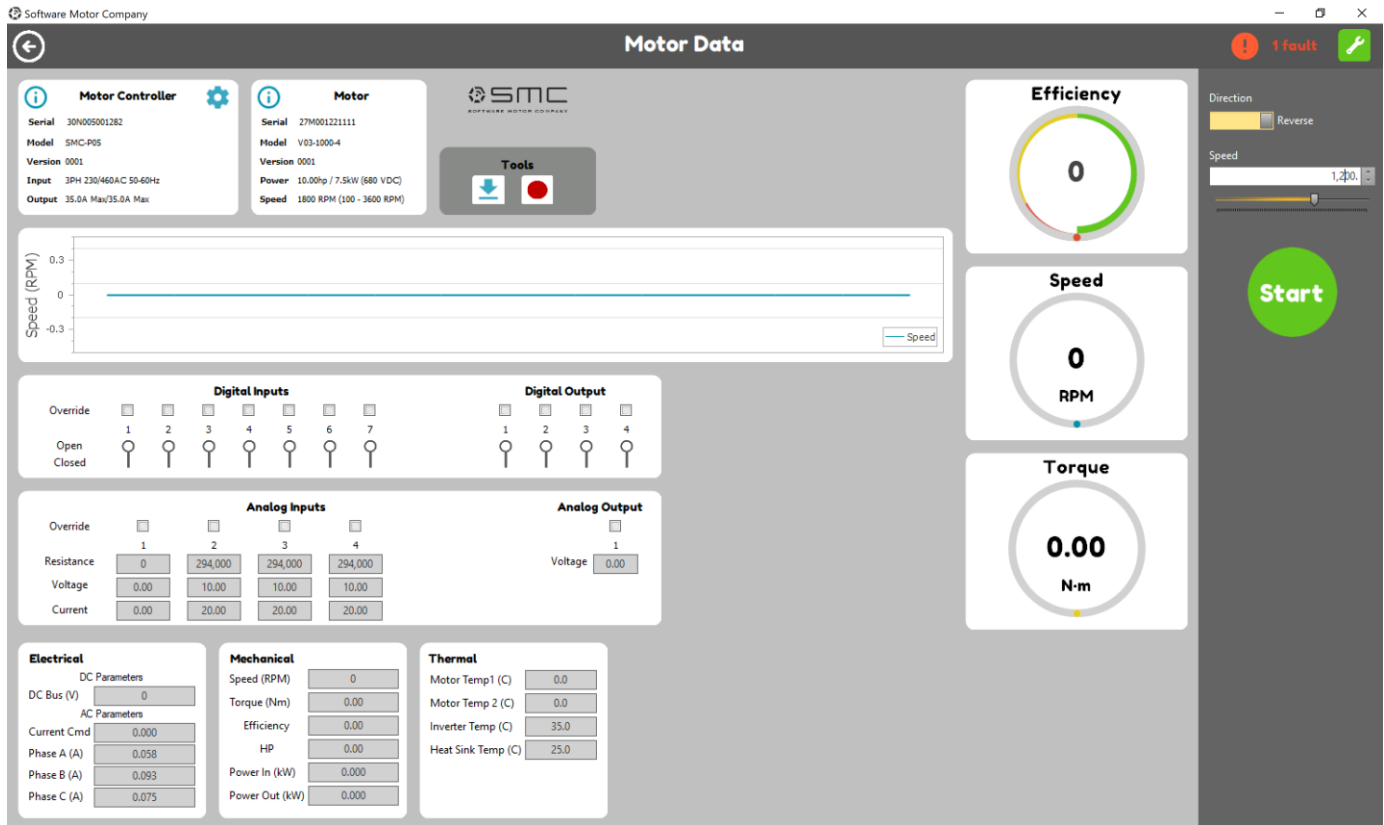

<p>Start/Stop</p>	<p>Circular toggle button. The displayed state “Start” or “Stop” indicates what will occur when the button is pressed. If Start is displayed and the button is green, pressing the button starts the motor. If Stop is displayed and the button is red, pressing the button stops the motor.</p>
<p>Direction</p>	<p>Toggles the direction of rotation to Forward or Reverse. The motor will need to come to a stop before direction can change</p>
<p>Speed</p>	<p>Sets the speed at which the motor will operate. The speed range is set to the minimum and maximum values for the connected motor. Change the requested speed by typing into the input box or dragging the slider. Typically, the motor responds immediately to speed changes. <i>Pressing Enter or clicking is not required.</i> The speed measured by the motor is shown in the display area.</p>
<p>Faults/Warnings</p>	<p>These sections display any faults or warnings active in the motor controller. Click to expand the message window and clear/reset alerts.</p>

Programming Options - 0-10Vdc, 0-20mA, 4-20mA

1. In the **Motor Data** screen, from the **Control Mode** dropdown field in the right sidebar, select **Legacy Mode**.

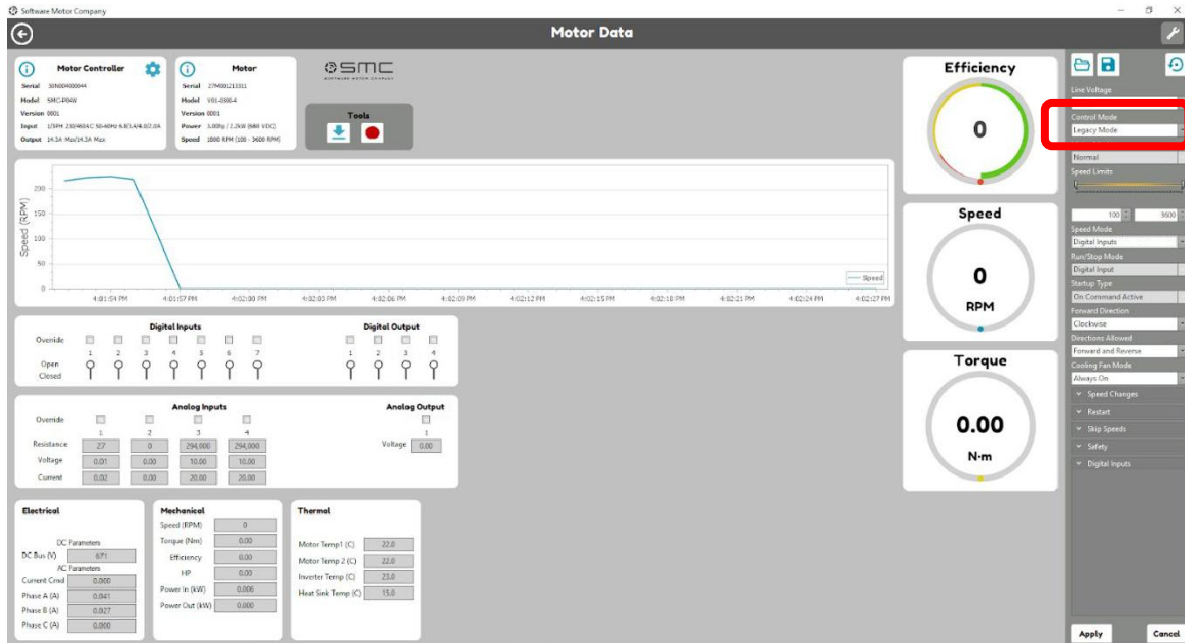

2. From the **Speed Mode** dropdown field in the right sidebar, select the appropriate mode (**Voltage 0-10V**, **Current 0-20mA**, or **Current 4-20mA**)

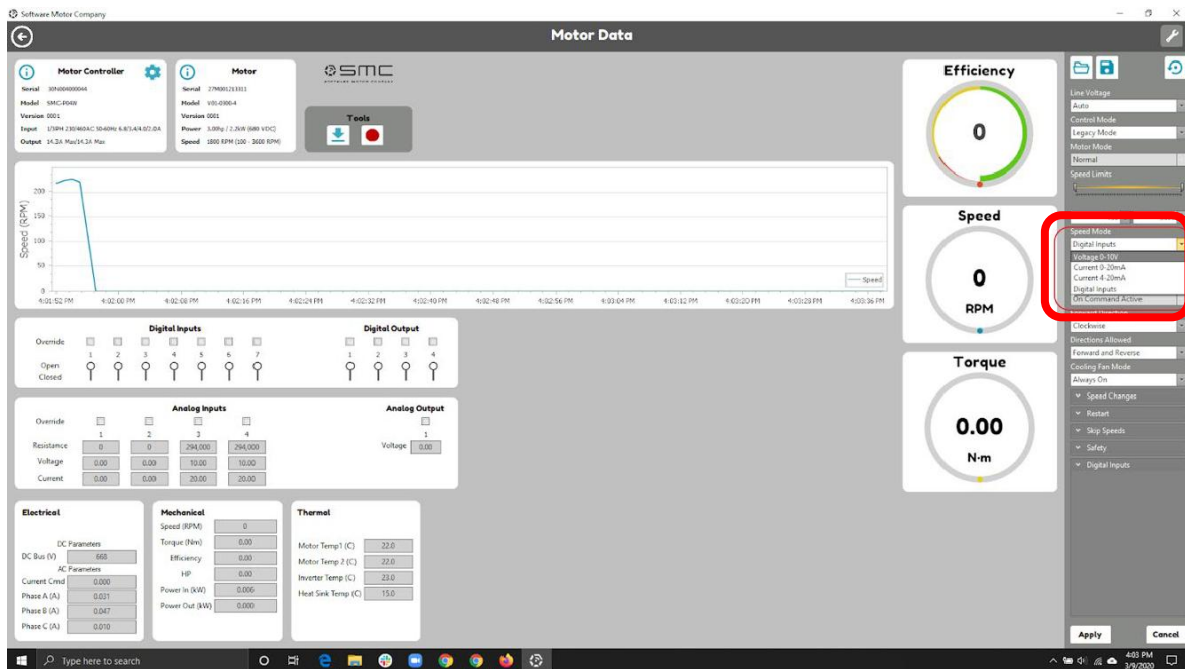

3. Click **Apply**.

How to Replace a P04/P05/SL120 with SL121/P06 Control Wiring

1. When removing the existing controller, retain the existing **BLACK** and **WHITE** wire harnesses.
2. Remove and retain the orange jumper wires that are connected to terminals **R1B, R2B, R3B, and R4B**.
3. Remove the blue wire harness from the new Turntide motor controller. *It is not used in this application.*
4. Install the orange jumper wires in the new motor controller terminals **R1B, R2B, R3B, and R4B**.
5. Connect the wires of the **BLACK** harness as follows:
 - a. Red to R1B (this is already connected to the orange jumper)
 - b. Black to COM
 - c. Yellow to R1A
 - d. Blue to R2A
 - e. White to R3A
 - f. Brown to R4A
 - g. Green to DI1 (this already connected to the green wire of the **WHITE** harness)
6. Connect the wires of the **WHITE** harness as follows:
 - a. Green to DI1 (this is already connected to the green wire of the **BLACK** harness)
 - b. Yellow to DI2
 - c. Blue to DI3
 - d. White to DI4
 - e. Brown to DI5

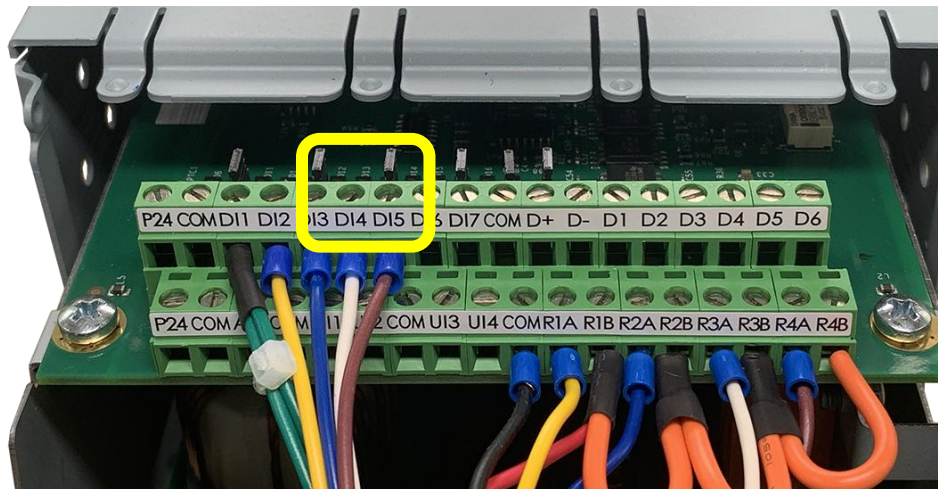

Figure 18 Older SL120 Motor Controller Showing Existing Control Wiring

