

This manual is intended for use by qualified personnel only. It is not intended to supplant HVAC or electrical safety training.



Installation Guide



Turntide Smart Motor System for AHU Applications with Pre-Wired Motors

**Document Version 2.0
January 14, 2026**

Revision History

Document Revision Number	Description	Date
2.0	Revised Wiring Information P04/P05/SL120 Added Wiring Information P06 and SL121	January 14, 2026
1.0	March 2022 Initial release of guide	March 2022

Conventions

Bold	<ul style="list-style-type: none"> • Used in procedures for names of interface elements, such as buttons, fields, and menu items. • For names of apps. • For emphasis, typically when introducing a new concept or for the adverb “NOT.” • For measurements when necessary to distinguish from surrounding text
<i>Italics</i>	References for names of additional Turntide guides and documents.
Links	Blue font for cross-references within document and to external sources.
Note:	Indicates information that can help a customer make better use of a Turntide product.
Caution icon 	Indicates an instruction that draws attention to the risk of damage to the product, process, or surroundings.
Warning icon 	Indicates an instruction that draws attention to risk of injury or death and tells the customer how to avoid the potential problem.

Legal

The information in this document is subject to change without notice and should not be construed as a commitment by Turntide Technologies® or Software Motor Company. Turntide Technologies assumes no responsibility for any errors that may appear in this document. In no event shall Turntide Technologies be liable for incidental or consequential damages arising from use of this document or the software and hardware described in this document. © Turntide Technologies. All rights reserved.

Contact

support@turntide.com | 11720 Amber Park Drive, Suite 160, Alpharetta, GA 30009 | www.turntide.com

Contents

Audience	5
About this Installation Guide	5
Control Wiring.....	5
Tools You'll Need.....	6
Included Items.....	7
Box 1: Turntide Smart Motor	7
Box 2: Turntide Smart Motor Controller	9
Box 3: Turntide Motor Systems Installation Kit.....	11
Box 4: Motor Noise Isolation Feet Installation Kit	12
Installation Instructions in an AHU	13
Task 1: Uninstall the Existing Motor and Install the Turntide Motor	13
Task 2: Confirm Motor Controller Configuration.....	16
Jumper Pins (P04, P05, and SL120 Motor Controllers)	17
SL121 Motor Controller Switches.....	19
SL121 Motor Controller User-Selectable Switch Options Usage &.....	20
P06 Motor Controller Switch Options	22
Task 3: Install the Turntide Motor Controller	26
Task 4: Wire Components	29
Task 5: Start Up the System	34
Wiring Information P06 and SL121.....	36
Constant Volume AHU or Controlled by Thermostat on Control Board: SL121 Motor Controllers, Monitor Only	36
Constant Volume AHU or Controlled by Thermostat on Control Board: Wiring Information P06 Motor Controllers, Monitor Only	37
P06 & SL12: Single Speed – Single Start/Stop Signal	38
P06 & SL12: Multi Speed – Multi Start/Stop Signals.....	39
P06 & SL12: 0-10V / 2-10V plus Start/Stop Signal	40
P06 and SL121: 0-20mA / 4-20mA plus Start/Stop Signal	41
Wiring Information P04/P05/SL120	42
P04/P05/SL120 Single Speed – Single Start/Stop Signal.....	42
P04/P05/SL120 Multi Speed- Multi Start/Stop Signals.....	43
P04/P05/SL120 - 0-10V / 2-10V plus Start/Stop	44

P04/P05/SL120 - 0-20mA / 4-20mA plus Start/Stop Signal	45
Appendix	46
How to Install Noise Isolation Feet	46
Installation Steps	47
KIT-ISLN-FT-101 Motor Noise Isolation Feet Installation on V01 and V02 Motors, Frames A, C, and D..	48
KIT-ISLN-FT-201 Motor Noise Isolation Feet Installation on V01 and V02 Motors, Frame F	51
KIT-ISLN-FT-301 Motor Noise Isolation Feet Installation on V03 Motors, Frame H	54
Special Instructions for Installation on a Vertical Mounting Plate	57
Key Concepts	57
Special Case: Replacing Old Turntide Motor Controller with a P06 or SL121 Motor Controller	62
How to Replace a P04/P05/SL120 with SL121/P06 Control Wiring.....	62
Best Practices for Installing Belt	63
Fan Pulley and Motor Pulley Alignment.....	65
Troubleshooting a Stalled Motor	66
Supply and Return Air Sensors.....	66

Audience

The instructions in this guide are intended for a mechanical technician who is familiar working with commercial air handling units (AHUs).

You will have access to Support from Turntide Technical Services: <https://support.turntide.com/>



Required: Follow all local and national electrical codes, safety compliance requirements, and common installation procedures.

About this Installation Guide

This guide provides instructions on how to install and set up the Turntide Motor System, consisting of the Turntide Smart Motor and the Turntide Motor Controller. The contents of kits and recommended tools are also listed.

The following motors and motor controllers are featured in this guide:

- V series motors: V01, V02, and V03
- P06 series motor controllers
- SL121 series motor controllers





Control Wiring

Important: If you are replacing an existing Turntide Motor Controller (P04, P05, SL120) with an SL121 or P06, you will notice that the pre-wiring scheme has changed. **The SL121 and P06 motor controllers are prewired with a blue input cable.**

- **P06 and SL121 controllers are intended for Monitor Only integration.**
- If you do not wish to use the new Monitor Only control wiring method but want to maintain the Full Integration control wiring, you **MUST** use the existing wiring harness. See [Special Case: Replacing Old Turntide Motor Controller with a P06 or SL121 Motor Controller](#).

Tools You'll Need

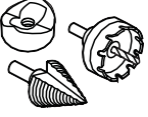
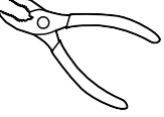
Table 1 Tools List

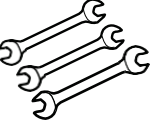
 <p>Belt tension gauge</p>	 <p>Uni-bit, hole sawor knock outs (for drilling hole into the AHU for the external unit antenna) 7/8in bit</p>	 <p>Drill bit index up to 1/2in</p>	 <p>Wheel puller 3-jaw for removing existing motor pulley</p>
		 <p>Cordless drill</p>	 <p>Torque wrench</p>
 <p>Terminal (spade) crimp tool</p>	 <p>Wire strippers</p>	 <p>Multi-VOM meter</p>	 <p>Clamp amp meter</p>
 <p>Adjustable pliers</p>	 <p>Needle nose pliers</p>	 <p>Hex wrenches 2mm and 5mm</p>	 <p>Hex wrench set 1/8in - 3/8in</p>
 <p>Screwdriver Phillips</p>	 <p>Screwdriver slot</p>	 <p>Screwdriver, small terminating</p>	 <p>Nut driver 1/4in and 5/16in</p>
 <p>Combo Box/Open-End wrenches up to 3/4in Ratcheting type recommended.</p>	 <p>Thin head access wrenches</p>	 <p>90-degree offset wrenches</p>	<p>Additional supplies:</p> <ul style="list-style-type: none"> • Silicon caulk • Retaining compound • Degreaser





Included Items

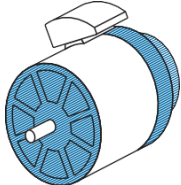
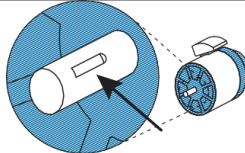

Everything typically required to install the Turntide Smart Motor System arrives in separate boxes:

- Box 1: Turntide Smart Motor
- Box 2: Turntide Motor Controller
- Box 3: Turntide Motor Systems (AHU) Installation Kit
- Box 4: Motor Noise Isolation Feet Installation Kit (*may not be included in your installation*)

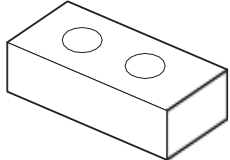

Note: Not all components in a kit will be used on every installation. Also, for unique applications, additional supplies may be required.

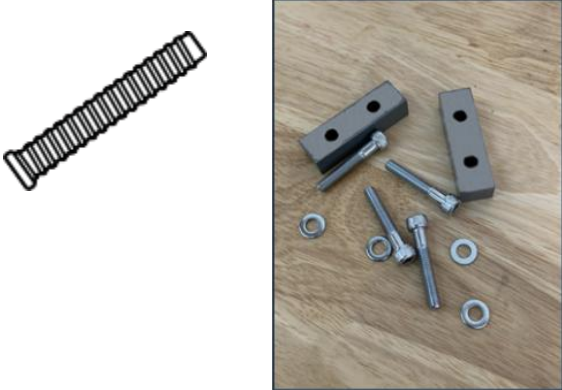
Box 1: Turntide Smart Motor

Item	Quantity
Turntide motor Use appropriate equipment and ensure safe handling when moving/lifting motors. For motor weights, see the Quick Reference Guide on https://support.turntide.com/	 1
Shaft Adapter & Key (included only V01 Frame C motors)	 1
 Caution: Motor power harnesses are rated to 600 V and the Turntide controller and motor nameplates indicate operation up to 680 V.	1
Power cable Voltage rating on power cabling is AC voltage and any reference to 680 V is DC. <ul style="list-style-type: none"> • 600 VAC cable is acceptable to hold 680 VDC • 230 VAC solutions may reference up to 340 VDC • 460 VAC solutions may refer up to 680 VDC • 575 VAC solutions may refer up to 850 VDC 	 1
Feet spacers supplied with V01 and V02-D motors, which allow for better wrench access. (Do NOT use with noise isolation feet.) <div style="display: flex; justify-content: space-around; align-items: flex-start;">    </div>	2

Item	Quantity
<p data-bbox="142 193 1182 226">Bolts for feet spacers supplied with V01 and V02-D motors (M6 x 1mm x 25 mm)</p> 	<p data-bbox="1377 193 1409 226">4</p>
<p data-bbox="142 701 766 852">Mounting plate bolt sleeves (5/16in x 9/16in x 3/8in) supplied with V01 and V02 motors, which allows uniform tightening of the nut. (Do NOT use with noise isolation feet.)</p> 	<p data-bbox="1377 701 1409 735">4</p>

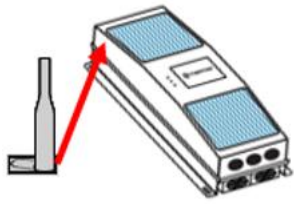
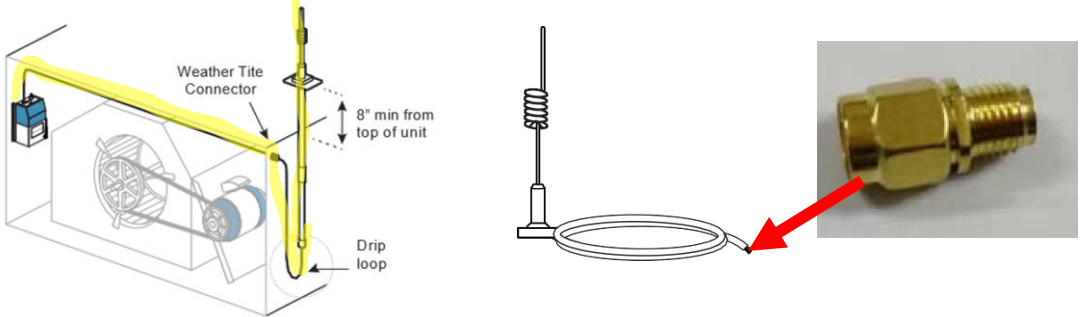
Box 2: Turntide Smart Motor Controller

Item	Quantity
<p data-bbox="138 254 987 285">Small antenna pre-installed on P06 and SL121 motor controllers</p> <div data-bbox="537 312 902 520">  <p data-bbox="850 491 902 520">P06</p> </div> <p data-bbox="138 604 342 636">Two Scenarios:</p> <ol data-bbox="188 682 1281 1066" style="list-style-type: none"> <li data-bbox="188 682 1281 793"> <p data-bbox="188 682 948 714">1. New installation of Turntide motor system at the site:</p> <p data-bbox="233 720 1281 793">The small antenna is pre-installed on the P06 and SL121 motor controllers, so no further action is required for these models.</p> <li data-bbox="188 837 1281 1066"> <p data-bbox="188 837 1281 949">2. You are replacing an existing Turntide motor controller (for example, P04, P05, or SL120) with a newer motor controller (for example, P06 or SL121) AND you already have an RMK installed:</p> <p data-bbox="233 955 1281 1066">You will use the existing External Dual-Band Wi-Fi antenna with 3m wire that is already wired through the AHU (for RMK) and attach it to the P06 or SL121 using the coaxial connector adapter that is provided.</p> <div data-bbox="203 1066 1281 1381">  </div> <p data-bbox="138 1430 1190 1503">Cord Grip Kit (or fittings already attached to blue cable) for SL121 and P06 motor controllers for wi-fi antenna riser associated with RMK. 1 Kit</p> <div data-bbox="607 1503 935 1942">  </div>	<p data-bbox="1386 254 1409 285">1</p>

(Pre-wired) Motor Controller and Control Cables

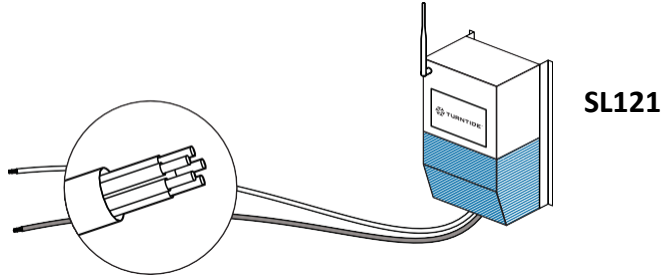

**1 Motor
Controller
and
cable(s)**



Turntide Motor Controller models are available for different motor configurations. Their installation is described in this guide.

The SL121 and P06 motor controllers are prewired with a blue input cable, 600 V rating.

All cables provided by Turntide are NOT rated for outdoor use.

Box 3: Turntide Motor Systems Installation Kit

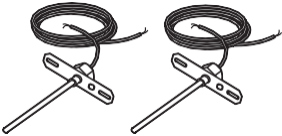
Item	Quantity
Wire nuts – tan and red for motor power cable 	6 of each
Wire nuts – blue for thermostat 	8
Hex head screws #10 x ¾ in 	6
Cable ties, 8 in 	10
Snap-in bushing – ½ in 	6
Snap-in bushing – ¾ in 	6
Snap-in bushing – 1 ¼ in 	2
Washer for #10 screw, ¼in ID and 9/16 inch OD 	4
Cable tie holder, center mount 	6

Item	Quantity
<p>May arrive in a separate box. Air temp sensors and a 10-inch wire included if applicable. Sensor appearance may vary.</p> 	2
<p>Turntide and Caution labels</p> 	1 each

Box 4: Motor Noise Isolation Feet Installation Kit

May not be required on every motor installation.

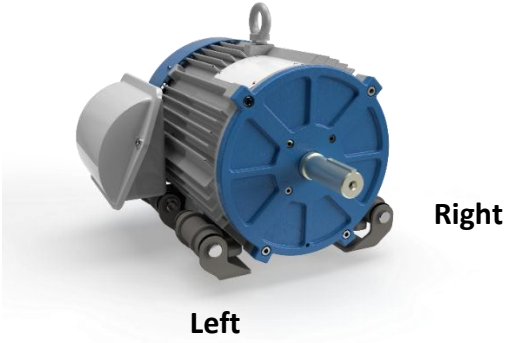
<p>KIT-ISLN-FT-101 Motor Noise Isolation Feet Installation on V01 and V02 Motors, Frames are A, C, D KIT-ISLN-FT-201 Motor Noise Isolation Feet Installation on V01 and V02 Motors, Frame F KIT-ISLN-FT-301 Motor Noise Isolation Feet Installation on V03 Motors, Frame H</p> <p>Example of V01 motor with noise isolation feet KIT-ISLN-FT-101 installed.</p>  <p>See Noise Isolation Feet Installation instructions.</p>	1 Kit
--	--------------

Installation Instructions in an AHU

Follow these simple step-by-step instructions to replace the existing motor in a common Air Handling Unit (AHU) with a new Turntide Smart Motor System.

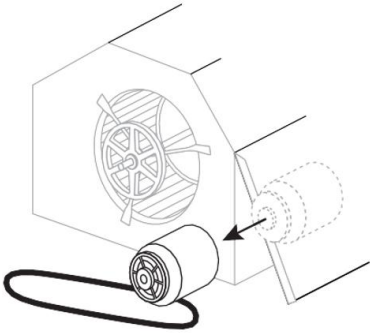

Task 1: Uninstall the Existing Motor and Install the Turntide Motor

Step	Instructions for Task 1: Uninstall the existing motor and Install the Turntide Motor	
1	Isolate all incoming power to AHU unit using normal Lock Out/Tag Out and local code requirements and verify that all power is turned off to the unit.	
2	1. Remove the existing belt. 2. Remove the motor and mounting plate as one assembly. In most cases, it's easier to remove the motor pulley before removing the motor.	

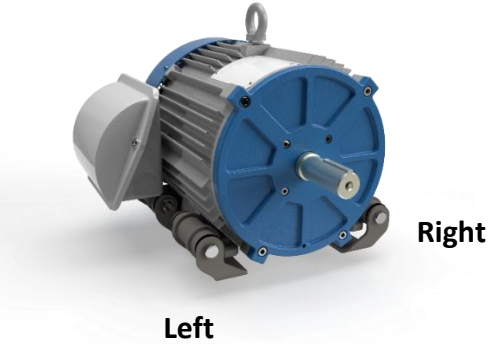
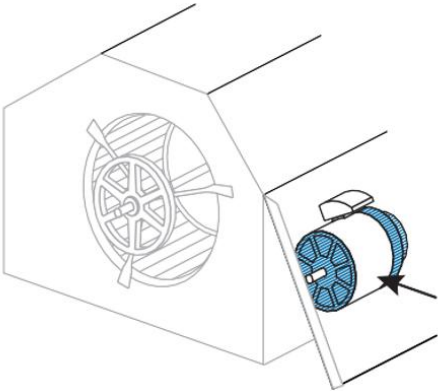
Step	Instructions for Task 1: Uninstall the existing motor and Install the Turntide Motor	
<p>3</p> <p>Determine if you should install the Noise Isolation Feet to the base of the new motor. Consider the following points:</p> <ol style="list-style-type: none"> Noise isolation feet increase the overall height of the Turntide motor as follows: <ul style="list-style-type: none"> KIT-ISLN-FT-101 on a V01 motor raises the shaft height 0.5 inches (1.27 cm) KIT-ISLN-FT-101 on a V02-D motor raises the shaft height 0.5 inches (1.27 cm) KIT-ISLN-FT-201 on a V02-F motor raises the shaft height 0.125 inches (0.32 cm) KIT-ISLN-FT-301 on a V03 motor raises the shaft height 0.62 inches (1.57 cm) You may have to increase the size of the belt once the isolator feet are installed. It takes more time to complete the installation when you add noise isolation feet. Is the the location where you are installing the motor a noise-sensitive area and therefore requires noise isolation feet? <p>YES, to installing noise isolation feet? Follow the instructions in the Appendix of this guide at this point in your installation process.</p>	<p>Example of V01 motor with noise isolation feet KIT-ISLN-FT-101 installed.</p>  <p>Left</p> <p>Right</p> <ol style="list-style-type: none"> KIT-ISLN-FT-101 Motor Noise Isolation Feet Installation on V01 and V02 Motors, Frames are A, C, D KIT-ISLN-FT-201 Motor Noise Isolation Feet Installation on V01 and V02 Motors, Frame F KIT-ISLN-FT-301 Motor Noise Isolation Feet Installation on V03 Motors, Frame H 	
<p>4</p> <p>Install the Turntide Smart Motor to the existing motor mounting plate.</p>		

Step	Instructions for Task 1: Uninstall the existing motor and Install the Turntide Motor	
5	<p>In some cases, tightening the motor plate nut is not possible. The bolt sleeves provided allow for proper nut tightening.</p>	
6	<p>For V01 Frame C motors ONLY. The Turntide V01 Frame C motor has a 5/8in shaft, and the existing motor pulley is 7/8in ID.</p> <p>You must install the shaft adapter as follows:</p> <ol style="list-style-type: none"> 1. Clean the shaft with a degreaser. 2. Apply a small amount of Loctite 620 retaining compound. 3. Install the shaft adapter with the set screw towards the shaft end. 4. Insert the extended height shaft key and tighten the set screw to lock the shaft adapter in place. 	
7	<p>Reinstall original motor pulley. If the existing pulley shows signs of excessive wear, it should be replaced. Replacing worn components will ensure that the system is running most efficiently.</p> <p>See also: Fan Pulley and Motor Pulley Alignment</p>	
8	<p>Install the belt. Use the recommended visual step-by-step process in Best Practices for Installing Belt.</p>	

Task 2: Confirm Motor Controller Configuration

Turntide motor controllers are designed for several applications. The jumpers and switches are used to configure the motor controller for a specific application.

Before connecting the controller to the Turntide motor, verify the controller configuration.

- [Jumper Pins \(P04, P05, and SL120 Motor Controllers\)](#)
- [SL121 Motor Controller Switches](#)
- [P06 Motor Controller Switch Options](#)

Important: If you are replacing an existing Turntide Motor Controller (P04, P05, SL120) with an SL121 or P06, you will notice that the pre-wiring scheme has changed. **The SL121 and P06 motor controllers are prewired with a blue input cable.**

- **P06 and SL121 controllers are intended for Monitor Only integration.**
- If you do not wish to use the new Monitor Only control wiring method but want to maintain the Full Integration control wiring, you **MUST** use the existing wiring harness. See [Special Case: Replacing Old Turntide Motor Controller with a P06 or SL121 Motor Controller](#).

Jumper Pins (P04, P05, and SL120 Motor Controllers)

Before connecting the controller to the Turntide motor, verify the controller configuration.

Digital Input Mode jumpers	<p>The Digital Input Mode jumpers determine the inputs the motor controller recognizes:</p> <ul style="list-style-type: none"> • Most common configuration is a jumper across pins 1&2 and another across pins 5&6. • Pins 1&2 enable the MODBUS EOL resistor. • Pins 5&6 set the motor controller to respond to 24VAC inputs.
Universal Input (UI) jumpers	<p>The Universal Input (UI) jumpers define the connected device type:</p> <ul style="list-style-type: none"> • Currently UI3 and UI4 are used in applications with Supply and Return Air sensors. • Setting the respective jumpers across pins 1 & 2 configure the control to respond to the resistive load of the thermistor.

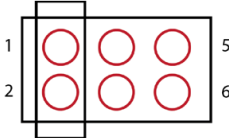
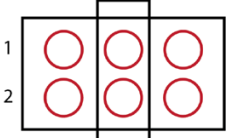
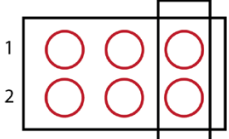
 Input mode selection must be jumpers 1&2 and 3&4 <u>or</u> 1&2 and 5&6.						
Motor Controller Model	Modbus EOL Jumper	Digital Input Mode Jumper	Universal Input Mode Jumpers			
			UI1	UI2	UI3	UI4
P04W	J96	J96	J5125	J111	J112	J113
P05	J96	J96	J5125	J111	J112	J113
SL120	J10	J10	J11	J12	J13	J14
Modbus EOL Selection						
Pin Selections		Mode			Examples	
1 & 2 		Installed: Enables EOL Resistor (End of line) Removed: Disables EOL Resistor (End of line)			Install if wiring to terminals D+/D- is end of daisy chain.	
Digital Input Mode Selection						
Pin Selections		Mode			Examples	
3 & 4 		Enables digital inputs LOGIC or dry contact mode.			Install if S1 through S7 will be used to receive contact closures for control.	
5 & 6 		Enables digital inputs 24VAC signaling mode.			Install if S1 through S7 will be used to receive 24VAC input signal from existing BMS or thermostat.	

Universal Input Mode Selection		
Pin Selections	Mode	Examples
1 & 2 	Resistive/LOGIC: Returns resistance of connected element or ON/OFF if declared as resistive or LOGIC mode respectively.	Resistive: 2 wire 10K Ω thermistor LOGIC: Dry contact closure = ON Dry contact open = OFF
3 & 4 	Voltage: 0-10V signal ended voltage input.	3-wire device with external power source that provides 0-10V signal. (1 signal, 1 common, 1 power)
5 & 6 	Current: 0-20mA current input.	3-wire device with external power source that provides a 0-20mA signal. (1 signal, 1 common, 1 power)

To ensure the motor controller jumper pins are set correctly for an AHU installation, consult the following:

Table 2 Motor Controller Jumper Pins (Image rotated 90 degrees)

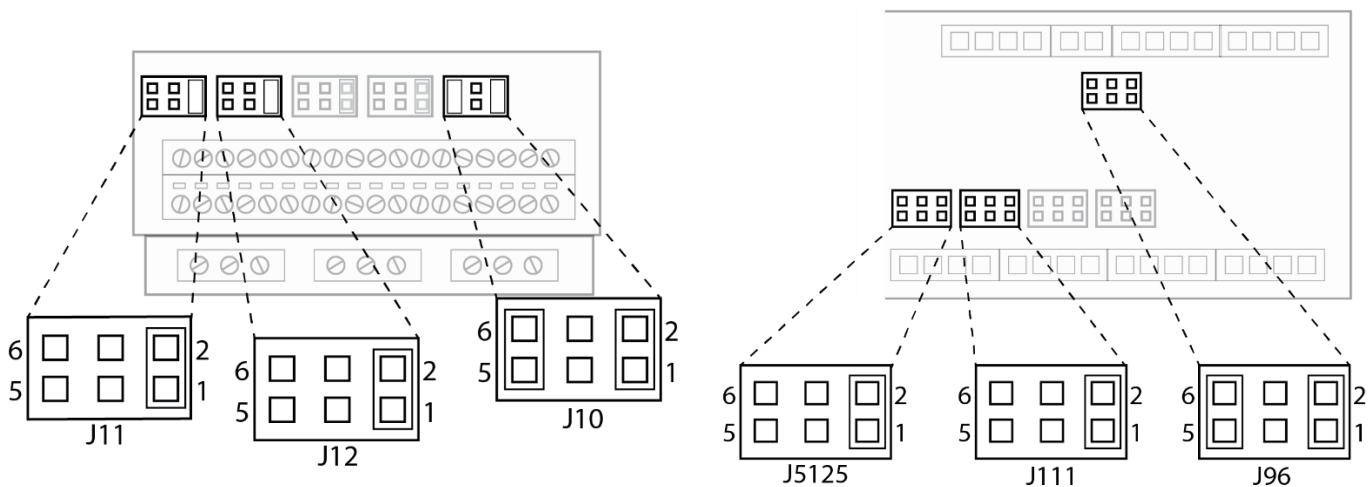

SL120 Motor Controller Jumper Pins

- Confirm J11 and J12 jumper bridges are set on pins 1&2.
- Confirm J10 jumper bridges are set on pins 1&2 and 5&6.

P05 Motor Controller Jumper Pins

- Confirm J5125 jumper bridges are set on pins 1&2.
- Confirm J111 bridges are set on 1&2 and J96 bridges on pins 1&2 and 5&6.

SL121 Motor Controller Switches

Figure 1 User-Selectable Switches SL121

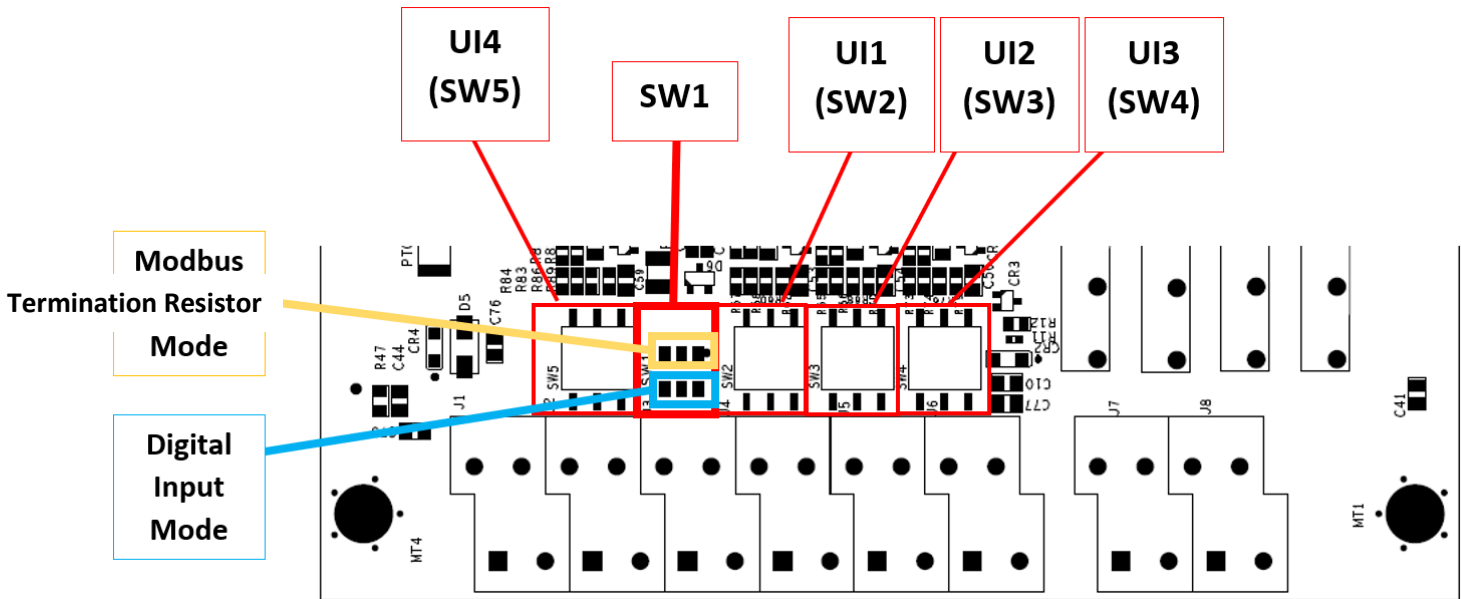

SW1 for Modbus Termination Resistor and Digital Input Mode

SW1 is used for both the Modbus Termination Resistor and Digital Input Mode settings selection. Digital or Discrete Inputs initiate a programmed response of the motor controller based on parameter settings.

UI1 to UI4

Universal inputs define the connected device type. The Universal inputs may be configured in one of **three modes (I, V, R)** via DIP Switches.

- **Voltage (V):** 0-10V (may be used to control the inverter directly or used to monitor CO2 or other sensors in HVAC systems)
- **Current (I):** 0-20mA or 4-20mA (may be used for direct current loop control of the motor controller)
- **Resistive (R):** Thermistor temperature sensors (may be used to monitor ambient air, return air, and supply air temperatures in HVAC systems)

Notes:

- Position 1 ON is the **resistive mode**
- Position 2 ON is the **voltage mode**
- Position 3 ON is the **current mode**.



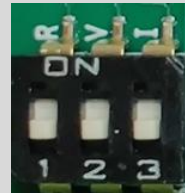

ONLY one switch position should be ON at a time.

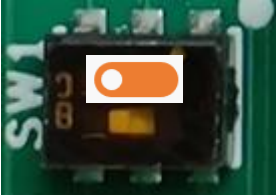
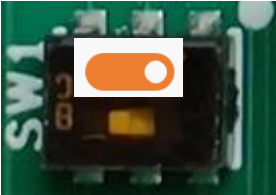
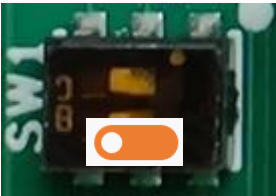
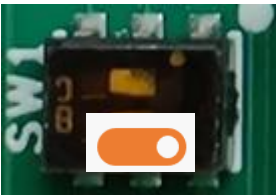

SL121 Motor Controller User-Selectable Switch Options Usage & Example

Table 3 Switch Options SL121

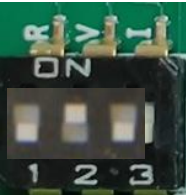
Motor Controller Model	Modbus Termination Resistor Switch	Digital Input Mode Switch	Universal Input Mode Switches			
			UI1	UI2	UI3	UI4
SL121	SW1	SW1	SW2	SW3	SW4	SW5
Modbus Termination Resistor Selection						
Switch Position		Mode			Examples	
Top LEFT position 		Modbus termination resistor is enabled			Set if wiring to terminals D+/D is end of daisy chain.	
Top RIGHT position 		Modbus termination resistor is disabled				
Digital Input Mode Selection						
Switch Position		Mode			Examples	
Bottom LEFT position 		Enables digital inputs LOGIC or dry contact mode.			Set if DI1 through DI7 will be used to receive contact closures for control.	
Bottom RIGHT position 		Enables digital inputs 24VAC signaling mode.			Set if DI1 through DI7 will be used to receive 24VAC input signal from existing BMS or thermostat.	

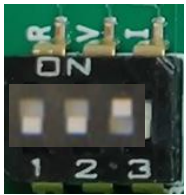
Motor Controller Model	Modbus Termination Resistor Switch	Digital Input Mode Switch	Universal Input Mode Switches			
			UI1	UI2	UI3	UI4
SL121	SW1	SW1	SW2	SW3	SW4	SW5
Universal Input Mode Selection						
UI1 to UI4 DIP Switch ON		Mode			Examples	
<p> Caution: ONLY one switch position should be ON at a time; otherwise, may cause damage to the motor controller.</p> <p>R</p> 		<p>Resistive/LOGIC: Returns resistance of connected element or ON/OFF if declared as resistive or LOGIC mode respectively.</p>			<p>Resistive: 2 wire 10K Ω thermistor</p> <p>LOGIC: Dry contact closure = ON Dry contact open = OFF</p>	
<p> Caution: ONLY one switch position should be ON at a time; otherwise, may cause damage to the motor controller.</p> <p>V</p> 		<p>Voltage: 0-10V signal ended voltage input.</p>			<p>3-wire device with external power source that provides 0-10V signal. (1 signal, 1 common, 1 power)</p>	
<p> Caution: ONLY one switch position should be ON at a time; otherwise, may cause damage to the motor controller.</p> <p>I</p> 		<p>Current: 0-20mA current input.</p>			<p>3-wire device with external power source that provides a 0-20mA signal. (1 signal, 1 common, 1 power)</p>	

P06 Motor Controller Switch Options

Universal inputs define the connected device type. The Universal inputs may be configured in one of **three modes (I, V, R)** via DIP Switches.

- **Voltage (V):** 0-10V (may be used to control the inverter directly or used to monitor CO2 or other sensors in HVAC systems)
- **Current (I):** 0-20mA or 4-20mA (may be used for direct current loop control of the motor controller)
- **Resistive (R):** Thermistor temperature sensors (may be used to monitor ambient air, return air, and supply air temperatures in HVAC systems)

Notes:

- Position 1 ON is the **resistive mode**
- Position 2 ON is the **voltage mode**
- Position 3 ON is the **current mode**.



ONLY one switch position should be ON at a time.

SW7 for Modbus Termination Resistor and Digital Input Mode

SW7 is used for both the Modbus Termination Resistor and Digital Input mode settings selection. Digital or Discrete Inputs initiate a programmed response of the motor controller based on parameter settings.

The blue D+ D- cap is easily removed to improve access to SW7.

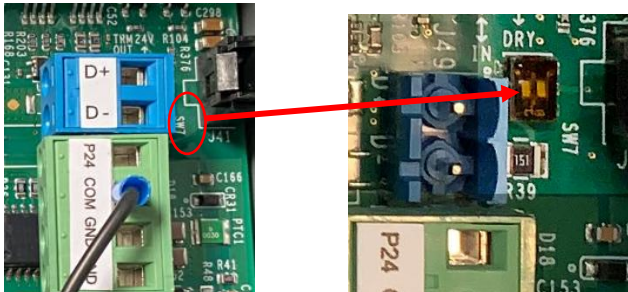

P06 Motor Controller User-Selectable Switch Options Diagram

Figure 2 User-Selectable Switches P06

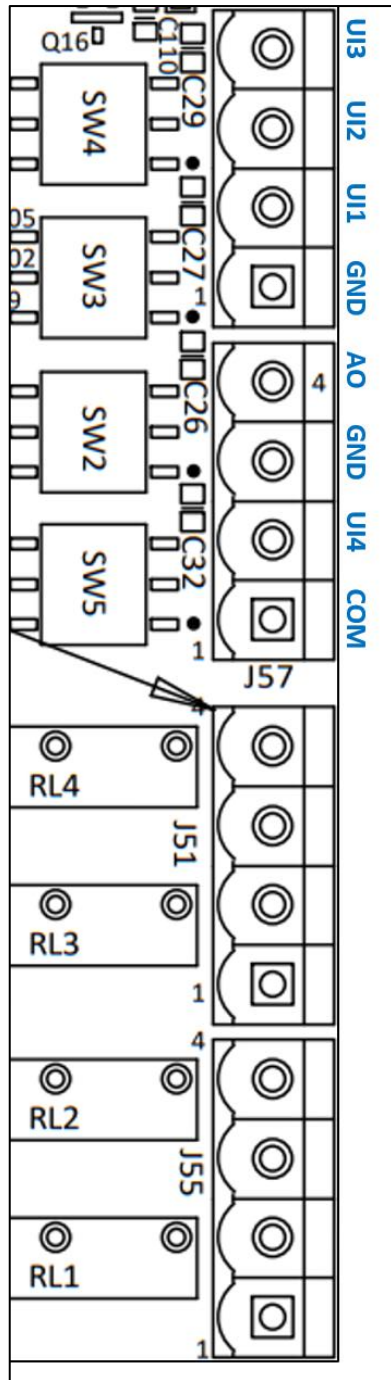

- UI3 (SW4)
- UI2 (SW3)
- UI1 (SW2)
- UI4 (SW5)

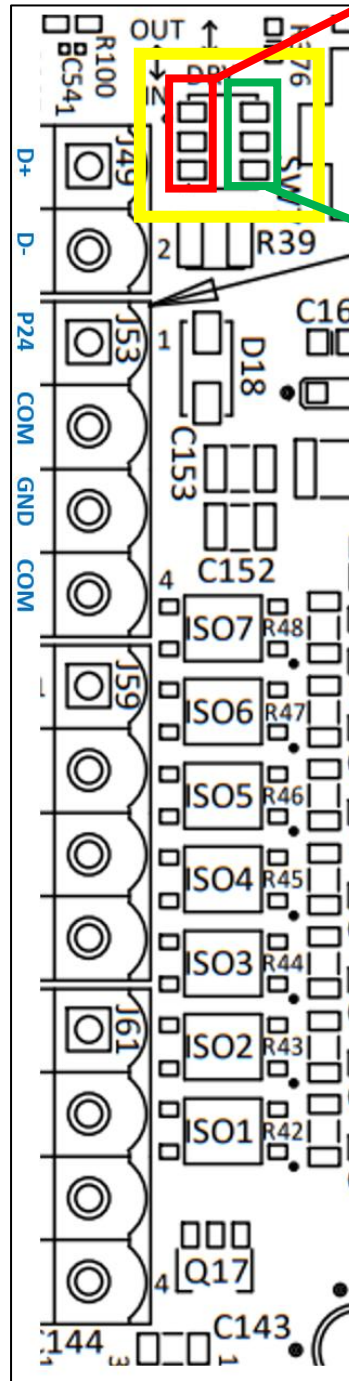









SW7: Modbus Termination Resistor Mode

SW7: Digital Input Mode

P06 Motor Controller User-Selectable Switch Options Usage & Examples

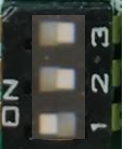
Table 4 P06 User-Selectable Switch Options

Motor Controller Model	Modbus Termination Resistor Switch	Digital Input Mode Switch	Universal Input Mode Switches			
			UI1	UI2	UI3	UI4
P06	SW7	SW7	SW2	SW3	SW4	SW5
Modbus Termination Resistor Selection						
Switch Position		Mode	Examples			
Left DOWN position 		Modbus termination resistor is enabled	Set if wiring to terminals D+/D is end of daisy chain.			
Left UP position 		Modbus termination resistor is disabled				
Digital Input Mode Selection						
Switch Position		Mode	Examples			
Right DOWN position 		Enables digital inputs LOGIC or dry contact mode.	Set if DI1 through DI7 will be used to receive contact closures for control.			
Right UP position 		Enables digital inputs 24VAC signaling mode.	Set if DI1 through DI7 will be used to receive 24VAC input signal from existing BMS or thermostat.			

Motor Controller Model	Modbus Termination Resistor Switch	Digital Input Mode Switch	Universal Input Mode Switches			
			UI1	UI2	UI3	UI4
P06	SW7	SW7	SW2	SW3	SW4	SW5
Universal Input Mode Selection						
UI1 to UI4 DIP Switch ON		Mode		Examples		
 Caution: ONLY one switch position should be ON at a time; otherwise, may cause damage to the motor controller. R 		Resistive/LOGIC: Returns resistance of connected element or ON/OFF if declared as resistive or LOGIC mode respectively.		Resistive: 2 wire 10K Ω thermistor LOGIC: Dry contact closure = ON Dry contact open = OFF		
 Caution: ONLY one switch position should be ON at a time; otherwise, may cause damage to the motor controller. V 		Voltage: 0-10V signal ended voltage input.		3-wire device with external power source that provides 0-10V signal. (1 signal, 1 common, 1 power)		
 Caution: ONLY one switch position should be ON at a time; otherwise, may cause damage to the motor controller. I 		Current: 0-20mA current input.		3-wire device with external power source that provides a 0-20mA signal. (1 signal, 1 common, 1 power)		

Task 3: Install the Turntide Motor Controller

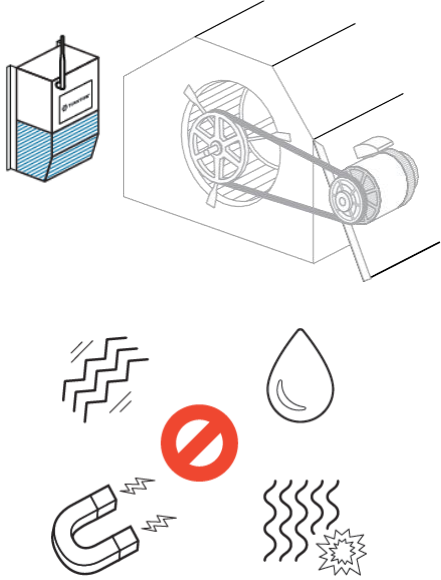
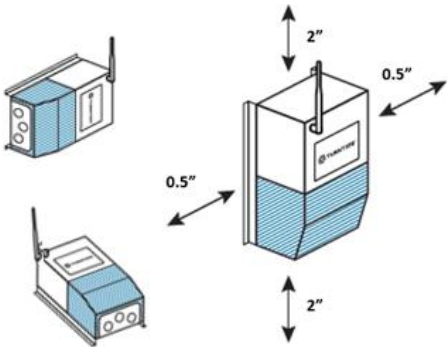

Required: Ensure that motor controller wires are isolated by a minimum of 6mm or 0.25 in from power cables and never route them through a common conduit or cable tray.

Step	Instructions for Task 3: Install the Turntide Motor Controller	
<p>1</p>	<p>Mount the Turntide Motor Controller inside the AHU—ideally in the blower cabinet—using caution not to penetrate the cabinet with the screws. Ensure the controller is far from excessive vibration, moisture, electromagnetic interference, and explosive/corrosive vapors.</p> <p>Note: If a suitable location is NOT available, please contact Turntide Technical Services.</p> <p>Do NOT install the controller on the floor in an area where pooled water or splashing water will affect it. You may have to install a channel slot (Unistrut or a similar riser) to elevate the controller so it is not in the lowest part of the cabinet where moisture can build up.</p>	
<p>2a</p>	<p>SL121 Motor Controller</p> <p>Turntide smart motor controllers ship with cable fittings (cord grips) to seal or to provide strain relief to the terminals in which the conductors are connected.</p> <p>If your controller arrives with the cable fittings already installed, complete the controller installation as follows:</p> <ol style="list-style-type: none"> 1. Mount in an upright (vertical), sideways (horizontal), or flat position to/on a rigid surface. 2. Securely attach the motor controller to the surface with a 1/4in or M7 fastener using the four screw tabs on the base. 3. The SL121 motor controller has an integrated heatsink fan shroud. We strongly recommend a minimum of: 	 <p>Note: If your business/organization requires that you manually disable Wi-Fi, please contact Turntide Technical Services for instructions.</p>

Step	Instructions for Task 3: Install the Turntide Motor Controller	
	<ul style="list-style-type: none"> • 2 inches clearance at the top and bottom of the controller to prevent impeding the airflow path • 0.5 inches around the sides of the controller to allow the inside ambient to vent. <p>If your controller does NOT have the cable fittings already installed, complete the controller installation as follows:</p> <p>The blue cable in the pre-wired controllers is coiled inside the unit. You will route the cable through the fitting and secure the fastening washer to clamp to the conduit ingress plate or plane:</p> <ul style="list-style-type: none"> • Install all strain relief accessories into the open holes with locknut on the inside. • Loosen the external portion of the strain relief (that you intend to pass the cable through) to allow for cable passage. • Uncoil the pre-wired cable and pass it through the strain relief from the inside of the enclosure to the outside of the enclosure. <ol style="list-style-type: none"> 1. Tighten the external portion of the strain relief until the internal strain relief-fitting seals and holds the cable secure. 2. Hand-tighten until it is secure and the cable no longer moves when pulled. Do NOT overtighten. 3. Mount in an upright (vertical), sideways (horizontal), or flat position to/on a rigid surface. 4. Securely install the motor controller to the surface with a 1/4in or M7 fastener using the four screw tabs on the base. 5. The SL121 motor controller has an integrated heatsink fan shroud. We strongly recommend a minimum of: <ul style="list-style-type: none"> ○ 2 inches clearance at the top and bottom of the controller to prevent impeding the airflow path ○ 0.5 inches around the sides of the controller to allow the inside ambient to vent. 	

2b
P06 Motor Controller

Turntide smart motor controllers ship with cable fittings (cord grips) to seal or to provide strain relief to the terminals in which the conductors are connected.

If your controller arrives with the cable fittings already installed, complete the controller installation as follows:

1. Mount the controller (ideally) in an upright (vertical), sideways (horizontal), or flat position to/on a rigid surface with a minimum clear space of 3 inches on top and bottom.
2. Note that there is no minimum clearance on the sides.

If your controller does NOT have the fittings already installed, complete the installation as follows:

The **blue** cable in the pre-wired controllers is coiled inside the unit. You will route the cable through the fitting and secure the fastening washer to clamp to the conduit ingress plate or plane:

1. Install all strain relief accessories into the open holes with locknut on the inside.
2. Loosen the external portion of the strain relief (that you intend to pass the cable through) to allow for cable passage.
3. Uncoil the pre-wired cable and pass it through the strain relief from the inside of the enclosure to the outside of the enclosure.
4. Tighten the external portion of the strain relief until the internal strain relief-fitting seals and holds the cable secure.
5. Hand-tighten until it is secure and the cable no longer moves when pulled. Do NOT overtighten.
6. Mount the controller ideally in an upright (vertical), sideways (horizontal), or flat position to/on a rigid surface with a minimum clear space of 3 inches on top and bottom. Note that there is no minimum clearance on the sides.

Important: For P06 controllers, the included fittings must be installed to maintain an IP65 rating. If you do not use the included cord grip kit, use fittings that meet a minimum of IP65 water ingress protection and install them according to that manufacturer's instructions.

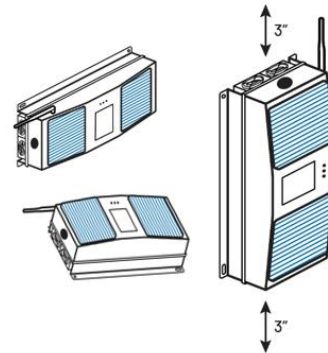

The antenna location indicates the top of the controller.

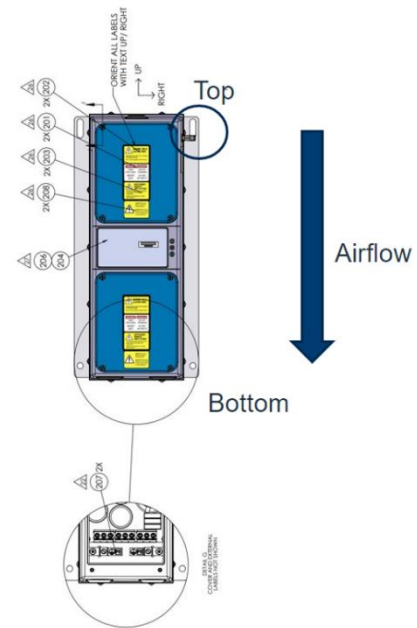

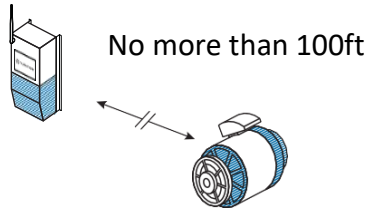

A note about Wi-Fi: If your business/organization requires that you manually disable Wi-Fi on the P06, please contact Turntide Technical Services for instructions.

Step	Instructions for Task 3: Install the Turntide Motor Controller	
3	If a longer motor power cable is needed, Turntide offers a 10m (~33ft) option. Contact support@turntide.com for lengths greater than 10m.	

Task 4: Wire Components

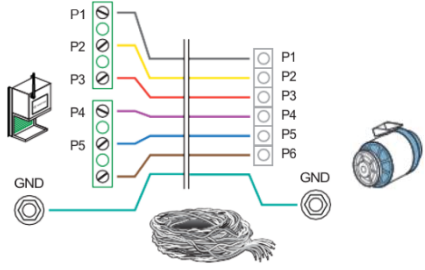
Step	Instructions for Task 4: Wire Components	
1	<p>Refer to Wiring Information for physical layout of the wires.</p> <p>If replacing a P04/P05 or SL120 with a <i>new</i> P06 or SL121 <u>OR</u> this is a first-time (or under warranty replacement) installation of a Turntide motor and P06 or SL121 controller:</p> <p>Wiring Information P06 and SL121</p> <ul style="list-style-type: none"> • Constant Volume AHU or Controlled by Thermostat on Control Board: SL121 Motor Controllers, Monitor Only • Constant Volume AHU or Controlled by Thermostat on Control Board: Wiring Information P06 Motor Controllers, Monitor Only • P06 & SL12: Multi Speed – Multi Start/Stop Signals • P06 & SL12: 0-10V / 2-10V plus Start/Stop Signal • P06 and SL121: 0-20mA / 4-20mA plus Start/Stop Signal 	<p>If replacing an under warranty P04/P05 or SL120 controller with another P04/P05 or SL120:</p> <p>Wiring Information P04/P05/SL120</p> <ul style="list-style-type: none"> • P04/P05/SL120 Single Speed – Single Start/Stop Signal • P04/P05/SL120 Multi Speed- Multi Start/Stop Signals • P04/P05/SL120 - 0-10V / 2-10V plus Start/Stop • P04/P05/SL120 - 0-20mA / 4-20mA plus Start/Stop Signal <p>Important:</p> <ol style="list-style-type: none"> 1. White and black pre-wired cables on P04/P05 and SL120 are used only with traditional thermostats. DO NOT use for speed control via 0-10V, 2-10V, 0-20mA, or 4-20mA signals. 2. If the existing motor uses an analog signal to control motor speed: Remove the white and black pre-wired cable assemblies from the P04/P05 and SL120 motor

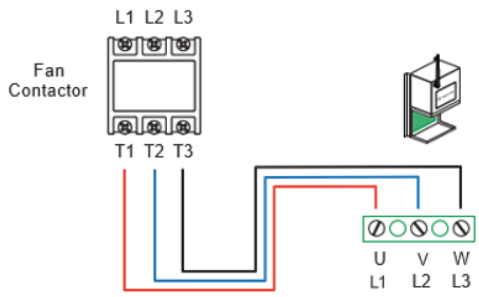
Step	Instructions for Task 4: Wire Components	
		<p>controller. These are intended for use with a traditional thermostat and will not be used when speed control is a 0-10V, 2-10V, 0-20 mA or 4-20 mA signal.</p> <p>3. If the AHU is constant volume or is controlled by a thermostat control board: Leave the control cables installed. Perform the motor controller installation procedures for an AHU installation based on instructions in <i>Motor System Installation Monitor Only Guide</i> in https://support.turntide.com/ and see Constant Volume AHU or Controlled by Thermostat on Control Board: SL121 Motor Controllers, Monitor Only in this guide.</p>
<p>2</p>	<ol style="list-style-type: none"> 1. Insert bushing into the motor electrical box. 2. Install the ferrules end of the motor power cable to the Turntide Motor Controller and unterminated leads to the Turntide Smart Motor. 3. Cut excess length from the raw end of the cable to required length, leaving ample slack for future servicing. 	

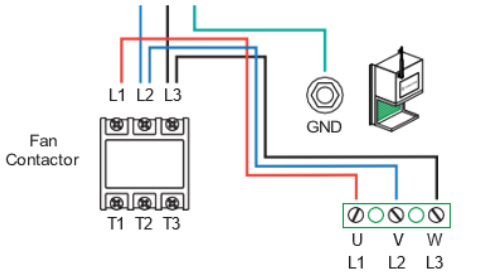

Step	Instructions for Task 4: Wire Components	
<p>3</p>	<p>Connect the induction motor power wires to the Turntide Motor Controller.</p> <p>If the original induction motor had separate overload wires, then they must be connected.</p>	 <p>SL120/SL121 motor controllers are labeled L1, L3, and L3</p> <p>P05/P06 motor controllers are labeled U, V, and W</p>
<p>4</p>	<p>Relocate induction motor power wires from the Load side of the fan contactor to the Line side, so that the Turntide Motor Controller has an unswitched power supply.</p> <div style="background-color: #f0f0f0; padding: 10px; border: 1px solid #ccc;">  <p>Warning: Ensure that input power ground is terminated on the controller. The ground wire from the motor to the controller does not provide sufficient grounding. If not properly grounded, the motor controller may not function correctly and could pose a safety hazard. Ensure you have a dedicated ground wire.</p> </div>	

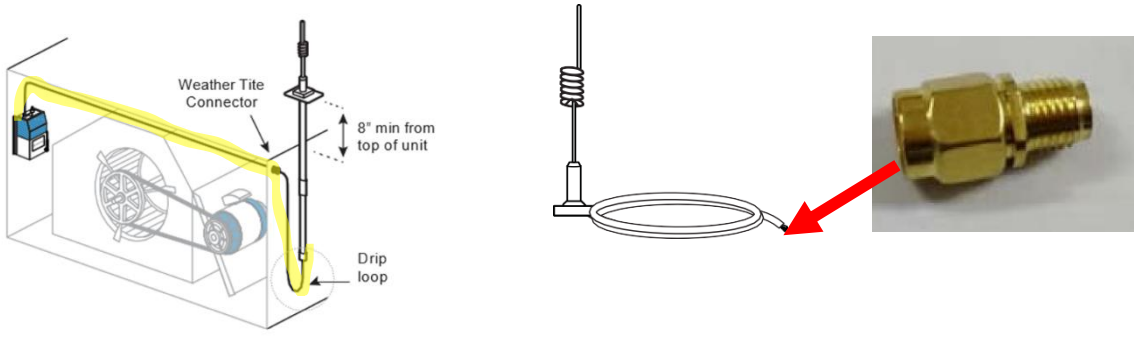
Step	Instructions for Task 4: Wire Components	
<p>5a</p>	<p>Air Sensor Installation</p> <p>If you are NOT using air sensors, skip this task (5a) and task (5c).</p> <p>Air sensors are NOT intended for installations exposed to weather.</p> <p>Install the supply air sensor downstream of the coil and heat exchanger, and the return air sensor in the return duct inlet. (Sensors are identical and can be installed in either location.) For more information, see Supply and Return Air Sensors.</p> <p>All cables provided by Turntide are NOT rated for outdoor use.</p>	
<p>5b</p>	<p>For horizontally ducted units, install the supply air sensor through blower deck just beyond the heat exchanger, and the return air sensor where duct enters unit.</p> <p>For units equipped with an economizer, install the return air sensor upstream of the economizer such that it senses the indoor return air, not the outside air, taking care not to impede damper blade operation.</p>	
<p>5c</p>	<p>Wire sensors to the Turntide Motor Controller per configuration specific wiring diagrams.</p> <p>Sensors are not polarity sensitive.</p>	

Step	Instructions for Task 4: Wire Components
6	<p>You are replacing an existing Turntide motor controller (for example, P04, P05, or SL120) with a newer motor controller (for example, P06 or SL121) AND you already have an RMK installed:</p> <p>You will use the existing External Dual-Band Wi-Fi antenna with 3m wire that is already wired through the AHU and attach it to the P06 or SL121 using the coaxial connector adapter that is provided.</p> 

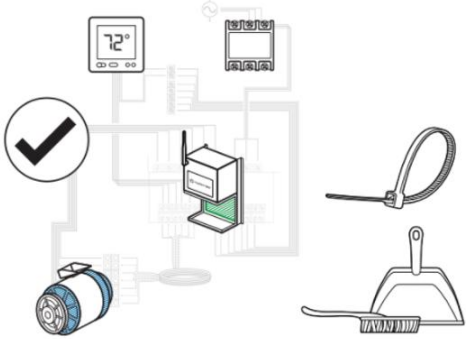
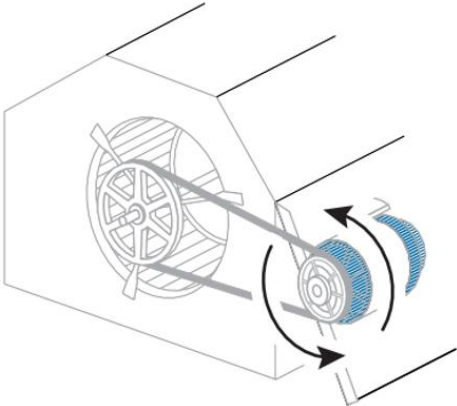
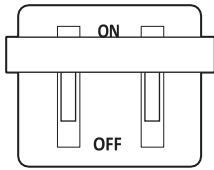
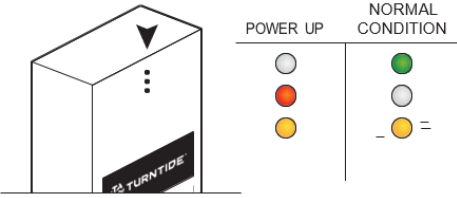
Task 5: Start Up the System

Step	Instructions for Task 5: Start Up the System	
1	<ol style="list-style-type: none"> 1. Verify that all wiring is correct and wire terminations are tight and secure. 2. Install cable ties around any loose wires and clean blower cavity of any debris from installation. 	
2	Turn the fan pulley by hand and verify that the motor pulley and fan rotate freely.	
3	Turn on power to the unit.	
4	Inspect the Turntide motor controller's LEDs for the correct run sequence. Upon power up: <ol style="list-style-type: none"> 1. The red and yellow LEDs will illuminate briefly. 2. The green LED will illuminate solidly. 	

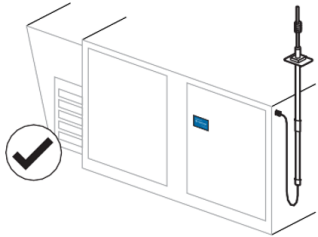
Step	Instructions for Task 5: Start Up the System	
<p>5</p>	<p>At this point, you must use the Turntide Technician App to commission the motor.</p> <p>A smart phone with the Turntide Technician mobile app is necessary for connecting to the motor controller. <i>You cannot complete the installation without using the app.</i></p> <p>Consult the Turntide Technician App User Guide at https://support.turntide.com/</p>	
<p>6</p>	<p>Affix the Turntide label on the exterior of the blower access panel and the Caution label on the blower housing.</p>	
<p>7</p>	<p>Confirm all access panels are re-installed and secure on unit. Ensure all unit disconnects are in the ON position and remove all materials and tools from roof/location.</p>	

Wiring Information P06 and SL121

Constant Volume AHU or Controlled by Thermostat on Control Board: SL121 Motor Controllers, Monitor Only

Wiring Information

SL 121 Motor Controllers

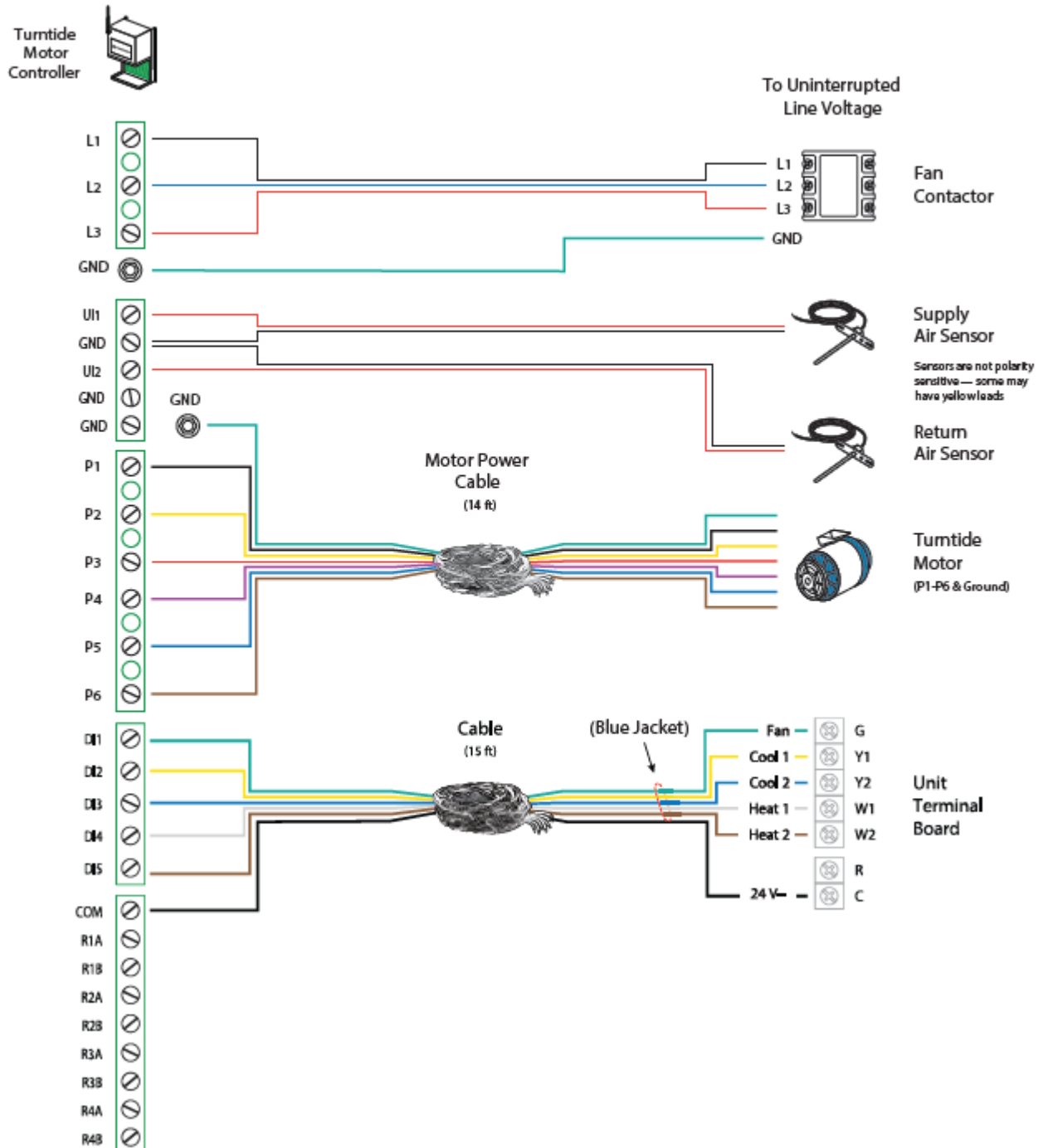

Constant Volume AHU or Controlled by Thermostat on Control Board: Wiring Information P06 Motor Controllers, Monitor Only

Wiring Information

P06 Motor Controllers

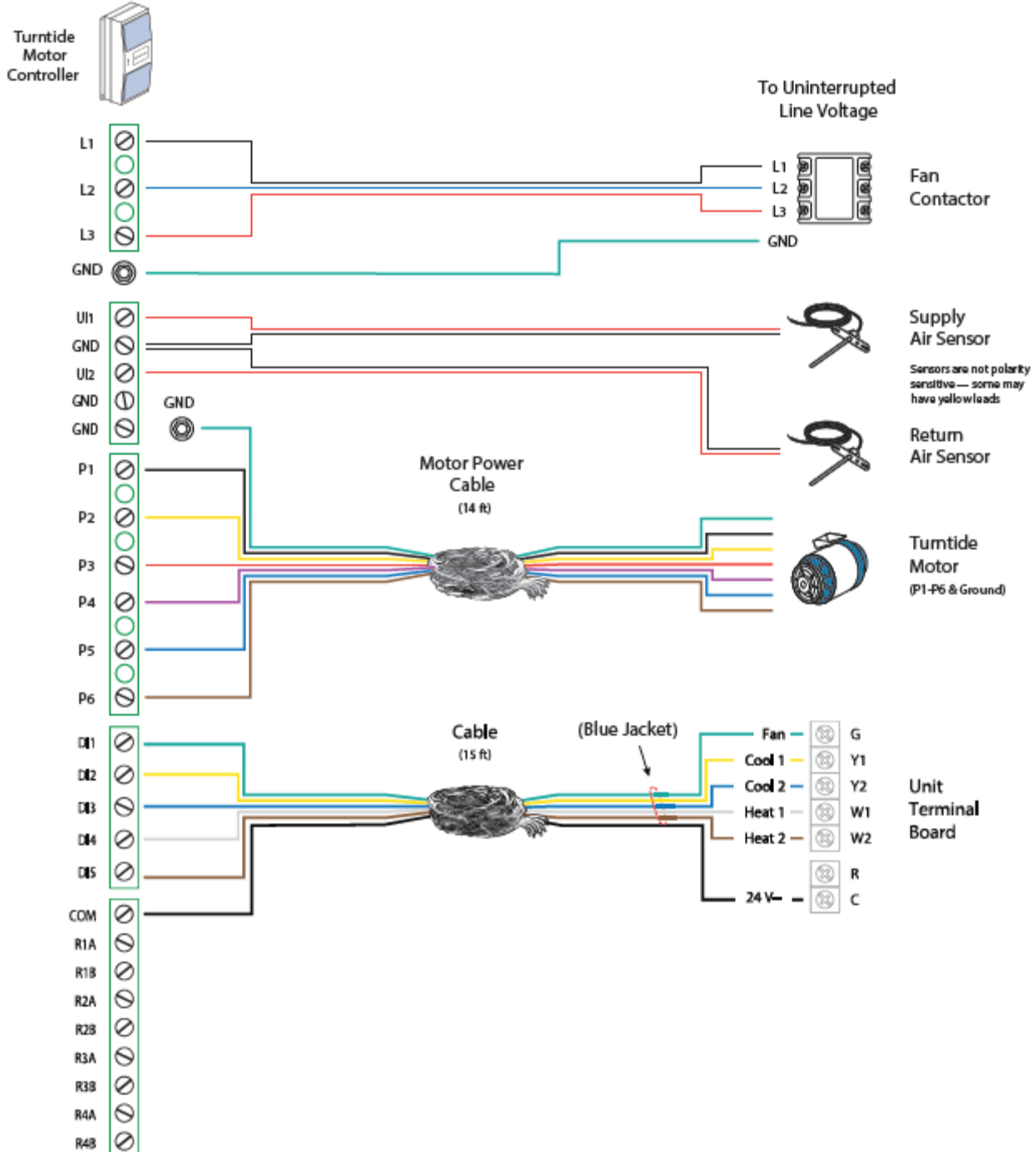

P06 & SL121: Single Speed – Single Start/Stop Signal

Use SL120 wiring for SL121 and P06

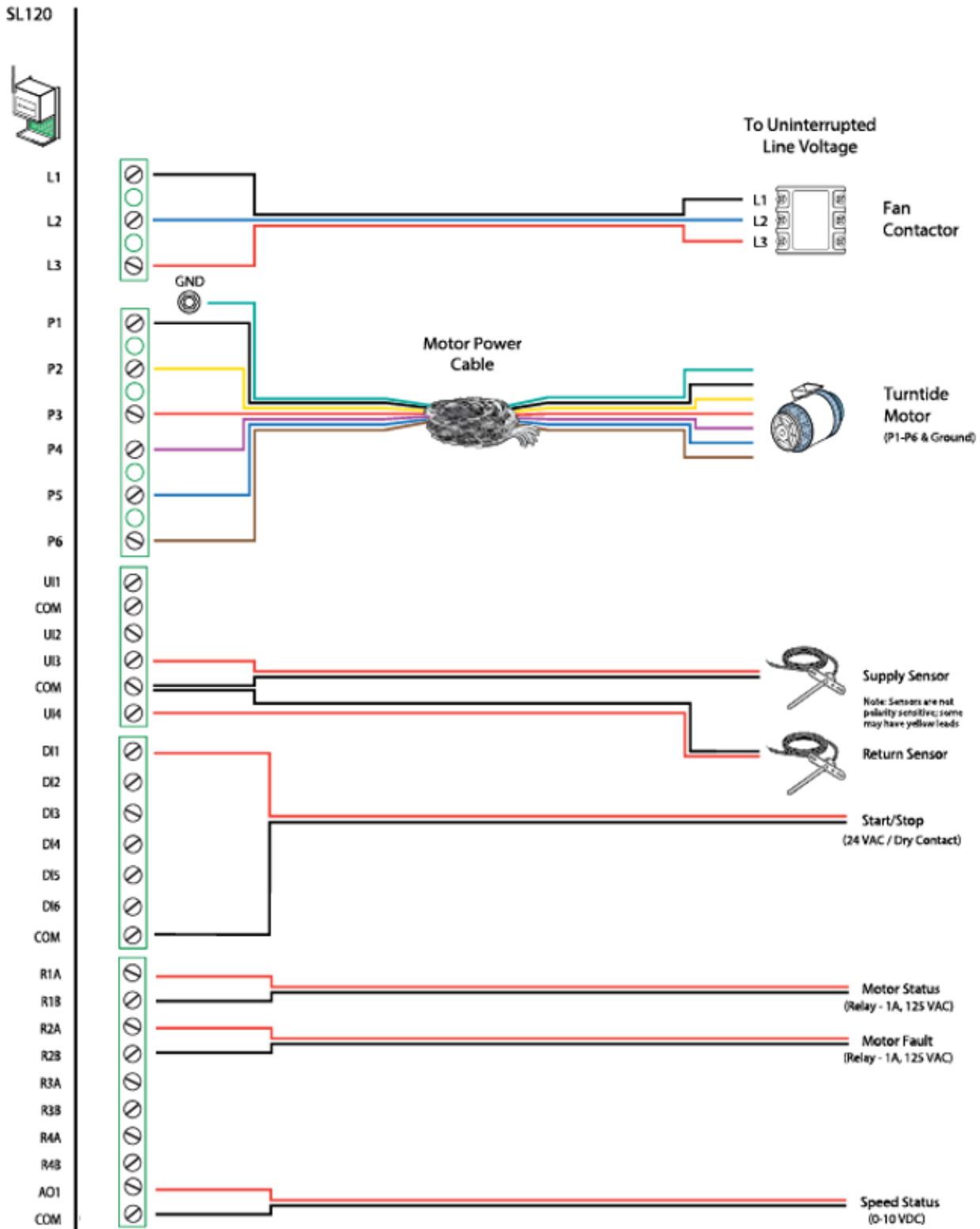

P06 & SL121: Multi Speed – Multi Start/Stop Signals

Use SL120 wiring for SL121 and P06

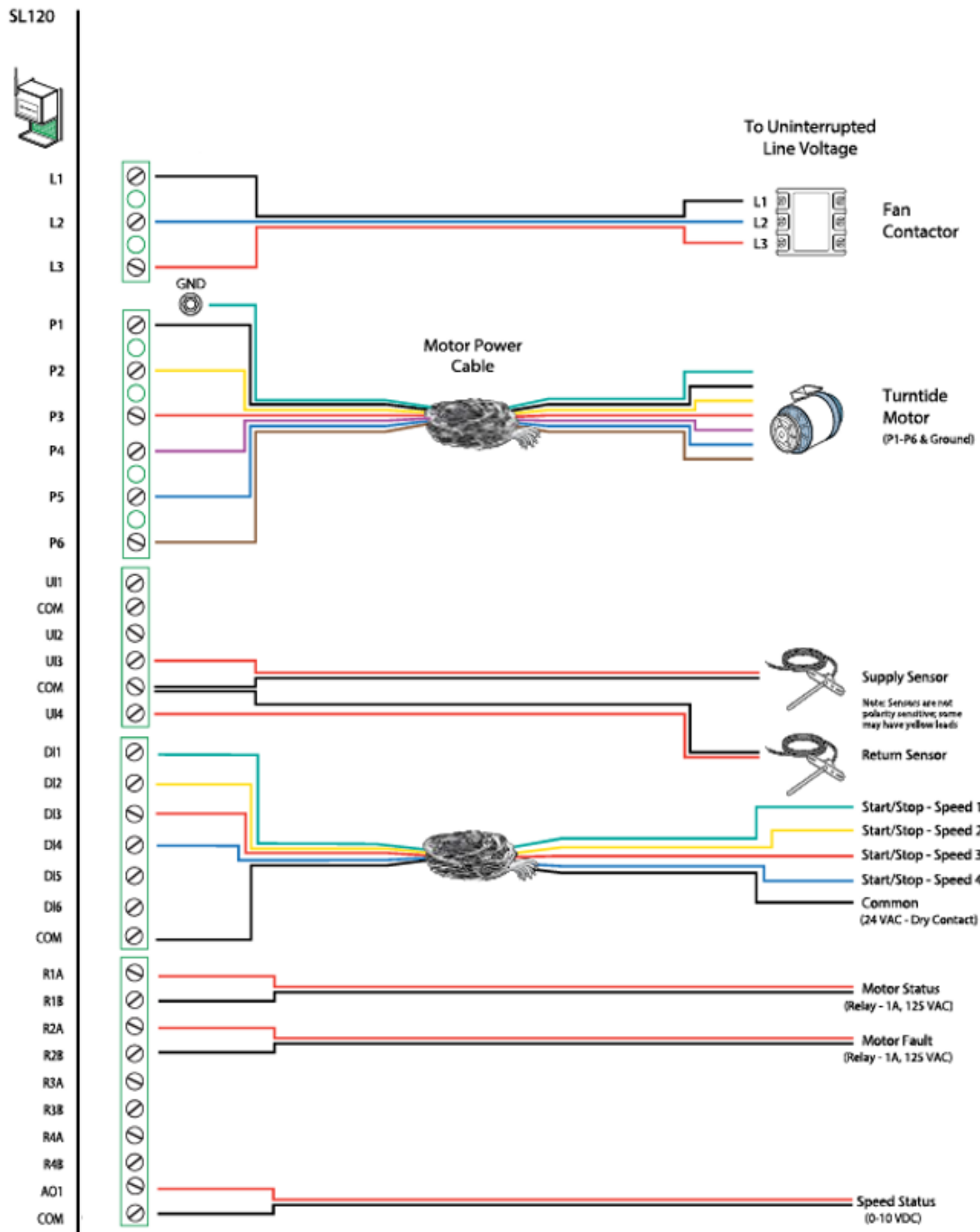

P06 & SL121: 0-10V / 2-10V plus Start/Stop Signal

Use SL120 wiring for SL121 and P06

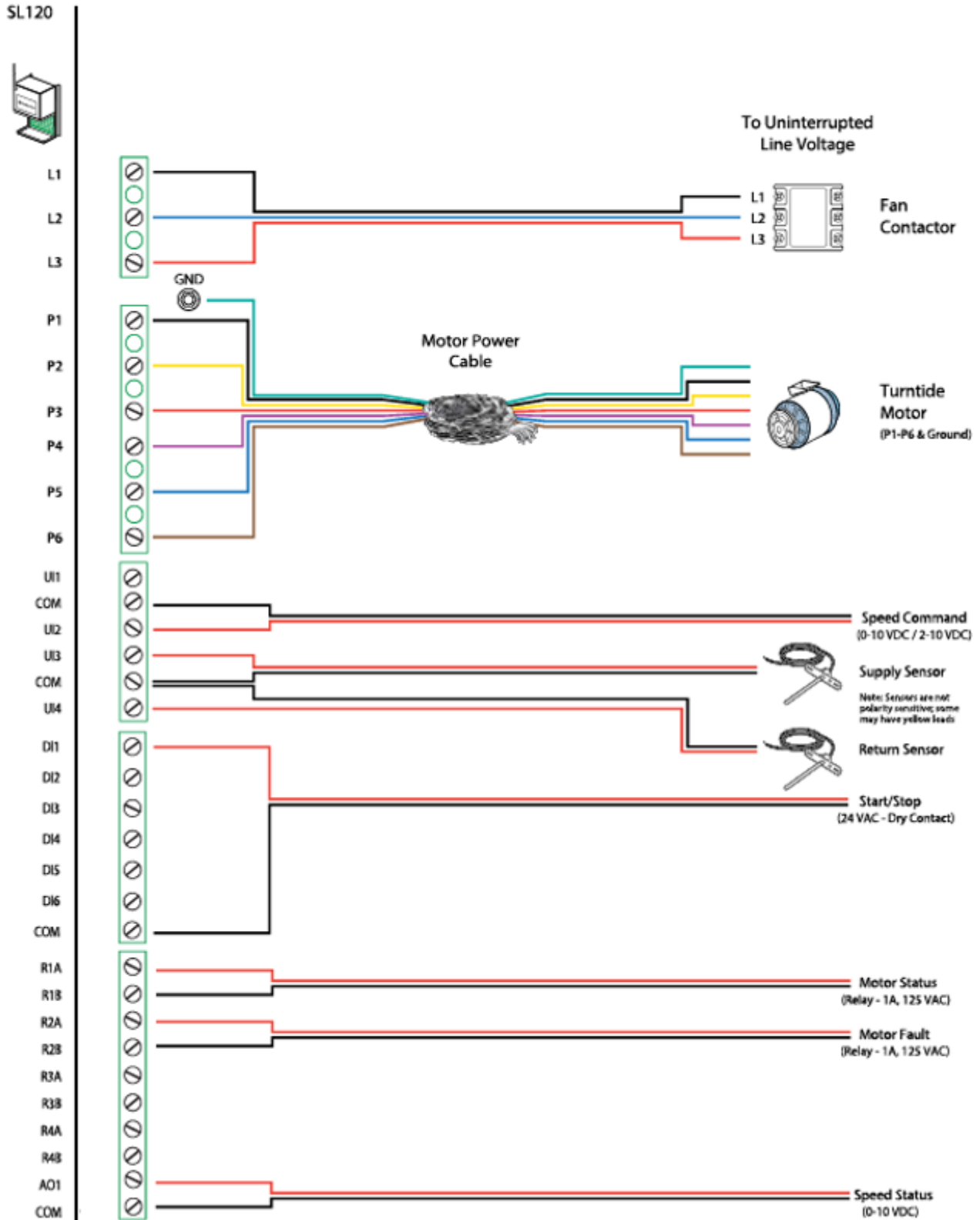

P06 and SL121: 0-20mA / 4-20mA plus Start/Stop Signal

Use SL120 wiring for SL121 and P06

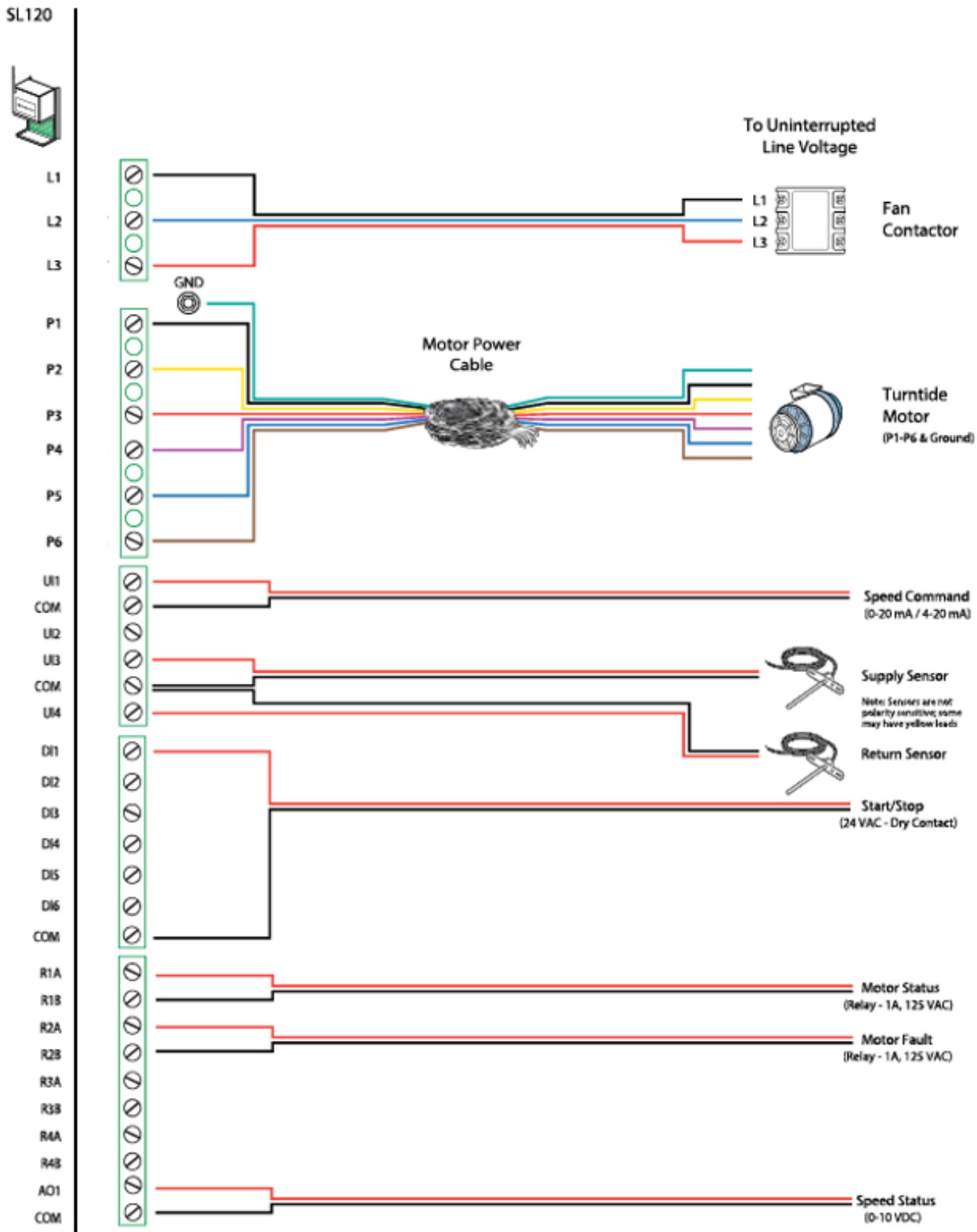

Wiring Information P04/P05/SL120

Note: White and black pre-wired cables on P04/P05 and SL120 are used only with traditional thermostats. **Do NOT** use for speed control via 0-10V, 2-10V, 0-20mA, or 4-20mA signals.

P04/P05/SL120 Single Speed – Single Start/Stop Signal

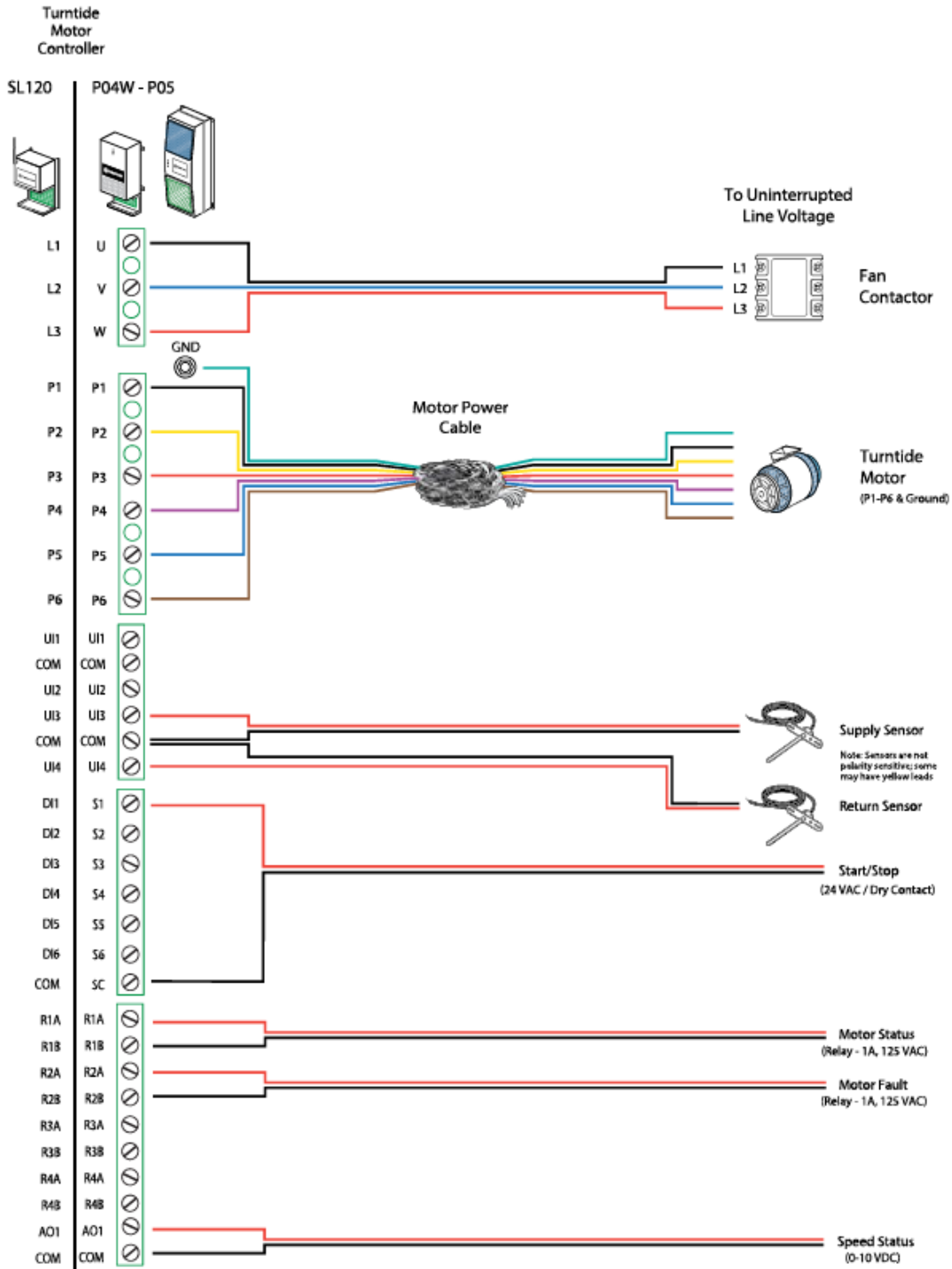

P04/P05/SL120 Multi Speed- Multi Start/Stop Signals

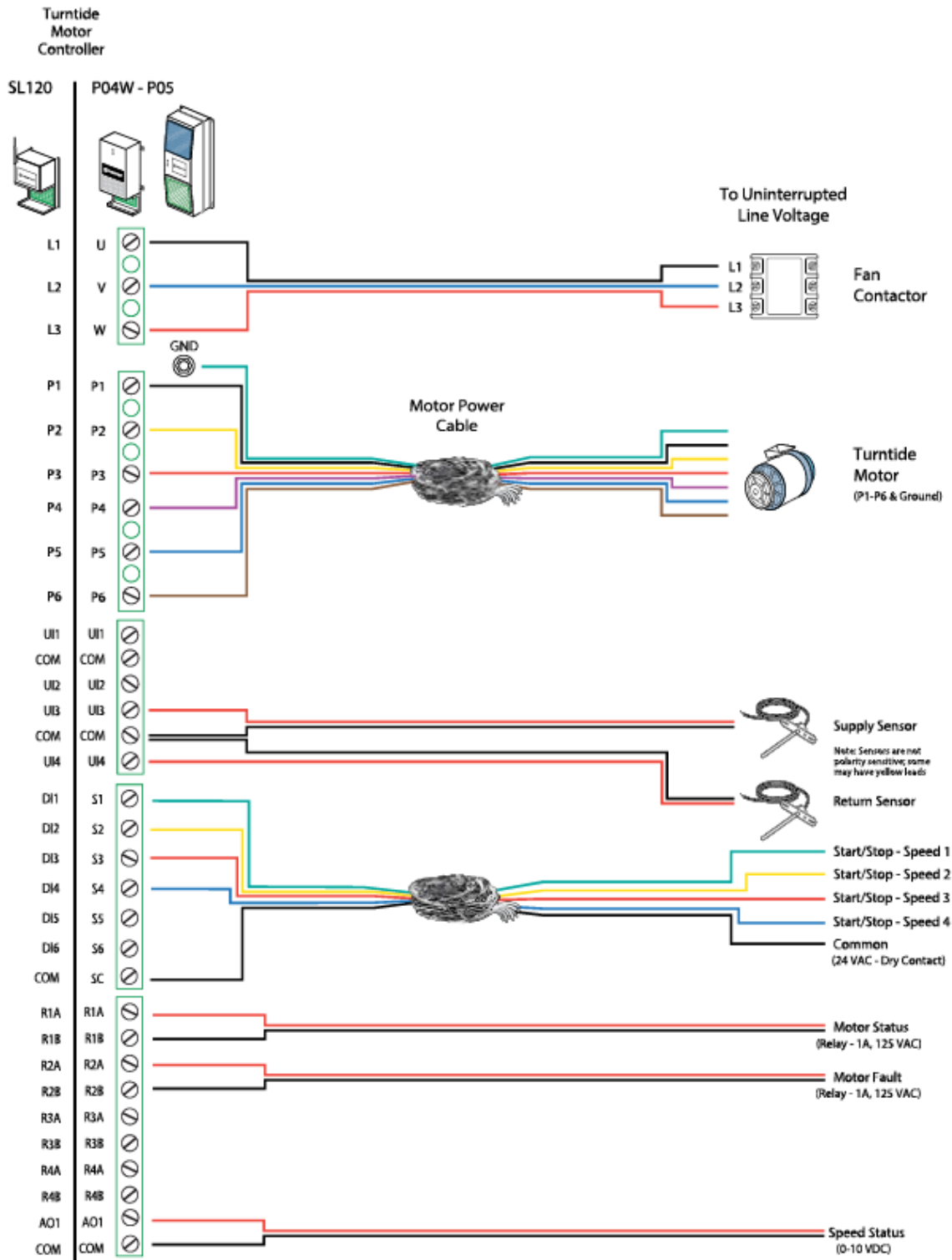

P04/P05/SL120 - 0-10V / 2-10V plus Start/Stop

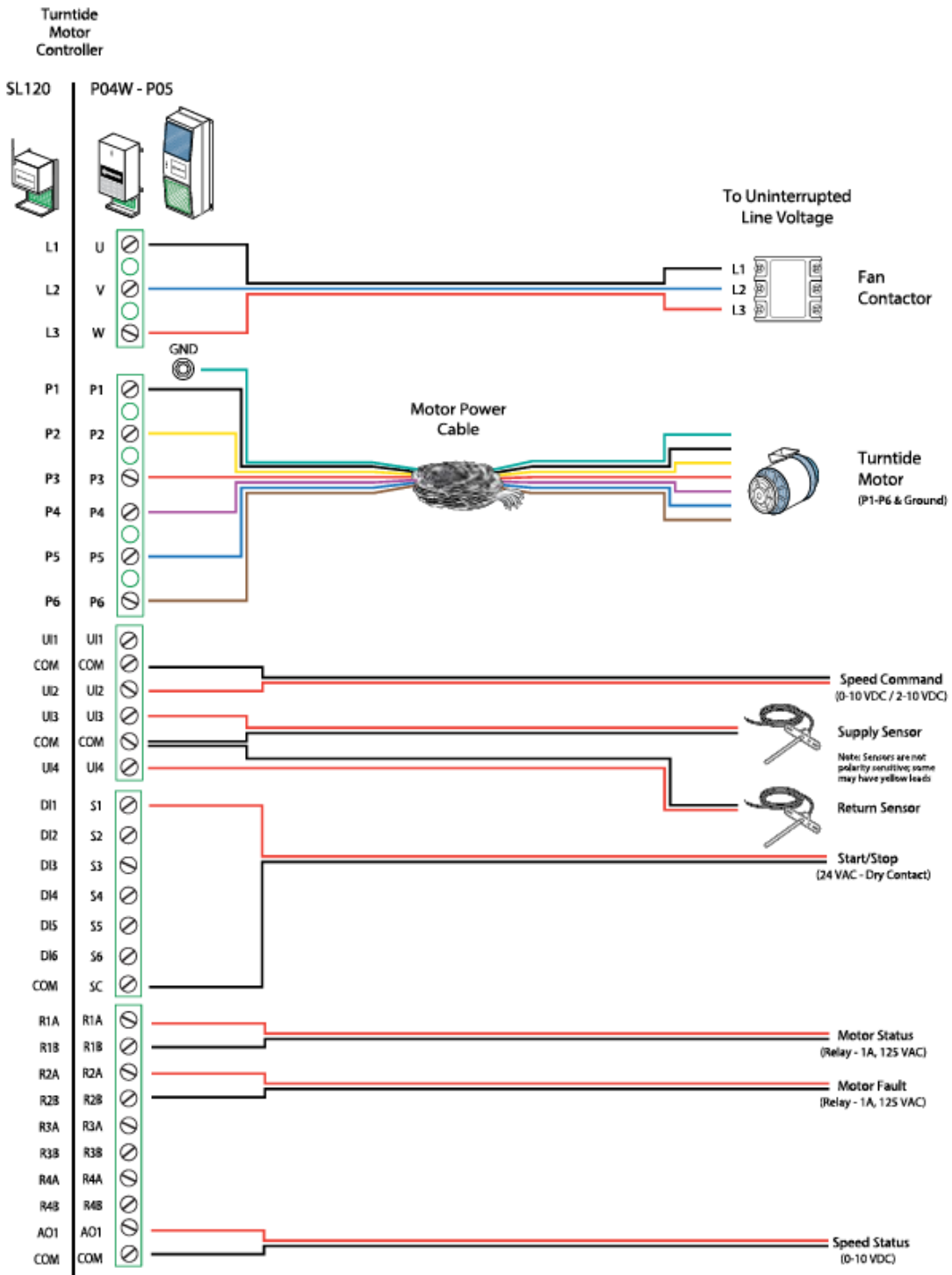

P04/P05/SL120 - 0-20mA / 4-20mA plus Start/Stop Signal

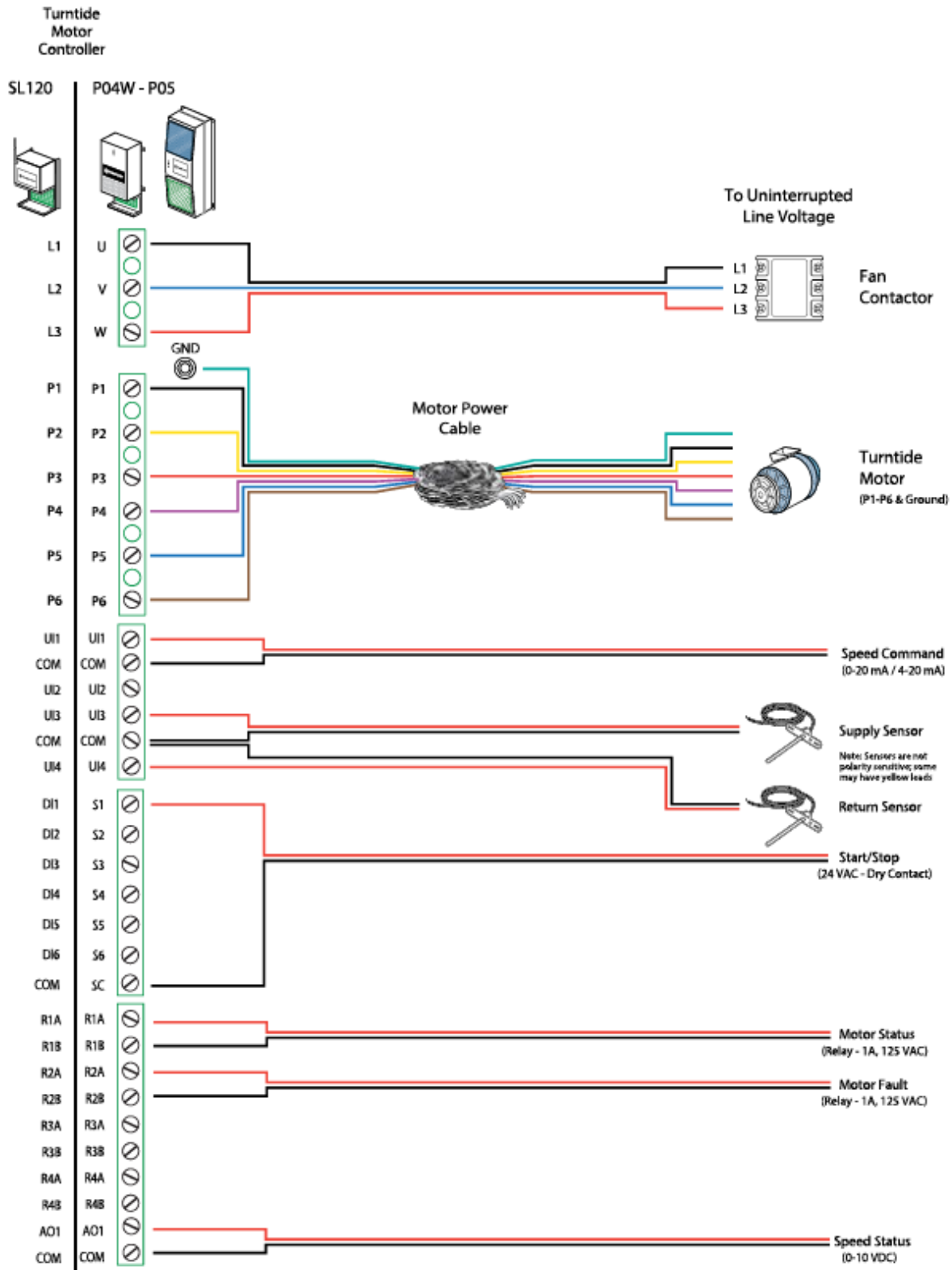

Appendix

How to Install Noise Isolation Feet

Table 5 Noise isolation kits matched with motors

KIT	SKU (motor and frame)	Notes
KIT-ISLN-FT-101	V01-0300-2-A00 V01-0300-4-A00 V01-0300-2-C00 V01-0300-4-C00 V01-0300-6-C00 V01-0300-2-D00 V01-0300-4-D00 V01-0300-6-D00 V02-0500-2-D00 V02-0500-4-D00 V02-0500-6-D00	Frames are A, C, D V02 motors with a 143/145T frame size require KIT_ISLN-FT-101.
KIT-ISLN-FT-201	V01-0300-2-F00 V01-0300-4-F00 V01-0300-6-F00 V02-0500-2-F00 V02-0500-4-F00 V02-0500-6-F00	Frame F V01-F motors, which are less than 3hp motors with a 182/184T frame size require KIT-ISLN-FT-201.
KIT-ISLN-FT-301	V03-1500-4-H00 V03-1500-6-H00	Frame H

Table 6 Torque required for Nylon-Patch Thread-Locking Fasteners

Kit	Fastener	Torque Inch Pounds	Torque Foot Pounds	Torque Nm
KIT-ISLN-FT-101	Two M6 x 1mm x 16mm Nylon-Patch Thread-Locking Fasteners	170.0 in-lbs ± 11.2 in-lbs	14 ft-lbs ± 1 ft-lbs	19.2 Nm ± 1.3 Nm
KIT-ISLN-FT-201	Four M6 x 1mm x 16mm Nylon-Patch Thread-Locking Fasteners	170.0 in-lbs ± 11.2 in-lbs	14 ft-lbs ± 1 ft-lbs	19.2 Nm ± 1.3 Nm
KIT-ISLN-FT-301	Eight M6 x 1mm x 16mm Nylon-Patch Thread-Locking Fasteners	170.0 in-lbs ± 11.2 in-lbs	14 ft-lbs ± 1 ft-lbs	19.2 Nm ± 1.3 Nm
	Eight M8 x 1.25mm x 16mm Nylon-Patch Thread-Locking Fasteners	330.0 in-lbs ± 19.5 in-lbs	27.5 ft-lbs ± 1.6 ft-lbs	37.3 Nm ± 2.2 Nm

Installation Steps

1. Identify the Turntide motor and frame size using the codes found on the nameplate of the motor and match it to a Noise Isolation Kit in [Table 4 Noise isolation kits matched with motors](#). Verify that your package contains the correct noise isolation feet for your motor and motor frame.

Figure 3 Example Motor V01 with Frame A

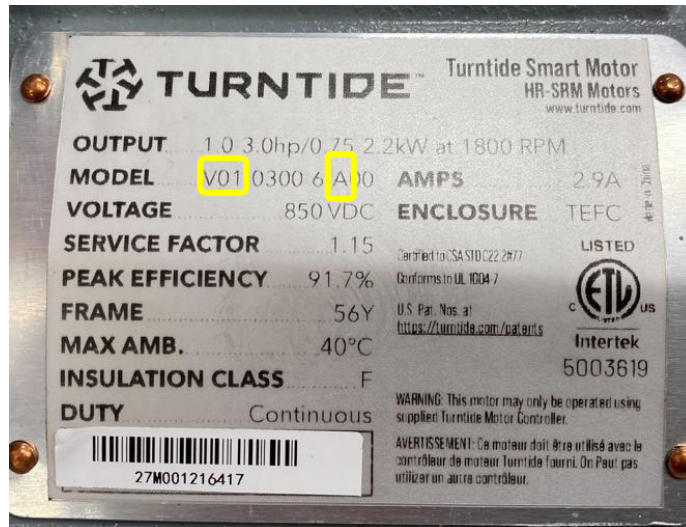

Go to instructions for your kit:

- [KIT-ISLN-FT-101 Motor Noise Isolation Feet Installation on V01 and V02 Motors, Frames A, C, and D](#)
- [KIT-ISLN-FT-201 Motor Noise Isolation Feet Installation on V01 and V02 Motors, Frame F](#)
- [KIT-ISLN-FT-301 Motor Noise Isolation Feet Installation on V03 Motors, Frame H](#)

Important: Do **NOT** use feet spacers or bolt sleeves with noise isolation feet.

KIT-ISLN-FT-101 Motor Noise Isolation Feet Installation on V01 and V02 Motors, Frames A, C, and D

Important: Assumes you have removed the existing mounting plate. Do **NOT** use feet spacers or bolt sleeves with noise isolation feet.

Instructions for KIT-ISLN-FT-101 Motor Noise Isolation Feet Installation on V01 and V02 Motors, Frames A, C, and D

1 Examine the new noise isolation feet:

- The feet in KIT-ISLN-FT-101 are **NOT** symmetrical. They are identified as *Left* and *Right*, when facing the shaft end of the motor.
- The shorter barrel faces toward the motor shaft end. (A sticker indicates the direction.)
- Color indicator lines on the isolation foot upper and lower sections indicate which pieces go together when reassembling the isolation foot.
- The left foot is marked **yellow** the right foot is marked **white**.

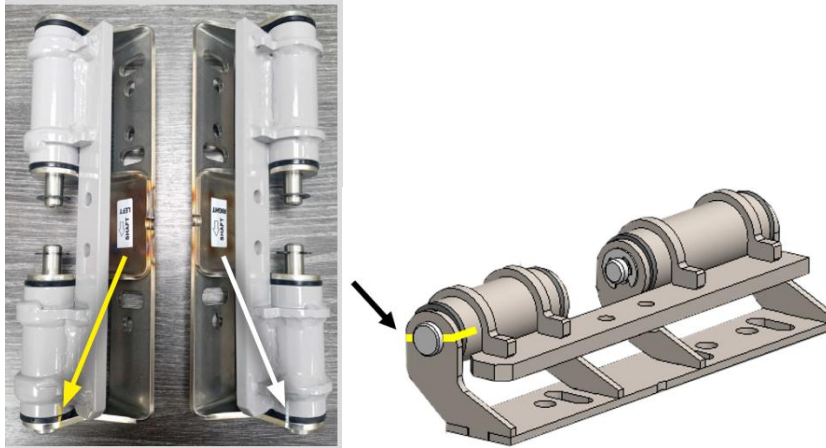

2 Disassemble the noise isolation feet to allow for easier installation:

Remove the E-clips from the clevis pins, sliding clevis pins out, so as to separate the lower foot section from the upper foot section.

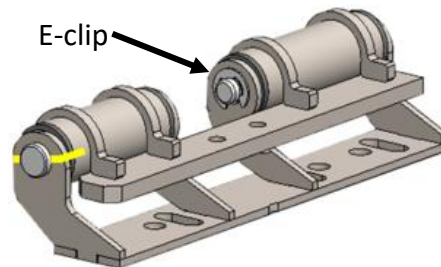

Instructions for KIT-ISLN-FT-101 Motor Noise Isolation Feet Installation on V01 and V02 Motors, Frames A, C, and D

- 3** Install the **lower section** of the Left and Right noise isolation feet **to the mounting plate** BUT do **not** tighten the bolts yet! The Left foot is marked with **yellow**, and the Right foot is marked with **white**.

The position of the motor (and therefore noise isolation feet) relative to the mounting plate is determined based on where the pulley/belt is on the blower fan as well.

Lower section of foot installed on the mounting plate.

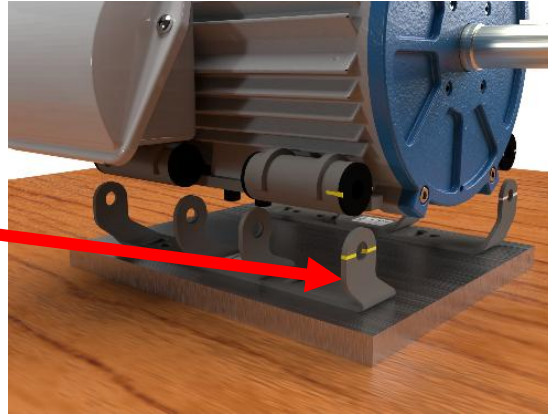

Special Cases:

Narrow Mounting Plate: If you are using a narrow mounting plate with a V01 motor and KIT-ISLN-FT-101, you will need filler blocks to allow the feet to hang over the edge of the mounting plate.

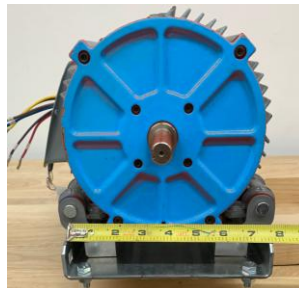
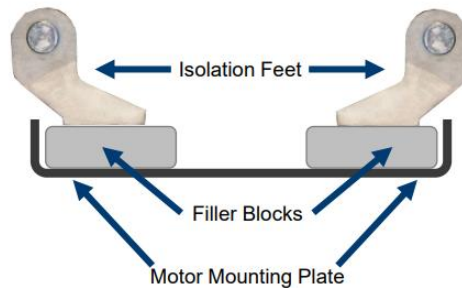

Vertical Mounting Plate: If your mounting plate is positioned vertically, at this point, follow instructions in [Special Instructions for Installation on a Vertical Mounting Plate](#) before proceeding with Step 5.

Instructions for KIT-ISLN-FT-101 Motor Noise Isolation Feet Installation on V01 and V02 Motors, Frames A, C, and D

- 4**
1. Install the upper section of the Left and Right noise isolation feet **to the motor**.
 2. Ensure that bolts connecting motor isolation feet to the motor body are torqued to specifications.

KIT-ISLN-FT-101 for motors V01 and V02 (A, C, and D frames) includes:

Two M6 x 1mm x 16mm Nylon-Patch Thread-Locking Fasteners

Torque: **14 ft-lbs ± 1 ft-lbs** (19.2 Nm ± 1.3 Nm)

Upper section of foot
installed on the motor.

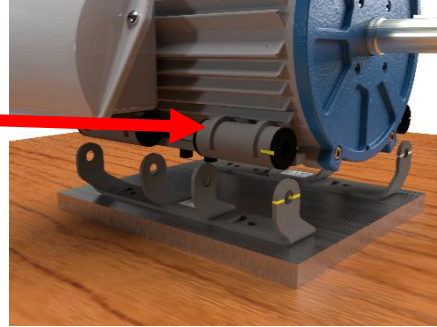

- 5**
1. Reconnect the upper and lower sections of the noise isolation feet using the clevis pins and E-clips.
 2. Carefully align the motor on the mounting plate on a flat surface.
 3. Fully tighten the lower noise isolation feet bolts.



- 6** Reinstall the motor and mounting plate assembly in the AHU.

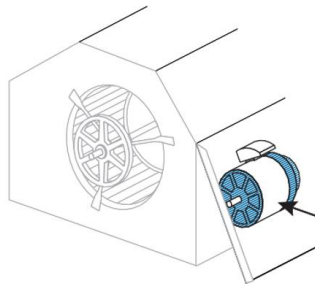

Go back to **Task 1: Uninstall the existing motor and Install the Turntide Motor, Step 7.**

KIT-ISLN-FT-201 Motor Noise Isolation Feet Installation on V01 and V02 Motors, Frame F

Important: Assumes you have removed the existing mounting plate. Do **not** use feet spacers or bolt sleeves with noise isolation feet.

Instructions for KIT-ISLN-FT-201 Motor Noise Isolation Feet Installation on V01 and V02 Motors, Frame F

1 Examine the new noise isolation feet:

1. The feet in KIT-ISLN-FT-201 are **NOT symmetrical**. They are identified as Left and Right, when facing the shaft end of the motor.
2. Color indicator lines on the isolation foot upper and lower sections indicate which pieces go together when reassembling the isolation foot. The left foot is marked **yellow** the right foot is marked **white**.

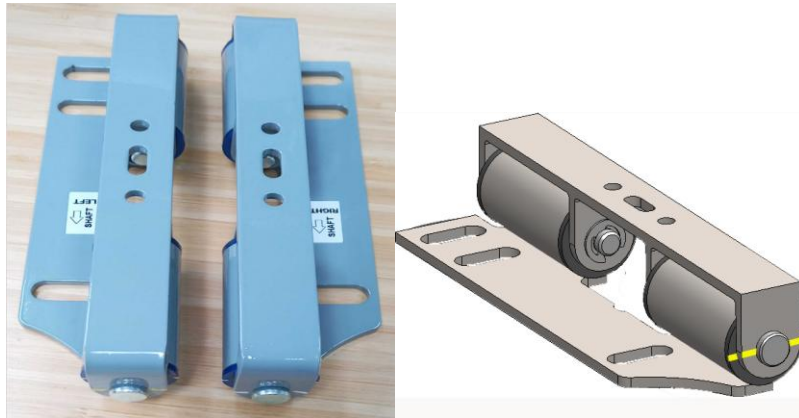

2 Disassemble the noise isolation feet:

Remove the E-clips from the clevis pins, sliding clevis pins out, so as to separate the lower foot section from the upper foot section.

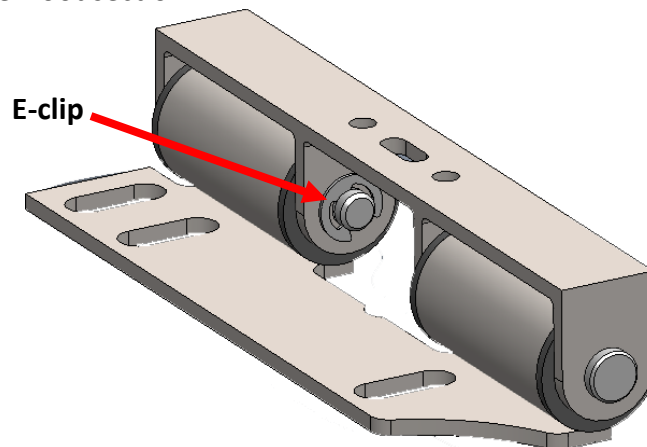

Instructions for KIT-ISLN-FT-201 Motor Noise Isolation Feet Installation on V01 and V02 Motors, Frame F

- 3** Install the **lower section** of the Left and Right noise isolation feet **to the mounting plate** BUT do **NOT** tighten the bolts yet! The Left foot is marked **yellow** the Right foot is marked **white**. *The position of the motor (and therefore noise isolation feet) relative to the mounting plate is determined based on where the pulley/belt is on the blower fan as well.*

Lower section of foot installed on the mounting plate

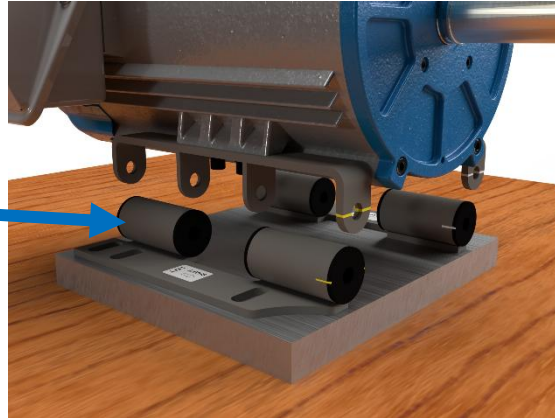

- 4**
1. Install **the upper section** of the Left and Right noise isolation feet **to the motor**.
 2. Ensure that bolts connecting motor isolation feet to the motor body are torqued to specifications.
- KIT-ISLN-FT-201** Motor Noise Isolation Feet Installation on V01 and V02 Motors, Frame F includes:
 Four M6 x 1mm x 16mm Nylon-Patch Thread-Locking Fastener
 Torque: **14 ft-lbs ± 1 ft-lbs (19.2 Nm ± 1.3 N)**

Upper section of foot installed on the motor.

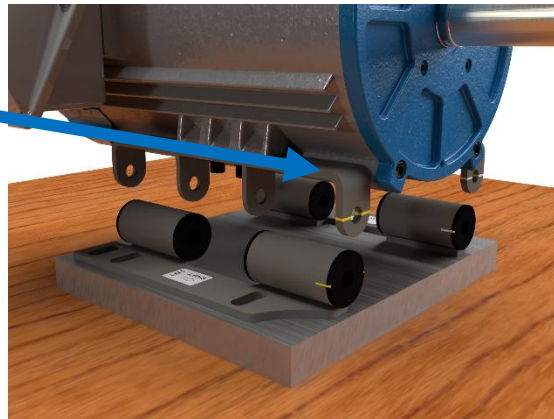

Instructions for KIT-ISLN-FT-201 Motor Noise Isolation Feet Installation on V01 and V02 Motors, Frame F

- 5**
1. Reconnect the upper and lower sections of the noise isolation feet using the clevis pins and E-clips.
 2. Carefully align the motor on the mounting plate on a flat surface.
 3. Fully tighten the lower noise isolation feet bolts to the mounting plate.



- 6** Reinstall the motor and mounting plate assembly in the AHU.

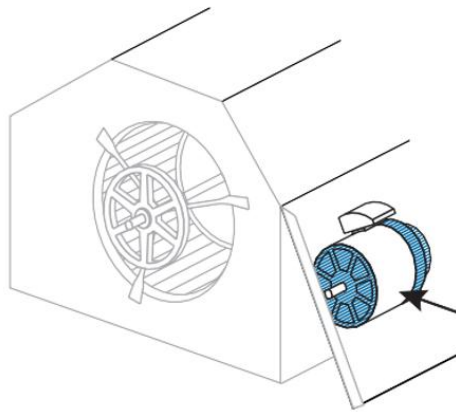

Go back to **Task 1: Uninstall the existing motor and Install the Turntide Motor, Step 7.**

KIT-ISLN-FT-301 Motor Noise Isolation Feet Installation on V03 Motors, Frame H

Important: Assumes you have removed the existing mounting plate. Do **not** use feet spacers or bolt sleeves with noise isolation feet.

Instructions for KIT-ISLN-FT-301 Motor Noise Isolation Feet Installation on V03 Motors, Frame H

- 1 Examine the new noise isolation feet:**
The feet in KIT-ISLN-FT-301 are **symmetrical**.

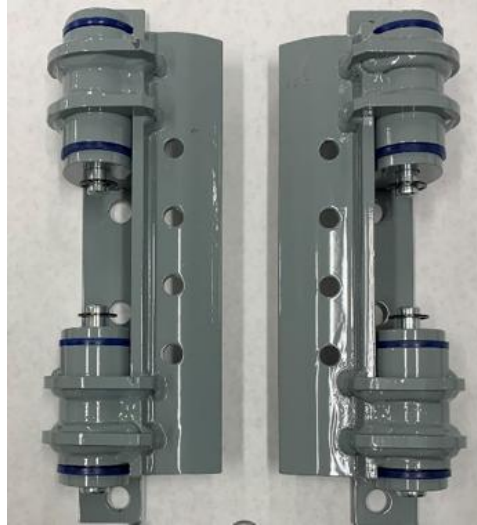

- 2 Disassemble the noise isolation feet:**
Remove the E-clips from the clevis pins, sliding clevis pins out, so as to separate the lower foot section from the upper foot section.

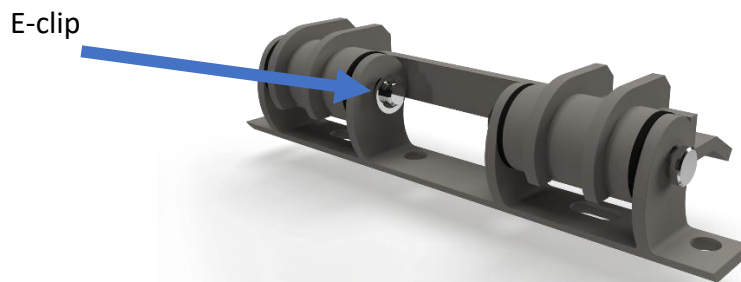

Instructions for KIT-ISLN-FT-301 Motor Noise Isolation Feet Installation on V03 Motors, Frame H

- 3** Install the **lower section** of the Left and Right noise isolation feet **to the mounting plate** BUT do **NOT** tighten the bolts yet!

The position of the motor (and therefore noise isolation feet) relative to the mounting plate is determined based on where the pulley/belt is on the blower fan as well.

Lower section of foot installed on the mounting plate

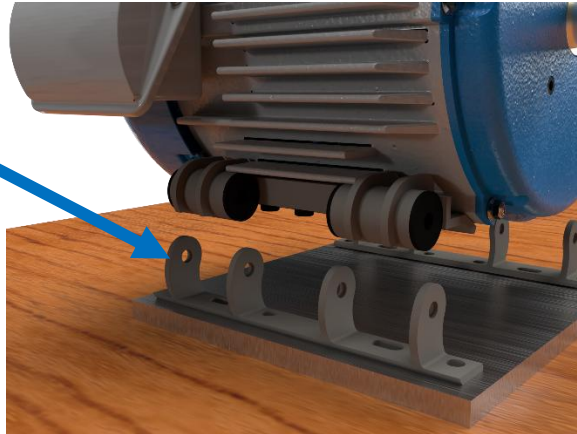

- 4**
1. Install the upper section of the noise isolation feet **to the motor**.
 2. Ensure that bolts connecting motor isolation feet to the motor body are torqued to specifications. Depending on the housing of your V03 motor, you will use the M6 or M8 fasteners.

KIT-ISLN-FT-301 Motor Noise Isolation Feet Installation on V03 Motors, Frame H includes:

Eight M6 x 1mm x 16mm Nylon-Patch Thread-Locking Fasteners
Torque: **14 ft-lbs ± 1 ft-lbs** (19.2 Nm ± 1.3)

Eight M8 x 1.25mm x 16mm Nylon-Patch Thread-Locking Fasteners
Torque: **27.5 ft-lbs ± 1.6 ft-lbs** (37.3 Nm ± 2.2 Nm)

Upper section of foot installed on the motor.

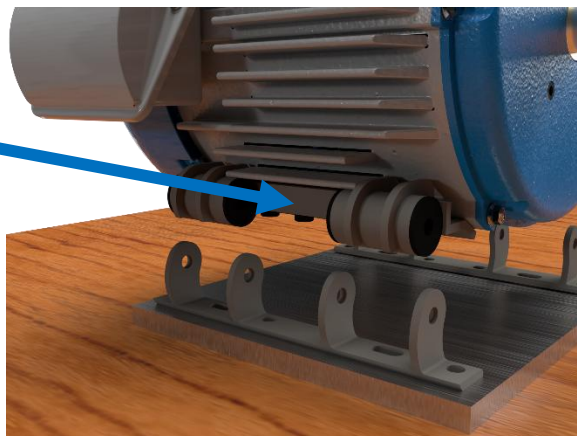

Instructions for KIT-ISLN-FT-301 Motor Noise Isolation Feet Installation on V03 Motors, Frame H

- 5**
1. Reconnect the upper and lower sections of the noise isolation feet using the clevis pins and E-clips.
 2. Carefully align the motor on the mounting plate on a flat surface.
 3. Fully tighten the lower noise isolation feet bolts.

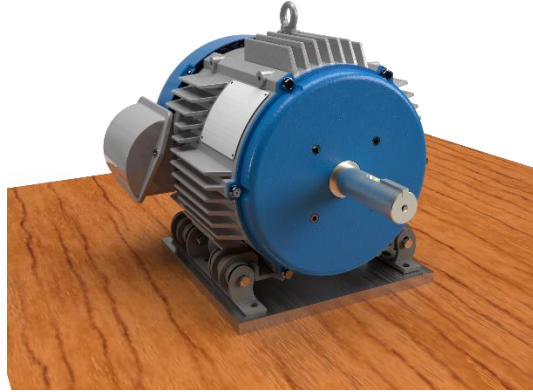

- 6** Reinstall the motor and mounting plate assembly in the AHU.

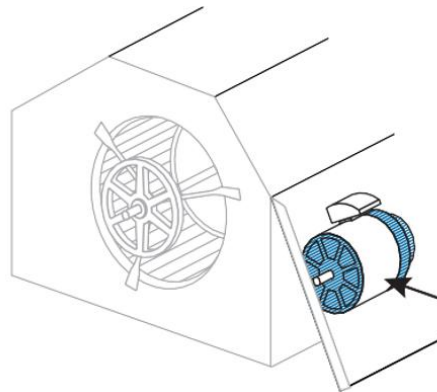

Go back to **Task 1: Uninstall the existing motor and Install the Turntide Motor, Step 7.**

Special Instructions for Installation on a Vertical Mounting Plate

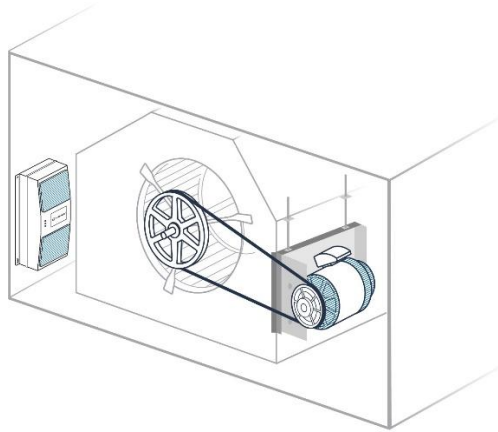

Key Concepts

BEFORE:

In an existing vertical mounting plate installation, the bolts are positioned with the thread facing the motor. As you can see in the example image, the bolt extends towards the motor.

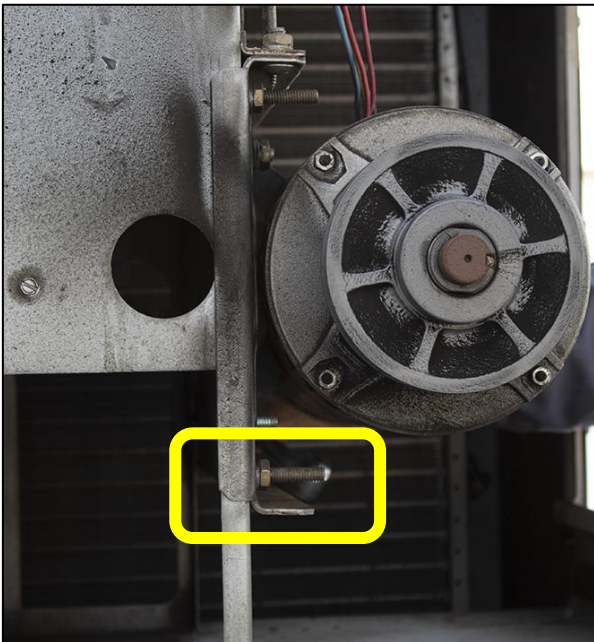

AFTER:

You will be reversing the mounting bolts (180 degrees) with the noise isolation feet installation. As you can see in the example image, the bolt thread now extends **towards** the AHU. This allows you to access the nut when belt tension adjustment is necessary.

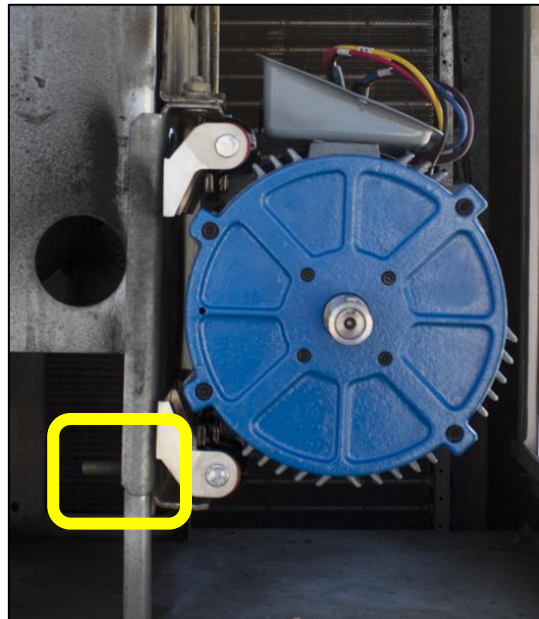

In your *existing* Turntide motor installation, the carriage bolts may have sleeves.

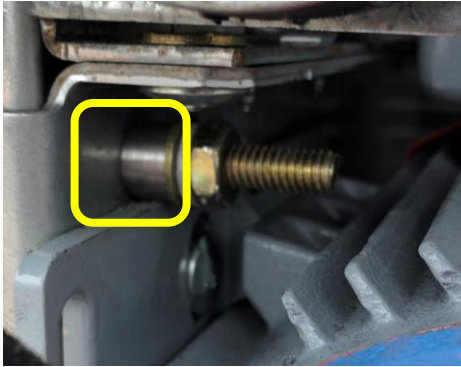

You will **not** use sleeves with the installation of the noise isolation feet.

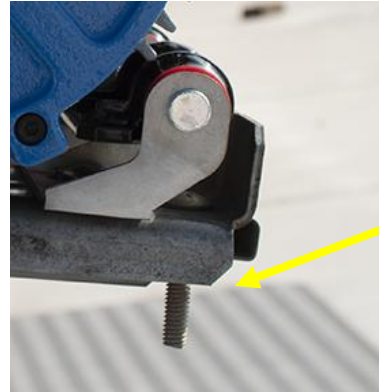

No sleeve used

Before you begin, note the following:

1. Assumes you have removed the existing mounting plate.
2. **Important:** Feet spacers, bolt sleeves, and filler blocks are **not** applicable to this configuration.
3. You will reuse all the existing mounting bolts but turn all the bolts 180 degrees.
4. In the upper left corner of the mounting plate, use a **5/16in x 1in** carriage bolt. Using a shorter bolt ensures that it will **NOT** protrude into the blower housing.
5. You might have to shift the entire assembly down to get a good fit. This is necessary if the blower housing is preventing ample space for nut installation on the bolt in the upper right corner and proper bolt seating.

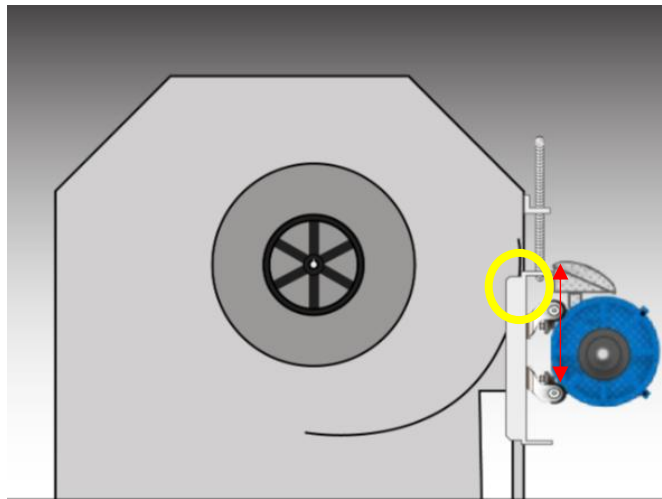

- 1**
1. Install the **5/16in x 1in** carriage bolt in the upper left corner of the **top** of mounting plate.
 2. Install the remaining bolts and add push nut bolt retainer to the bolts nearest the shaft/belt.

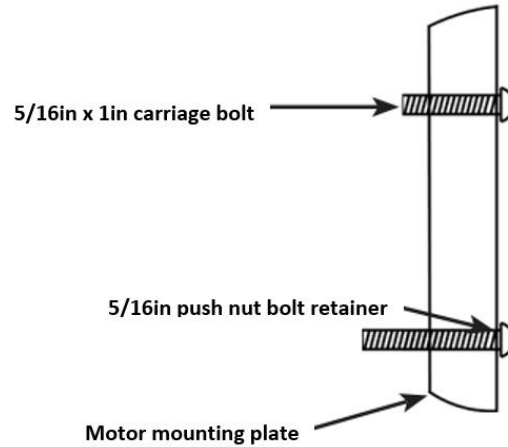
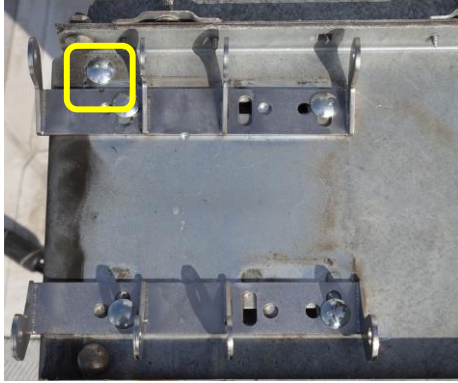

- 2**
- Install the **lower section** of the Left and Right noise isolation feet **to the mounting plate** BUT do **not** tighten the bolts yet! The Left foot is marked **yellow**, and the Right foot is marked **white**. *The position of the motor (and therefore noise isolation feet) relative to the mounting plate is determined based on where the pulley/belt is on the blower fan as well.*

Lower section of foot installed on the mounting plate.

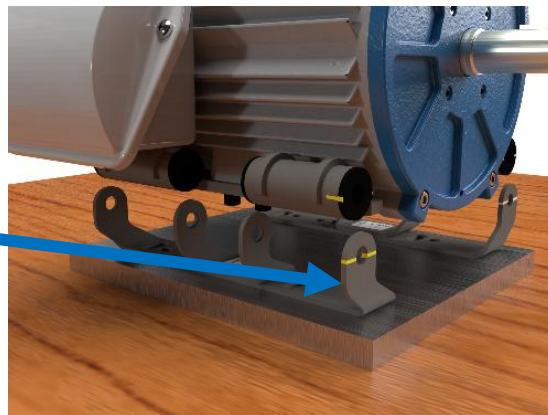

- 3**
1. Install the upper section of the Left and Right noise isolation feet **to the motor**.
 2. Ensure that bolts connecting motor isolation feet to the motor body are torqued to specifications.

KIT-ISLN-FT-101 for motors V01 and V02 (A, C, and D frames) includes:
Two M6 x 1mm x 16mm Nylon-Patch Thread-Locking Fasteners
Torque: **14 ft-lbs ± 1 ft-lbs** (19.2 Nm ± 1.3 Nm)

Upper section of foot installed on the motor.

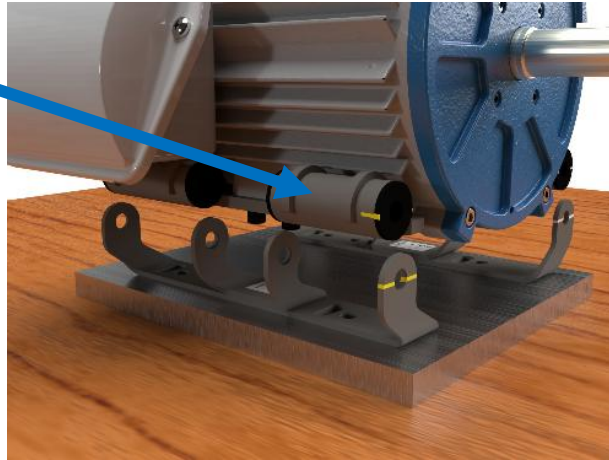

- 4**
1. Reconnect the upper and lower sections of the noise isolation feet using the clevis pins and E-clips.
 2. Carefully align the motor on the mounting plate on a flat surface.
 3. Fully tighten the lower noise isolation feet bolts.



5 Reinstall the motor and mounting plate assembly in the AHU.

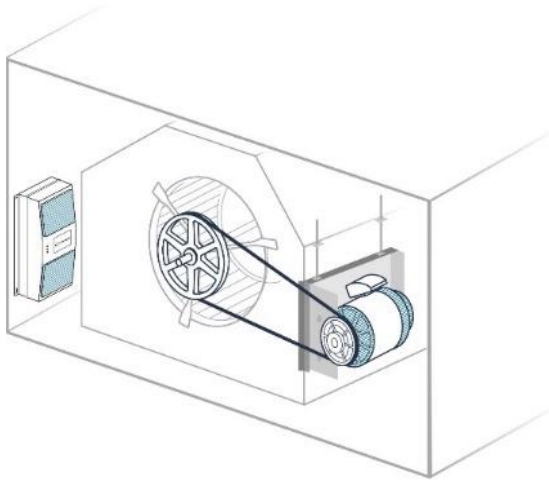

Go back to [Task 1: Uninstall the existing motor and Install the Turntide Motor, Step 7.](#)

Special Case: Replacing Old Turntide Motor Controller with a P06 or SL121 Motor Controller

How to Replace a P04/P05/SL120 with SL121/P06 Control Wiring

Note: The P04, P05, and SL120 motor controllers are prewired with a **white** input and a **black** output cable, each with a 300 V rating.

- The **white** input wired in parallel with the thermostat 24V signals to the AHU.
 - The **black** cable wired for 24V Common.
1. When removing the existing controller, retain the existing **BLACK** and **WHITE** wire harnesses.
 2. Remove and retain the orange jumper wires that are connected to terminals **R1B, R2B, R3B, and R4B**.
 3. Remove the blue wire harness from the new Turntide motor controller. *It is not used in this application.*
 4. Install the orange jumper wires in the new motor controller terminals **R1B, R2B, R3B, and R4B**.
 5. Connect the wires of the **BLACK** harness as follows:
 - a. Red to R1B (this is already connected to the orange jumper)
 - b. Black to COM
 - c. Yellow to R1A
 - d. Blue to R2A
 - e. White to R3A
 - f. Brown to R4A
 - g. Green to DI1 (this already connected to the green wire of the **WHITE** harness)
 6. Connect the wires of the **WHITE** harness as follows:
 - a. Green to DI1 (this is already connected to the green wire of the **BLACK** harness)
 - b. Yellow to DI2
 - c. Blue to DI3
 - d. White to DI4
 - e. Brown to DI5

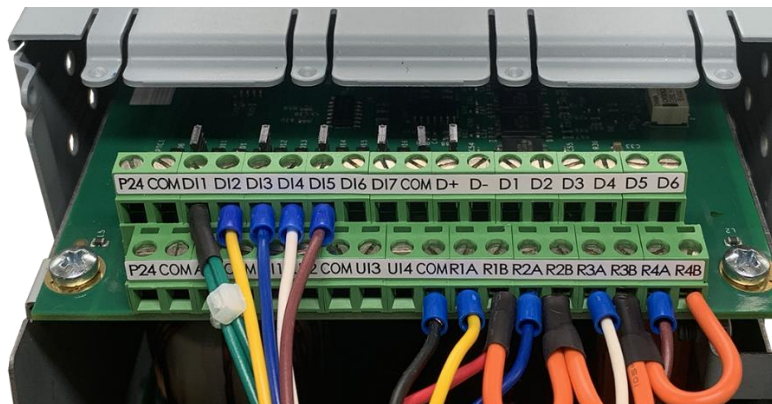

Figure 4 Older SL120 Motor Controller Showing Existing Control Wiring

Best Practices for Installing Belt



Caution: To properly follow these instructions, you will need a belt tensioning tool that utilizes a spring depressor that reads in pounds and fractions of an inch.
Do not attempt to tension the belt without the proper testing tools.
Failure to properly tension the belt may cause bearing failure or permanent damage to the motor.

Belts will loosen after running and warming up. Final adjustments should be made after 10 minutes of run time. If the existing belt shows signs of excessive wear, it should be replaced.

1. Measure the distance (inches) from the center shaft of the motor to the center shaft of the blower wheel.

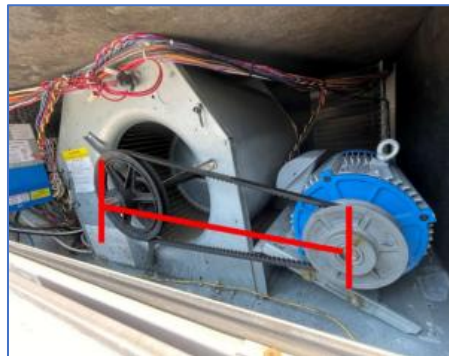

2. Round the distance to the closest value. If evenly divided, round down. *For example, 20 1/2 inches is rounded down to 20 inches.*
3. Set the bottom O-ring of the belt tension gauge to that value. *For example, slide the O-ring down to the 20-inch mark or notch on your gauge.*

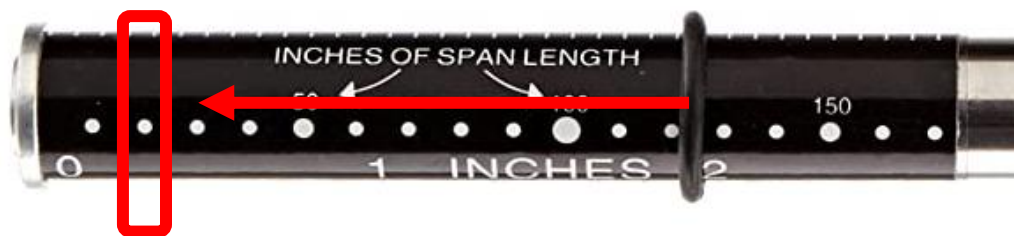

4. Set the top O-ring at zero (0). (Slide the O-ring to the base.)



- Set a straight edge across the top of the belt. Deflect the belt until the bottom **O-ring** is in the same plane as the straight edge.

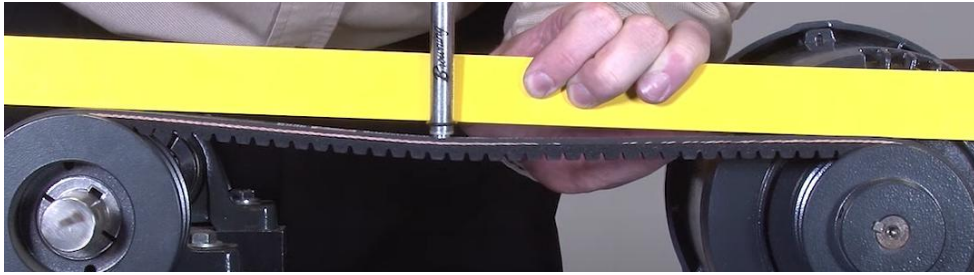

HVAC industry standard

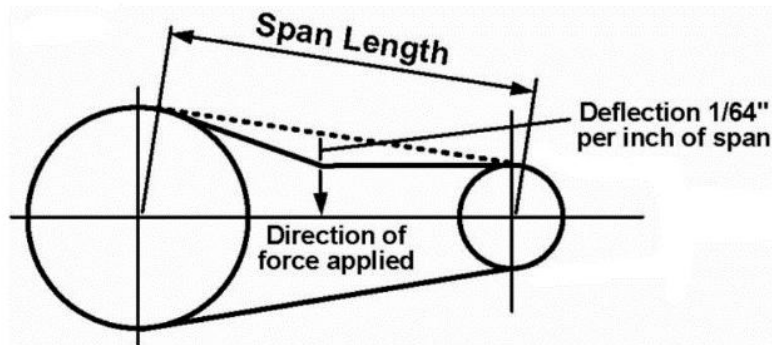

- The top O-ring will have moved up the gauge and show the amount of force used. For example, say 7 pounds.
- Measure the diameter of the smaller pulley. *The diameter of the smaller pulley determines pressure to the belt that should be applied to the belt.*



- Using a deflective force chart, find the value your tension gauge registered and compare it with the diameter of the smaller pulley. *For example, if you are using a BX type belt, your tension gauge registered 10 pounds of force, and the smaller pulley is 5 inches in diameter, then the belt tension is in the acceptable range.*

	Smallest Pulley Diameter Range	RPM Range	Belt Deflection Setting			
			uncogged belts		cogged belts	
			used belt	new belt	used belt	new belt
4L, A, AX	2.0 - 2.9	1000 - 2500	1.8	2.6	2.0	3.0
		2501 - 4000	1.4	2.0	1.6	2.4
	3.0 - 3.6	1000 - 2500	3.6	5.4	4.0	6.0
		2501 - 4000	2.8	4.1	3.3	4.9
	3.8 - 4.8	1000 - 2500	4.4	6.6	4.9	7.3
		2501 - 4000	3.7	5.7	4.3	6.4
5.0 - 7.0	1000 - 2500	5.3	7.8	5.7	9.2	
	2501 - 4000	4.6	6.8	5.1	7.6	
3.4 - 4.2	860 - 2500			4.8	7.2	
	2501 - 4000			4.1	6.2	
5L, B, BX	4.4 - 5.6	860 - 2500	5.2	7.9	7.1	10.5
		2501 - 4000	4.5	6.6	7.1	9.1
5.8 - 8.6	860 - 2500	6.2	9.4	8.4	12.4	
	2501 - 4000	6.0	6.8	7.3	10.7	

If the belt cannot be properly tensioned, install a longer or shorter belt, as necessary.

Fan Pulley and Motor Pulley Alignment

1. For proper belt seating, ensure the centerline of the pulleys are aligned.
2. Use a straight edge to verify pulley alignment.
3. Verify that all pulley setscrews are secure.

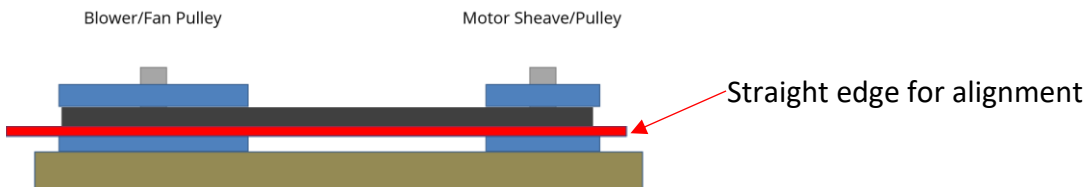

Troubleshooting a Stalled Motor

If motor stalling:

1. Remove the belt and test if the motor still stalls. (Manual mode in the Turntide Technician App.)
2. If motor runs *properly* without the belt:
 - **Slightly reduce the belt tension and test motor operation in small increments or upsize the belt if necessary.**
 - If you installed isolator feet, you may need to increase the belt by 2 sizes.
 - Note however, if the belt is too loose, it will slip and cause reduced airflow, excessive wear, and early failure.
3. If the motor is *still stalling* without a belt:
 - With the motor off, spin the motor by hand to feel bearings or if anything within the motor is clunking around.
 - Verify that power wiring is correctly wired. For example, are P2 & P3 correct or flipped?
 - Using the Turntide Technician App (**General** screen), verify that you have the correct motor model and voltage selected and that it matches the motor nameplate.
 - Confirm there aren't any rub-outs or exposed copper along the motor power wiring (Applicable check only if the motor has been in operation for some time).
 - If the motor continues to stall, contact [Turntide Technical support](#).

Supply and Return Air Sensors

When you install a supply air temperature sensor, it changes the sequence of operations of the motor system in all flows.

1. If the unit is in heating mode and the supply air temperature is greater than 140degF, the Turntide motor will increase speed to increase airflow.
2. If the unit is in cooling mode and the supply air temperature is less than 50degF, the Turntide motor will increase speed to increase airflow.
3. If the sensors are not installed, the motor system maintains its typical control method dictated by the installed flow.
4. Supply and return temperatures are viewable in BOS for connected motors and on the Technician App for all motors.
5. As a failsafe measure, if the supply and return air sensors malfunction, then the motor system maintains the Turntide control method (40/75/90) or any custom setpoints that were installed. A malfunction includes if the Turntide motor controller cannot read any values from the sensor or if the values are invalid.

TURNTIDE TECHNOLOGIES

Turntide Technologies | 11720 Amber Park Drive, Suite 160, Alpharetta, GA 30009 | turntide.com
support@turntide.com

